



# AGRONOMY RESEARCH

# CONTENTS

11

## CORN MANAGEMENT

- 11 [Crop and Fertilizer Management to Overcome Yield Barriers in Continuous Corn\\*](#)
- 16 [Does Corn Seed Orientation in the Furrow Matter?](#)
- 22 [Corn Yield Response to Plant Population in Central and Eastern Ontario](#)
- 24 [Managing Corn for Greater Yield Potential](#)
- 30 [Exploring the Potential for Reduced-Stature Corn](#)

35

## CORN GROWTH AND DEVELOPMENT

- 35 [Pollination in Corn: Timeline of Key Steps](#)
- 38 [Delayed Pollination Effects on "Zipper Ears" in Corn](#)
- 41 [Corn Brace Roots](#)
- 44 [Ear Declination Prior to Corn Maturity](#)
- 46 [Kernel Weight Differences by Hybrid in Iowa](#)

49

## CORN INSECT MANAGEMENT

- 49 [Asiatic Garden Beetle](#)
- 52 [Corn Rootworm Management Using RNAi](#)
- 56 [Field Performance of Vorceed™ Enlist® Corn Rootworm Traits](#)
- 58 [Reduced Corn Rootworm Adult Emergence With RNAi](#)
- 60 [Extended Diapause in Northern Corn Rootworm](#)

62

## CORN DISEASE MANAGEMENT

- 62 [Tar Spot of Corn in the U.S. and Canada](#)
- 70 [Fusarium Crown Rot in Corn](#)
- 72 [Gibberella Ear Rot](#)
- 73 [Fusarium Ear Rot](#)

74

## SOIL FERTILITY AND CORN NUTRIENTS

- 74 [Corn Biomass Sampling Update: Nitrogen Content](#)
- 76 [Corn Biomass Sampling Update: Potassium Content](#)
- 78 [Corn Biomass Sampling Update: Sulfur Content](#)
- 80 [Corn Plant Nutrient Content Ratios Under Moderate and High Yields](#)
- 82 [Corn Response to High pH Soil Environments: Northwestern Kansas, Southwestern Nebraska, and Northeastern Colorado](#)
- 84 [Carbon, Oxygen, and Hydrogen Fertility and Corn Grain Yield](#)
- 86 [Corn Response to Reduced Nitrogen Environments in a 17-Year Study](#)

91

## BIOLOGICALS AND MICROBIALS

91 [Introduction to the Plant Microbiome](#)

97

## WEATHER AND CLIMATE

97 [Is Smoke from Wildfires Affecting Crop Yields?](#)

104 [Impacts of the El Niño Southern Oscillation on Crop Production](#)

110 [High Temperatures Increase Water Stress in Corn](#)

112 [Field Edge Effects in Corn](#)

114 [High Humidity Can Disrupt Pollen Shed in Corn](#)

117

## SOYBEAN MANAGEMENT

117 [Gall Midge in Soybeans](#)

112 [White Mold Management in Soybeans](#)

128 [Red Crown Rot in Soybeans](#)

130 [Soybean Vein Necrosis Virus](#)

132 [Soybean Cyst Nematode Populations Across Northern Iowa](#)

134 [Soybean Seeding Rate Considerations](#)

140 [Herbicide System Effects on Waterhemp Emergence in Soybeans](#)

143

## LIVESTOCK NUTRITION

143 [Plenish® High Oleic Soybeans for On-farm Feeding](#)

145 [Optimum Plant Population for Corn Silage Yield and Quality](#)

146 [Dairy Perspective on Enogen® Feed Corn Hybrids](#)

148 [Beef Perspective on Enogen® Feed Corn Hybrids](#)

150 [Genetic and Environmental Factors Impacting Corn Silage Fiber Digestibility](#)

152

## CANOLA

152 [Blackleg of Canola](#)



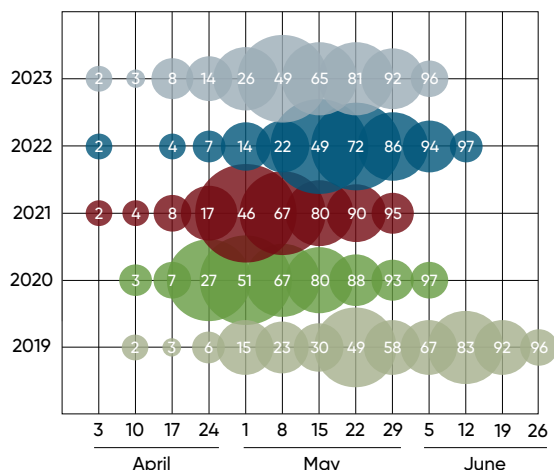
\*Research was supported in part by the Pioneer Crop Management Research Awards (CMRA) Program. This program provides funds for agronomic and precision farming studies by university and USDA cooperators throughout North America. The awards extend for up to four years and address crop management information needs of Pioneer agronomists, sales professionals, and customers.

# INTRODUCTION

## 2023 GROWING SEASON IN REVIEW

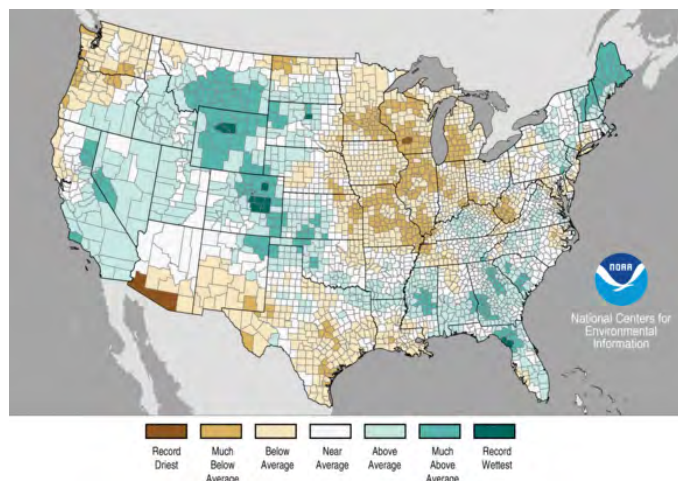
The most remarkable thing about the 2023 growing season is probably just how unremarkable it was, at least compared to the preceding years. At the individual farm level, each growing season has things that make it unique and memorable but 2023 was the first season in several years that was largely free of the widespread weather, supply chain, or trade disruptions that had outsized impacts on previous seasons.

The season got off to a relatively good start in 2023. The pace of corn planting was about average – not quite as early as 2020 and 2021, but without the widespread delays that impacted the 2019 and 2022 seasons (Figure 1).

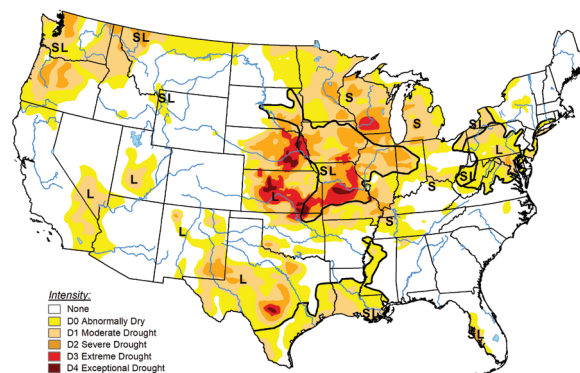


**Figure 1.** U.S. corn planting progress 2019-2023 (USDA-NASS).

As the growing season got underway, it started to become clear that the main factor shaping the 2023 season for many crop producers would be a familiar one – drought stress. The season started with much of the western Corn Belt and Great Plains states already under drought. Below-average rainfall during June in much of the Midwest led to an expansion in drought-affected areas to the east (Figure 2). By July, nearly all of the U.S. Corn Belt was experiencing some degree of drought stress (Figure 3).

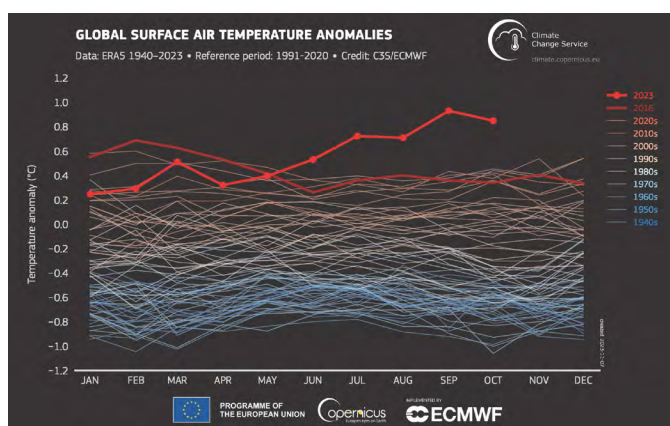


**Figure 2.** Total precipitation percentiles for June 2023 (NOAA).



**Figure 3.** U.S. Drought Monitor map, July 4, 2023 (National Drought Mitigation Center, University of Nebraska-Lincoln).

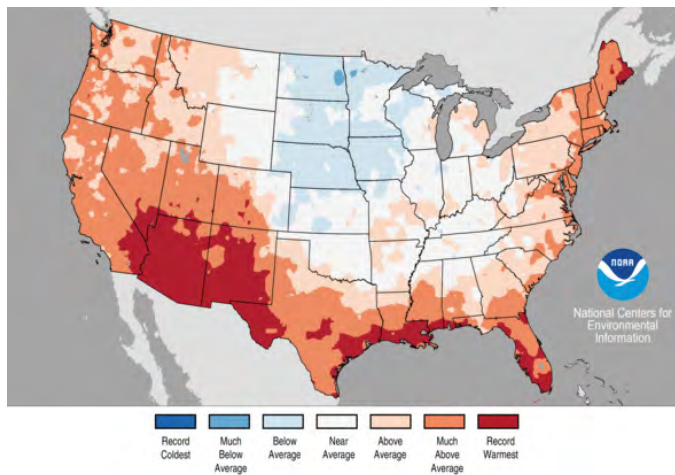
While the summer of 2023 was relatively unremarkable for a lot of the Corn Belt, for much of the rest of the world, it was anything but. Globally, the dominant weather story of 2023 was record-setting temperatures. Summer and fall of 2023 were the hottest in recorded history, and not by a small margin (Figure 4). Many regions around the world experienced extreme heat waves, including much of Southern Europe and Southeast Asia.



**Figure 4.** Monthly global surface air temperature anomalies (°C) relative to 1991-2020 from January 1940 to October 2023, plotted as time series for each year. 2023 and 2016 are shown with thick lines shaded in bright red and dark red, respectively (Copernicus Climate Change Service/ECMWF).

Much of the Southern and Western U.S. also experienced record-setting summer heat (Figure 5). Phoenix, AZ, set a new record with 31 consecutive days exceeding 110° F (43° C). In the Midwest and Great Plains, however, summer temperatures were generally close to normal, which helped to mitigate some of the impact of drought stress on growing crops.

2023 also saw the return of widespread smoke in the atmosphere from wildfires. In 2021, much of the U.S. was impacted by smoke from wildfires burning on the west coast, particularly in California. In 2023, smoke swept down from fires in Canada, which experienced a record-shattering wildfire season (Figure 6). By the end of October, over 45 million acres had been burned, more than 3x that of any previous year and comprising around 5% of the total forested area of Canada.



**Figure 5.** Average temperature percentiles for July 2023 (NOAA).



**Figure 6.** Smoke from Canadian wildfires sweeping down into the upper Midwest; June 14, 2023 (NASA Earth Observatory).

Despite this unprecedented devastation, the impact of smoke in most crop-producing areas was relatively minor. Bouts of smoke cover were often intense but were relatively short-lived and mostly occurred earlier in the summer ahead of critical yield-determining growth stages.

As the season wound down, drought stress remained the dominant factor of 2023. After a very dry June, rainfall remained below average through July and August in many areas. Even for those areas that picked up more rain in the latter portion of the summer, it often was not enough to overcome the existing soil moisture deficit. However, as the crop started coming in, yields often exceeded expectations. In many cases, one or two key rains later in the season were enough to keep the crop going and yields ended up being not too far off of normal or even better than average, despite below average rainfall. Yields tended to be highly variable, as they generally are in drought seasons, but were often not the disaster that growers may have initially feared. For some, the rains came too late to make much of a difference for the 2023 crop, serving only as an impediment to getting it harvested. However, substantial rainfall over much of the Corn Belt during October helped to break some of the drought and get the soil profile in better condition heading into the 2024 season.

Successful crop management under constantly evolving conditions requires smart and efficient use of resources, driven by sound agronomic knowledge. A commitment to improved crop management is a core component of the Pioneer brand, exemplified by our industry-leading network of agronomists across North America. The mission of this team is to help maximize grower productivity by delivering useful insights built on rigorous, innovative research. Pioneer agronomists work to help crop producers manage factors within their control and maximize productivity within the environmental constraints unique to a given growing season, be they favorable or not.

This Agronomy Research Summary is the latest edition of an annual compilation of Pioneer agronomy information and research results. The 2024 edition includes several articles that explore the impacts of weather and climate stresses on crop growth and development. Other highlights include new research on overcoming yield barriers in continuous corn and optimizing soybean seeding rates, as well as updates on several emerging issues in crop production, such as tar spot and fusarium crown rot in corn, and gall midge and red crown rot in soybeans. The summary also looks at the science underlying new innovations in crop production, including an overview of current research on reduced-stature corn, a deep-dive on RNAi technology and how it is being used to protect corn against rootworms, and a review of the rapidly expanding body of research on crop-microbe interactions and how it is being used to develop new biological and microbial products.

<b>Continuous Corn</b>	<b>11</b>
<b>Reduced-Stature Corn</b>	<b>30</b>
<b>RNAi</b>	<b>52</b>
<b>Tar Spot</b>	<b>62</b>
<b>Fusarium Crown Rot</b>	<b>70</b>
<b>Plant Microbiome</b>	<b>91</b>
<b>Wildfire Smoke</b>	<b>97</b>
<b>El Niño</b>	<b>104</b>
<b>Heat and Water Stress</b>	<b>110</b>
<b>Gall Midge</b>	<b>117</b>
<b>Red Crown Rot</b>	<b>128</b>
<b>Soybean Seeding Rate</b>	<b>134</b>

This Agronomy Research Summary provides insights on numerous crop production topics; however, it represents just a small portion of the vast array of resources available in the Pioneer agronomy library at [www.pioneer.com](http://www.pioneer.com). We hope that the resources available in this book and online will help you drive productivity, efficiency, and profitability in 2024.

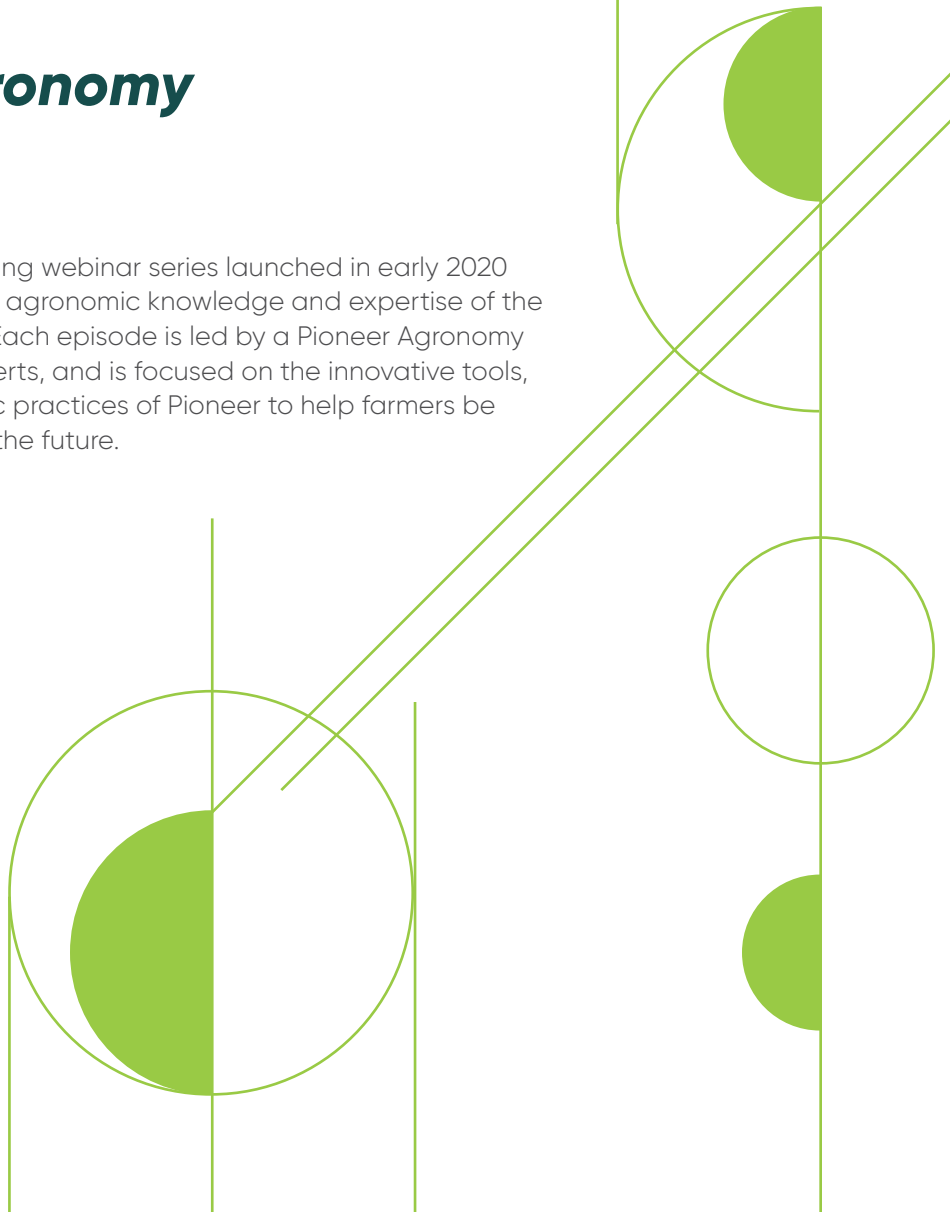
**Mark Jeschke, Ph.D.**  
**Agronomy Manager**



# *Forward –thinking Farming*

*a webinar series  
powered by  
Pioneer® Agronomy*

The Forward-thinking Farming webinar series launched in early 2020 featuring the cutting-edge agronomic knowledge and expertise of the Pioneer® agronomy team. Each episode is led by a Pioneer Agronomy Manager and industry experts, and is focused on the innovative tools, technology, and agronomic practices of Pioneer to help farmers be successful and evolve into the future.





# 2023 Webinar Series

Listen in on the cutting-edge insights of the Pioneer Agronomy team!  
Watch our recent **Forward-thinking Farming** webinars at [pioneer.com/webinars](https://pioneer.com/webinars)

## REVENGE OF THE CYST: SCN CAUSING NEW PROBLEMS

Soybean Cyst Nematode, or SCN, is a pest in almost all soybean growing regions. It may seem like old news, but this boring old pest is showing some resistance to some of our tried-and-true management practices. Join us as we discuss what we're seeing with our field sampling efforts and the best management practices for combating this resistance.

### Speakers:

- o Mike Dillon, *Global Soybean Portfolio leader*
- o Brad Van Kooten, *Marketing Leader for Seed Applied Technologies,*
- o Don Kyle, *Soybean Breeder*
- o Dr. Mary Gumz, *Agronomy Manager*

## TAR SPOT - TAR STOP

Tar Spot has us all checking our blind spot. This newer corn disease, that can wreck up to 30% of your yield, had its first big flair in 2018 and has continued to expand to new geographies over the past two years. Join us as our agronomists share experiences and images from the field and discuss management of the disease, while demonstrating the Pioneer® genetic advantage and how Pioneer corn breeders are innovating a path towards the future for managing this disease.

### Speakers:

- o Ken O'Brien, *Agronomy Sciences Leader*
- o Scott Heuchelin, *Corteva NA Plant Pathology & Global Phytosanitary Lead*
- o Scott Rowntree, *Field Agronomist*
- o Will Tubbs, *Corteva Crop Protection Market Development Specialist*

## KEYS TO UNLOCKING HIGH YIELDING SOYBEANS

Hear from two agronomists, Kyle Holmberg from Tennessee and Matt Vandehaar from Iowa, as they discuss the different management tips that have shown success in unlocking higher soybean yields, both within their geographies as well as across the U.S. Together they will outline four important management practices. From planting guidelines to plant nutrition, our experts in the field map out a path that could drive success in your fields this growing season!

### Speakers:

- o Matt Clover, *Agronomy Manager*
- o Kyle Holmberg, *Field Agronomist*
- o Matt Vandehaar, *Field Agronomist*

## BETTER DAIRY PRODUCTION WITH PLENISH® HIGH OLEIC SOYBEANS

What if dairy farmers could lower feed costs and get higher milkfat from their dairy cows? Enter Pioneer® brand Plenish® high oleic soybeans. With internal and external experts, this webinar, hosted by Dr. Mary Gumz, will examine the science behind how Plenish high oleic soybeans help cows achieve an increase in milkfat – and the economics behind potentially lowered feed costs. See how Plenish has added up to \$1.00 per cow/per day of additional margin for dairy operations – a true win-win for producers!

### Speakers:

- o Dr. Mary Gumz, *Agronomy Manager*
- o Jonathan Rotz, *Field Agronomist*
- o Kevin Putnam, *Field Agronomist*

## U.S. DROUGHT DEBRIEF: WHY WAS IT SO DRY & WILL IT CONTINUE?

Join Pioneer for an in-depth discussion of recent dry conditions across the United States. Dennis Todey from the USDA Climate Hub will discuss the factors that led to a large portion of the United States being drier than normal and what needs to change in the atmosphere to break the cycle of dryness. Dennis will also share an outlook on our weather and what may be in play for the 2024 growing season. Agronomy Manager Matt Essick will share Pioneer exclusive products, tools and information that support farmers rain or shine.

### Speakers:

- o Matt Essick, *Agronomy Manager*
- o Dennis Todey, *Director of the USDA Midwest Climate Hub*



Listen in on the cutting-edge insights of the Pioneer Agronomy team!

Watch our recent **Forward-Thinking Farming** webinars at [pioneer.com/webinars](https://pioneer.com/webinars).

# AGRONOMY TEAM



**Danny Brummel, M.S., Agronomic Resource Manager**

Danny serves as the agronomy science contact for California, Arizona, and the Pacific Northwest. Danny also leads Pioneer's commercial drone fleet and coordinates national on-farm agronomy trials to generate knowledge to develop agronomy innovations for Pioneer. He earned his B.S. and M.S. degrees in Agronomy from Iowa State University and holds CCA and PASp certifications. Danny started his career with Corteva Agriscience in 2019, where he managed disease screening trials and precision phenotyping efforts for crop breeding research.



**Matt Clover, Ph.D., Agronomy Manager**

Matt is responsible for helping guide on-farm trials planning, protocol development, analysis, and communication of trial results. Matt leverages his experience in soil fertility to bolster expertise of the Agronomy Sciences team and support Pioneer agronomists, and sales teams. Matt earned his Ph.D. in soil fertility from Iowa State University and his M.S. and B.S. degrees from the University of Illinois in Crop Sciences. He is a Certified Professional Soil Scientist (CPSSc). Matt came to Pioneer in April 2017 after a nine-year career in the fertilizer industry with various roles in agronomy, and research and development.



**Chism Craig, Ph.D., Agronomy Manager - MidSouth**

Chism Craig is the Agronomy Leader for the North Delta region of the Coastal commercial unit and is a seasoned agriculture professional with over 20 years of experience in the industry. Growing up on a diversified row crop farm in Friars Point, MS, Chism was exposed to the agriculture industry at an early age and was active in his family's crop consulting and research businesses. He holds a B.S. in Agricultural Pest Management from Mississippi State University, an M.S. in Entomology from Mississippi State University, and a Ph.D. in Crop Physiology and Agronomy from Louisiana State University.



**Matt Essick, M.S., Agronomy Manager**

Matt is from a small community in northwest Iowa and earned his B.S. in Agricultural Business and M.S. in Agronomy from Iowa State University. Matt joined Pioneer as a Management Assistant working at the Cherokee, Iowa, soybean production plant. He transitioned to a Pioneer Sales Representative where he gained hands-on experience in both sales and agronomy before becoming a Territory Manager for Pioneer. Matt transitioned to an Area Agronomist and then to a Product Agronomist before joining the Agronomy Sciences Team. Matt is responsible for the Western U.S.



**Grant Groene, M.S., Global Seed Agronomy Lead**

Grant has been with the Corteva organization since 2010 where he began as a Field Agronomist in Eastern Kansas. He spent the next several years working as a Territory Manager and Product Lifecycle Manager, supporting teams in Texas and across the High Plains. Grant relocated to Iowa and began leading the Global Agronomy efforts in 2018. His primary responsibility is to plan strategic agronomy initiatives, facilitate agronomy trainings, and share best agronomic practices with colleagues across the global Corteva business. Grant graduated from Kansas State University with B.S. in Agronomy and an M.S. in Crop Physiology and Plant Breeding, and holds an M.B.A. from West Texas A&M.



**Mary Gumz, Ph.D., Agronomy Manager**

Mary is a native of northern Wisconsin and earned her B.S. in Agronomy from the University of Minnesota – Twin Cities and M.S. and Ph.D. in Weed Science from Purdue University. After working in the crop protection and seed industries as a Technical Service Agronomist, she joined Pioneer in 2008 as an Area Agronomist and later became Product Agronomist for northwest Indiana. She is now the Agronomy Manager for the Eastern U.S.





**Mark Jeschke, Ph.D., Agronomy Manager**

Mark earned his B.S. and M.S. degrees in Crop Sciences at the University of Illinois at Urbana-Champaign and Ph.D. in Agronomy at the University of Wisconsin-Madison. Mark joined Pioneer in 2007 and currently serves as Agronomy Manager. His primary role is development and delivery of useful and timely agronomy information based on Pioneer and university agronomy research. Mark authors and edits many of the agronomy resources available in the Pioneer agronomy library. Mark is originally from northern Illinois and is actively involved in the family corn and soybean farm near Rock City, Illinois.



**Luke Northway, Agronomy Systems Manager**

Luke double majored in Management Information Systems and Agricultural Business at Iowa State University and received his MBA from the University of Iowa. He started with Pioneer in 2007 as a support person for FIS and Pioneer® FIT Mapping System. He now works on the Agronomy Sciences team as Product Owner of Performance Explorer, Trials Planning, and mobile Trials Data Entry.



**Ken O'Brien, M.S., Agronomy Science Leader**

Ken serves as the Agronomy Sciences Leader for Corteva's U.S. seed businesses. In his 16+ years with the organization he has held various roles in sales and marketing leadership across both seed and digital/software product lines. His current role supports the field agronomy teams for our seed businesses to provide them with the systems, processes, and information they need in order to provide our customers with successful crop management and product placement information. Ken holds B.S. degrees in Agronomy and Plant Health & Protection from Iowa State University and M.S. in Agronomy from Iowa State University.



**Todd Rowe, M.S., Agronomy Manager- Southeast**

Todd is a native of eastern North Carolina and earned his B.S. in Agronomy from North Carolina State University and M.S. in Seed Technology and Business from Iowa State University. Todd held Agronomist positions with other companies prior to joining Pioneer in 2010 as Area IMPACT Lead at the Kinston, North Carolina Research Station. He is now the Agronomy Leader for the Southeast sales area.



**Jonathan Siebert, Ph.D., Agronomy Manager - MidSouth/Southwest**

Jonathan is a native of Eunice, Louisiana and earned his B.S. degree in Agronomy, M.S. degree in Weed Science, and Ph.D. in Plant Physiology with a minor in Entomology from Louisiana State University. Jonathan joined Corteva in 2010 and has held multiple roles including Crop Protection R&D Field Scientist, PhytoGen Field Station Operations Lead, Enlist Field Sales Leader, Customer Technical Specialist, Cotton Development Specialist and most recently Agronomy Leader for the South Delta (MidSouth) and Southwest.



**April Battani, Senior Graphic Designer**

April earned both a B.A. in Graphic Design and a B.A. in Creative Advertising from Drake University in Des Moines, Iowa. She started with Pioneer in 2012 as a Publishing Assistant for Agronomy Sciences. She currently works as a Senior Graphic Designer for the Creative Services team supporting Agronomy Sciences. Her role includes the design, publication, and project management of web-based and printed materials, including the Agronomy Sciences Research Summary books produced annually. In addition, April provides individually tailored illustrations and charts for internal sales, marketing, and research clients.



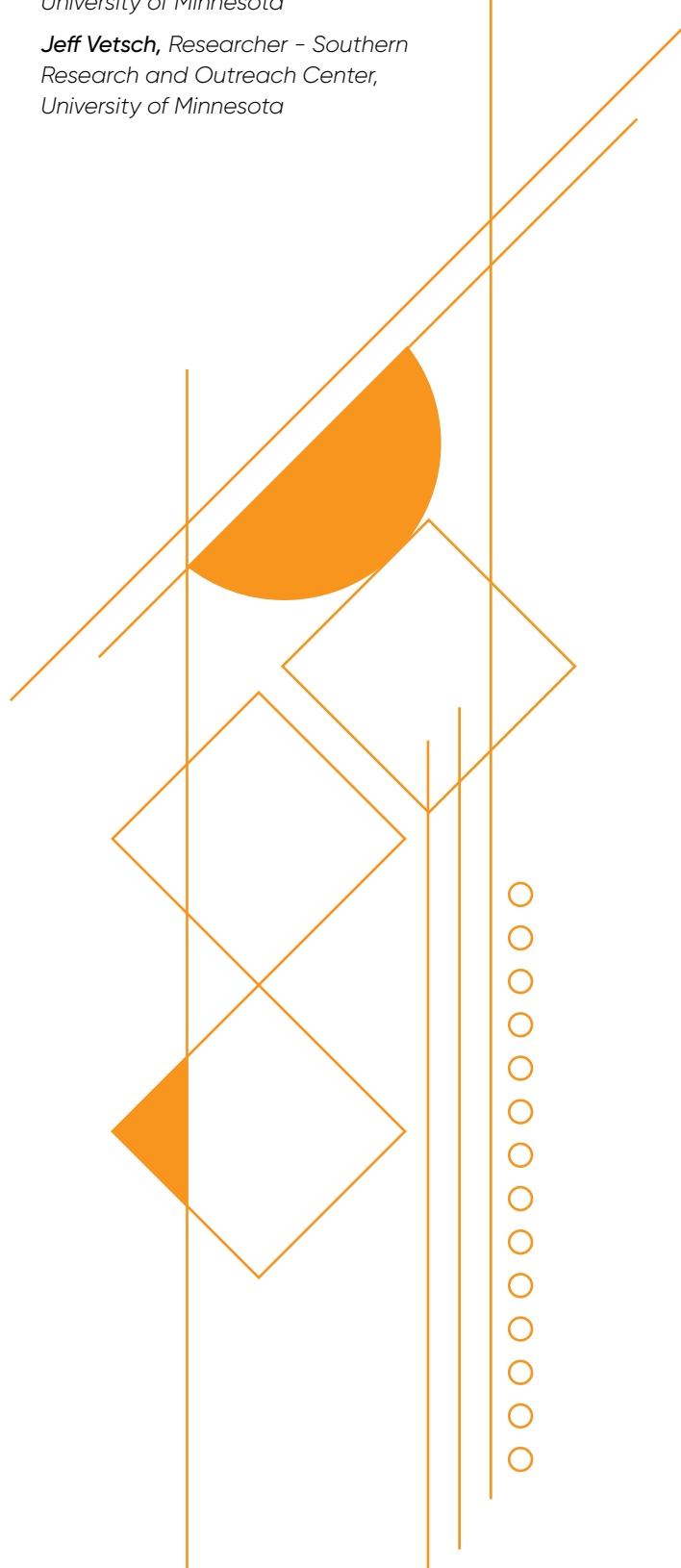
# AUTHORS

## CORTEVA AGRISCIENCE AUTHORS

- Jake Bates, Pioneer Product Agronomist*
- Jim Bing, Ph.D., Program Leader, Insect Control Traits*
- Dann Bolinger, Dairy Specialist*
- Lucas Borrás, Ph.D., Research Scientist*
- James D'Aoust, Pioneer Sales Agronomist*
- Troy Deutmeyer, Pioneer Field Agronomist*
- Maggie Durnin, Pioneer Intern*
- Kurt Eischeid, Pioneer Field Agronomist*
- Cale Gent, Pioneer Sales Consultant*
- Robert Gunzenhauser, Research Scientist*
- Kristin Hacault, Agronomy Information Consultant*
- Nick Hanson, Pioneer Associate Seller*
- Paul Hermans, Pioneer Sales Agronomist*
- Dennis Holland, Pioneer Product Agronomist*
- Dalton Kampsen, Former Pioneer Field Agronomist*
- Jason Kienast, Pioneer Sales Representative*
- Jeff Klever, Staff Associate Investigator*
- Mike Kriegshauser, Pioneer Strategic Account Manager*
- Nate LeVan, Pioneer Field Agronomist*
- Nelson Lobos, Ph.D., Senior Nutritionist*
- Bill Long, Pioneer Field Agronomist*
- Tim Mabry, Field Scientist*
- Bill Mahanna, Ph.D., Global Nutritional Sciences Manager*
- Matt McKenzie, Pioneer Field Agronomist*
- Tim Nowatzki, Ph.D., Senior Research Scientist*
- Chris Olbach, Pioneer Area Agronomist*
- Nate Pech, Pioneer Field Sales Agronomist*
- Chris Phipps, Pioneer Territory Manager*
- Stephen Strachan, Ph.D., Research Agronomist*
- Cody Sullivan, Pioneer Territory Manager*
- Aaron Vammer, Pioneer Field Agronomist*
- Matt Vandehaar, Pioneer Field Agronomist*
- Ryan Van Roekel, Ph.D., Former Pioneer Field Agronomist*
- Alex Woodall, Pioneer Field Agronomist*

## UNIVERSITY AUTHORS

- Jeff Coulter, Ph.D., Professor and Extension Agronomist, University of Minnesota*
- Jeff Vetsch, Researcher - Southern Research and Outreach Center, University of Minnesota*

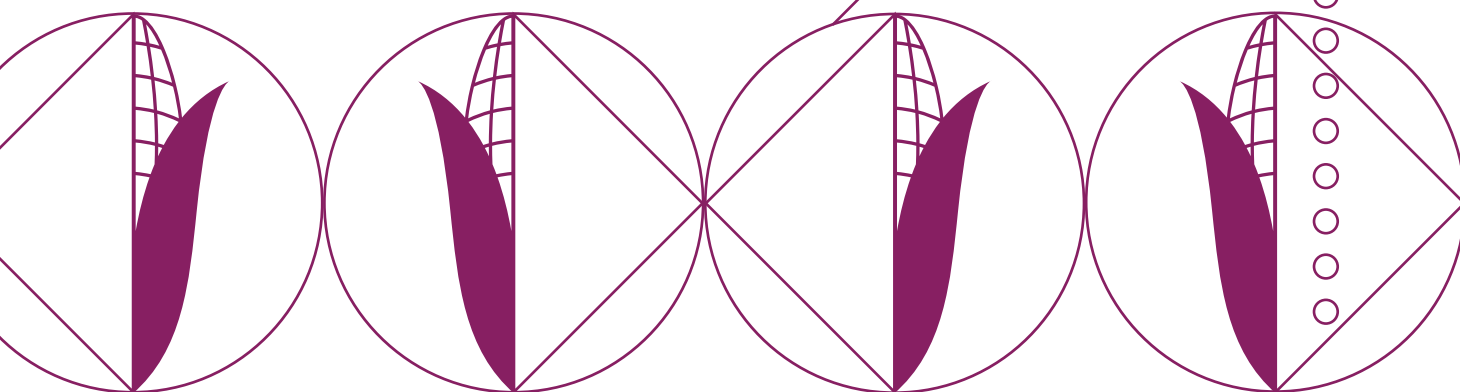


# Crop and Fertilizer Management to Overcome Yield Barriers in Continuous Corn

*Jeff Coulter, Ph.D., Professor and Extension Agronomist and  
Jeff Vetsch, Researcher - Southern Research and Outreach Center*

*University of Minnesota*

- A two-year field study was conducted by Dr. Jeff Coulter and Jeff Vetsch of the University of Minnesota to identify management practices that increase yield, nitrogen use efficiency, and profitability in continuous corn.
- The study compared standard and advanced fertilizer management systems, each within normal and intensive agronomic management systems in southern Minnesota.
  - » The advanced fertilization program included phosphorous (P) and potassium (K) application based on grain removal and soil-test levels, surface banded starter fertilizers, a greater total nitrogen (N) rate, and two in-season N applications.
  - » The intensive agronomic system included partial removal of the corn stover in the fall after grain harvest, planting a longer-season corn hybrid at a higher planting rate, and applying foliar fungicide at tasseling.
- Compared to the standard fertility program, the advanced fertilization program increased yield in both years and partial net return in one year. This was consistent in both agronomic management systems.
- The intensive agronomic system was advantageous to yield and profitability in both years.



## INCREASING CORN YIELD AND EFFICIENCY

Potential corn yield is that of a hybrid when grown in a suitable environment with optimal management in the absence of stresses from nutrients, water, and pests. Past high-yield research has focused on grain yield as the primary indicator of performance; however, fertilizer use efficiency is also important for economic and environmental viability.



Advanced fertilizer management ensures that supplies of all nutrients are adequate to meet the demands of the crop throughout the entire growing season, and achieves high fertilizer use efficiency through optimization of fertilizer source, rate, time, and placement. Nitrogen is often the most limiting nutrient for corn production and is frequently applied in excess and far in advance of rapid corn uptake. This leads to low corn recovery of applied N and an increased risk of N loss, which carries environmental and economic consequences. Enhanced synchrony of N application timing and rate with corn requirements is key to enhancing corn uptake of applied N, thereby improving yield and reducing N loss.

## RESEARCH OBJECTIVES

A two-year field study was conducted by Dr. Jeff Coulter and Jeff Vetsch of the University of Minnesota as part of the Pioneer Crop Management Research Award program. The goal of this study was to identify and better understand agronomic practices that increase corn yield and reduce risk of N loss, thereby enhancing profitability. This was evaluated in continuous corn, which requires more intensive management for high yield and has a greater risk of N loss compared to a corn-soybean rotation.

### Objectives

1. Determine the corn yield levels attainable with intensive management.
2. Compare the performance of advanced fertilizer management and intensive agronomic management systems to those with standard practices in line with university guidelines.
3. Assess whether university fertilizer guidelines can attain yields at levels close to yield potential.

## RESEARCH METHODS

This project compared two agronomic systems:

1. Normal – Standard farmer practices.
2. Intensive – A high-yield system.

For both systems, standard fertilizer management in line with university guidelines was compared to advanced fertilizer management. Within these four main plot treatments, split plots were with and without N fertilizer for evaluation of N use efficiency parameters.

### Advanced Fertilization

- P and K application based on grain removal and soil-test levels
- Surface-banded starter fertilizer
- Two in-season N applications and a greater total N rate

### Intensive Agronomics

- Longer-season hybrid
- Higher planting rate
- Partial removal of corn stover
- Foliar fungicide

Field experiments were conducted at Waseca, MN, in 2019 and 2020 on rainfed tile-drained Nicollet clay loam soil. Treatments were applied to the same plots each year.

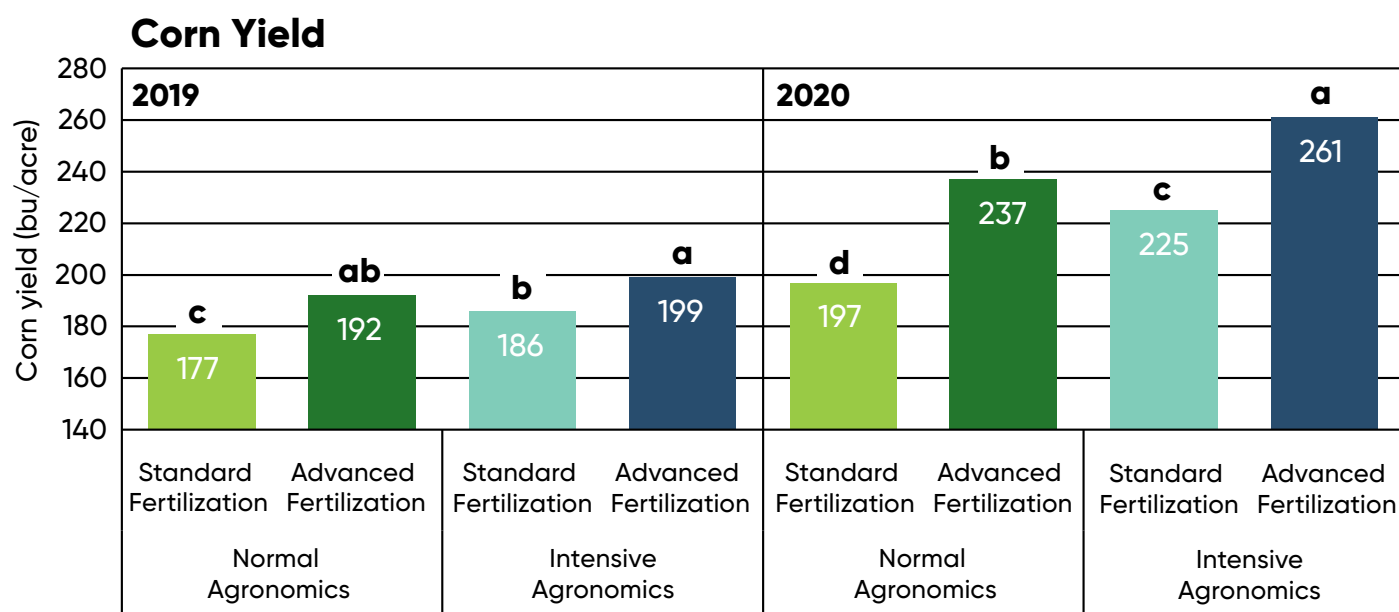
Compared to normal agronomics, the intensive agronomics treatment included partial removal of corn stover after harvest, planting a longer-season corn hybrid at a higher planting rate and applying foliar fungicide at tasseling. The advanced fertilization treatment included P and K application based on grain removal and soil-test levels, surface-banded starter fertilizers, a greater total N rate, and two in-season N applications. Complete treatment details are listed in Table 1.

Treatments were replicated four times in plots that were eight rows wide by 50 feet long. Corn was planted in 30-inch rows in early May in both years. Final corn populations were 34,000 and 39,000 plants/acre for the normal and intensive agronomic treatments, respectively. Weeds were controlled using pre- and post-emergence herbicides. All fertility treatments included a broadcast sulfur application of 25 lbs/acre S and an in-furrow starter fertilizer (10-34-0) of 5 lbs N and 16 lbs P<sub>2</sub>O<sub>5</sub>/acre.

Residue management and tillage practices for all treatments included shredding of stalks at harvest, fall tillage with a disk ripper, and a spring tillage pass with a field cultivator. Plots were harvested at physiological maturity to determine grain yield and moisture content. Agronomic N use efficiency was calculated as: (grain yield in the treatment with N fertilization – grain yield in the corresponding treatment without N fertilization) / (N fertilizer rate in the treatment with N fertilization – N fertilizer rate in the corresponding treatment without N fertilization).

**Table 1.** Agronomic and fertilizer management components of the treatments at Waseca, MN, 2019 to 2020.

Agronomic Management	Normal		Intensive	
Fertilizer Management	Standard	Advanced	Standard	Advanced
Corn stover harvested in fall	0%	0%	40%	40%
Corn hybrid maturity	101 CRM	101 CRM	105 CRM	105 CRM
Planting rate (seeds/acre)	36,000	36,000	41,000	41,000
Foliar-applied fungicide at VT	No	No	Aproach® Prima	Aproach® Prima
S fertilization	20 lb/acre S (gypsum)	20 lb/acre S (gypsum)	20 lb/acre S (gypsum)	20 lb/acre S (gypsum)
P fertilization strategy	U of M guidelines	50% of grain removal	U of M guidelines	50% of grain removal
K fertilization strategy	U of M guidelines	100% of grain removal	U of M guidelines	100% of grain removal
Broadcast P <sub>2</sub> O <sub>5</sub> + K <sub>2</sub> O (lb/acre)	0 + 30	43 + 69	0 + 30	43 + 69
Total lb N/acre	180	220	180	220
10-34-0 in seed furrow at planting	5 lb N/acre + 16 lb P <sub>2</sub> O <sub>5</sub> /acre	5 lb N/acre + 16 lb P <sub>2</sub> O <sub>5</sub> /acre	5 lb N/acre + 16 lb P <sub>2</sub> O <sub>5</sub> /acre	5 lb N/acre + 16 lb P <sub>2</sub> O <sub>5</sub> /acre
12-0-0-26 surface-banded (2 inch x 0 inch) at planting	0	3 lb N/acre + 5.8 lb sulfate-S/acre	0	3 lb N/acre + 5.8 lb sulfate-S/acre
28-0-0 surface-banded at planting	0	21 lb N/acre	0	21 lb N/acre
Pre-plant urea (lb N/acre)	175	111	175	111
Injected 28-0-0 at V6 (lb N/acre)	0	40	0	40
28-0-0 surface-banded near rows at V14 (lb N/acre)	0	40	0	40



**Figure 1.** Corn yield response to agronomic and fertilizer management treatments at Waseca, MN. Within a site-year, values with the same letter are not different at P ≤ 0.05.

## GROWING CONDITIONS

In both years, there was adequate rainfall for corn growth throughout the growing season. Monthly average air temperature in May, June, and August was relatively cool in 2019. This contributed to lower grain yields in 2019. In comparison to 2019, rainfall during 2020 was relatively low during April and September, but it was adequate for corn growth and was evenly distributed May through August.

Compared to 2019, average monthly air temperature was similar in 2020, except for June and July, which were warmer, and September, which was cooler. Collectively, these weather conditions in 2020 resulted in excellent kernel set and a prolonged grain-filling period, which led to very high grain yield (average = 261 bu/acre for the treatment with advanced fertilizer management plus intensive agronomic management).

## RESULTS

Averaged across the treatments, corn grain yield was 189 and 230 bu/acre in 2019 and 2020, respectively (Figure 1). Lower grain yield in 2019 is attributed to green snap (about 5% of plants in the normal agronomics treatment and about 6%–10% of plants in the intensive agronomics treatment), a cool and wet May that slowed early vegetative growth, and wet conditions due to above-normal rainfall throughout the growing season following a wet fall in the previous year.

In 2019, grain yield was greatest with advanced fertilizer management and either normal or intensive agronomics (average = 196 bu/acre). The yield of these treatments averaged 8% greater than that with standard fertilizer management. However, in 2020, advanced fertilizer management plus in-

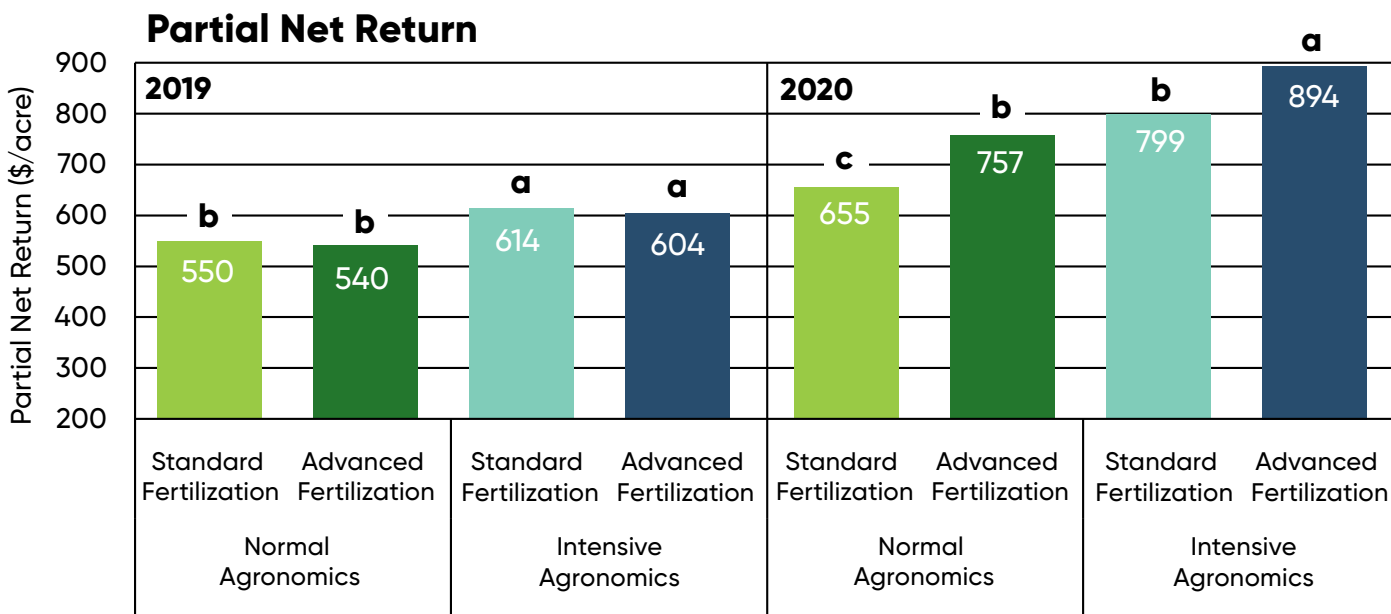
tensive agronomics produced the highest grain yield (261 bu/acre), which was 10% higher than that with advanced fertilizer management plus normal agronomics. In 2020, compared to standard fertilizer management, grain yield with advanced fertilizer management was 20% greater under normal agronomics and 16% greater under intensive agronomics.

In 2019, kernel weight was not significantly different among treatments, while the greatest kernel number occurred with advanced fertilizer management and either level of agronomic management, or with standard fertilizer management plus intensive agronomics (Table 2). In 2020, there was a similar pattern in grain yield and kernel number among the treatments, as the highest values occurred with advanced fertilizer management plus intensive agronomics and the lowest values occurred with standard fertilizer management plus normal agronomics (Table 3).

Kernel weight in 2020 was greater with advanced compared to standard fertilizer management for both levels of agronomics. Across both study years, increased kernel number consistently boosted grain yield, while heavier kernels were associated with greater grain yield in only the highest-yielding year of 2020, where the maximum yield was 261 bu/acre (compared to 2019 where the maximum yield was 199 bu/acre).

## CONCLUSIONS

Grain yield was greater with advanced compared to standard fertilizer management. When advanced fertilizer management was used, grain yield was not greater with intensive agronomics (i.e., partial stover harvest, longer-season hybrid, higher planting rate, and foliar fungicide) in 2019, but it was in 2020.



**Figure 2.** Partial net return for agronomic and fertilizer management treatments at Waseca, MN. Partial net return includes only those field operation and input costs, and revenues that varied among treatments. Within a site-year, values with the same letter are not different at  $P \leq 0.05$ .

Fertilizer and field operation costs at Waseca were \$71.58/acre greater with advanced fertilizer management compared to standard fertilizer management. When intensive agronomic management was used, the increase in grain yield with advanced fertilizer management compared to standard fertilizer management in 2019 (average = 14 bu/acre) was not enough to offset the increased treatment cost. Therefore, the greatest net economic return in 2019 at Waseca occurred with standard fertilizer management plus intensive agronomics. However, net return with advanced fertilizer management plus intensive agronomics was only \$9.97/acre less than that with standard fertilizer management applied to intensive agronomics in 2019.

The exceptionally favorable growing conditions in 2020 resulted in high grain yield and relatively low grain moisture at harvest. Under these conditions, grain yield and net economic return were greatest with advanced fertilizer management plus intensive agronomics.

Advanced fertilizer management plus normal agronomics produced the second-highest grain yield but third highest net economic return in 2020, while standard fertilizer management plus intensive agronomics produced the third-highest grain yield but second-highest net economic return in 2020. This was due to greater treatment cost for advanced compared to standard fertilizer management (\$71.58/acre) than for intensive agronomics compared to normal agronomics (\$32.50/acre).

Averaged across both years, partial net economic return was greatest with advanced fertilization plus intensive agronomics (\$749.00/acre). This value was \$21.34/acre greater than that with standard fertilization plus intensive agronomics, \$47.66/acre greater than that with advanced fertilization plus normal agronomics and \$72.41/acre greater than that with standard fertilization plus normal agronomics.

**Table 2.** Corn agronomic and economic responses to agronomic and fertilizer management treatments at Waseca, MN, in 2019.

Agronomic Management	Normal		Intensive		
	Fertilizer Management	Standard	Advanced	Standard	Advanced
Grain yield (bu/acre at 15%)		177 c <sup>a</sup>	192 ab	186 b	199 a
Kernel weight (milligrams/kernel)		255 a	265 a	251 a	262 a
Kernel number (kernels/m <sup>2</sup> )		3,469 b	3,621 ab	3,703 a	3,796 a
Agronomic N use efficiency <sup>b</sup>		0.64 ab	0.60 b	0.69 a	0.65 ab
Grain moisture at harvest (%)		19.3 b	19.6 b	20.4 a	19.7 ab
Partial net return (\$/acre) <sup>c</sup>		549.95 b	540.38 b	613.69 a	603.72 a
Revenue from grain at \$4.50/bu (\$/acre)		796.50	864.00	837.00	895.50
Revenue from stover, after costs (\$/acre) <sup>d</sup>		-	-	66.69	66.69
Cost of drying grain (\$/acre) <sup>e</sup>		34.25	39.74	45.20	42.09
Total cost of treatment (\$/acre) - seed, fert., and fung. <sup>f</sup>		212.30	283.88	244.80	316.38

**Table 3.** Corn agronomic and economic responses to agronomic and fertilizer management treatments at Waseca, MN, in 2020.

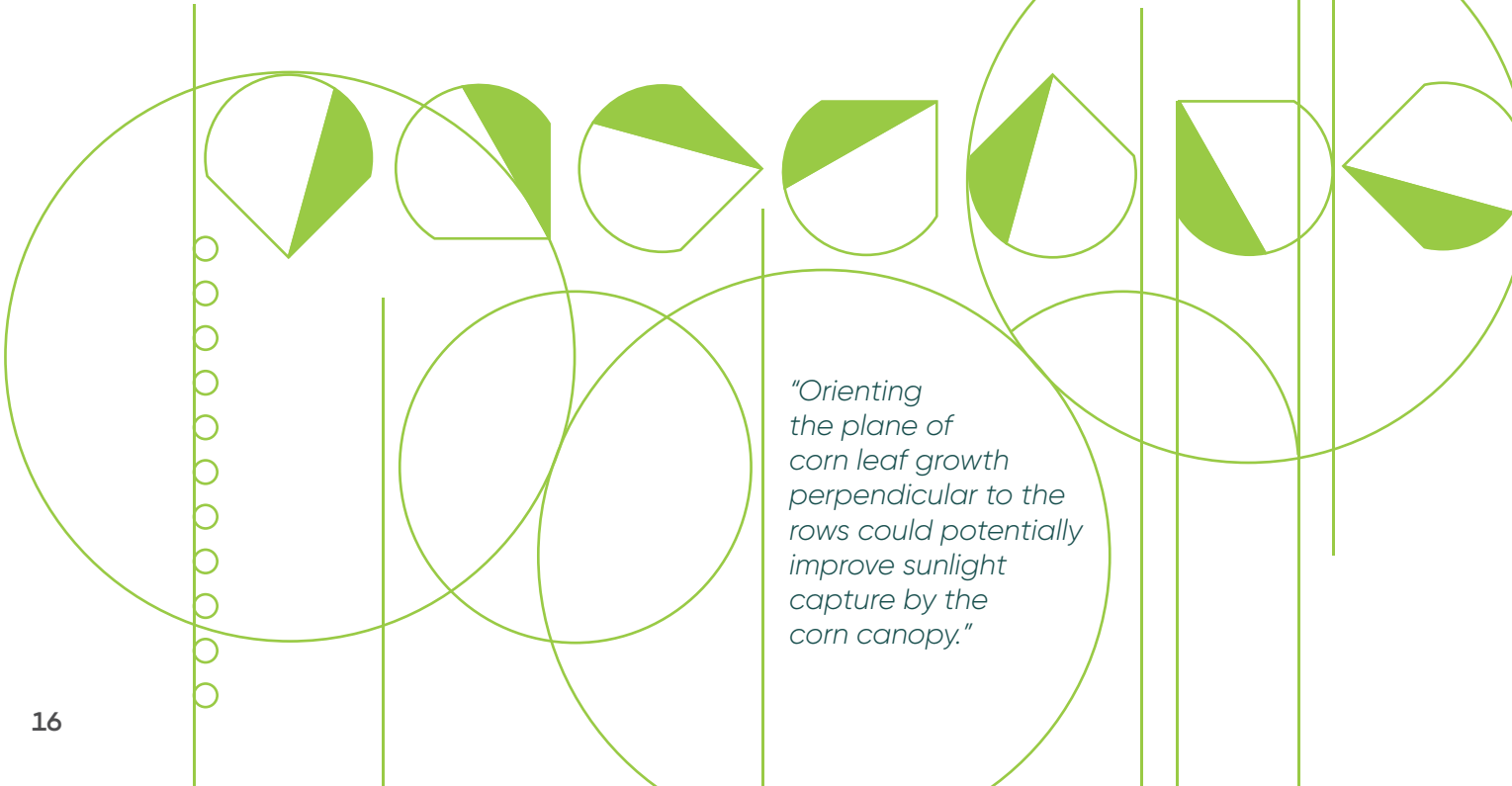
Agronomic Management	Normal		Intensive		
	Fertilizer Management	Standard	Advanced	Standard	Advanced
Grain yield (bu/acre at 15%)		197 d <sup>a</sup>	237 b	225 c	261 a
Kernel weight (milligrams/kernel)		281 b	303 a	268 b	286 ab
Kernel number (kernels/m <sup>2</sup> )		3,501 c	3,913 b	4,190 b	4,560 a
Agronomic N use efficiency <sup>b</sup>		0.69 c	0.78 b	0.87 a	0.87 a
Grain moisture at harvest (%)		17.2 b	17.4 b	18.5 a	17.6 b
Partial net return (\$/acre) <sup>c</sup>		654.70 c	757.02 b	798.95 b	894.27 a
Revenue from grain at \$4.50/bu (\$/acre)		886.50	1,066.50	1,012.50	1,174.50
Revenue from stover, after costs (\$/acre) <sup>d</sup>		-	-	66.69	66.69
Cost of drying grain (\$/acre) <sup>e</sup>		19.50	25.60	35.44	30.54
Total cost of treatment (\$/acre) - seed, fert., and fung. <sup>f</sup>		212.30	283.88	244.80	316.38

<sup>a</sup>Within a row, values followed by the same letter are not different at  $P \leq 0.05$ . <sup>b</sup>Bushels gained per pound of N applied, compared to the non-fertilized control. <sup>c</sup>Includes only those field operation and input costs, and revenues that varied among treatments. <sup>d</sup>Assumes 2.7 large round bales harvested/acre in both sustainable intensification treatments and sold at \$35.00/bale, \$7.15/acre for raking, \$13.10/acre for baling, and \$2.80/bale for moving. <sup>e</sup>Assumes a drying cost of \$0.045/pound/bu. <sup>f</sup>Includes only those field operation and input costs that varied among treatments.

# Does Corn Seed Orientation in the Furrow Matter?

Mark Jeschke, Ph.D., Agronomy Manager

- Agronomists and corn producers have long been interested in the potential for controlling the orientation of planted corn seeds in the furrow as a way to optimize early root and shoot growth and the orientation of the plant's leaves.
- When a corn kernel is planted with the tip pointed downward, the emerging radicle and coleoptile are pointed in the correct direction for growth.
- The plane of corn leaf growth tends to correspond to the direction of the germ of the planted seed, so seed orientation can be used to influence leaf orientation of plants.
- Several Pioneer and university studies over the years have examined the effects of seed orientation on corn growth and yield, but results have been mixed.
- Studies have demonstrated the ability of controlled seed orientation to influence corn emergence and canopy architecture in ways that could benefit yield performance.
- The amount and consistency of yield gains that can be achieved are not clear however, given the limited number of studies and mixed results that they have produced.



*"Orienting the plane of corn leaf growth perpendicular to the rows could potentially improve sunlight capture by the corn canopy."*



## INTEREST IN SEED ORIENTATION EFFECTS

Agronomists and corn producers have long been interested in the potential to improve corn growth and yield by controlling the orientation of the corn seed in the furrow at planting, with research on this question dating back to at least the 1950s (Peters and Woolley, 1959). The goal of this research has been to determine if controlling the orientation of planted seeds can help optimize early root and shoot growth and the orientation of the plant's leaves.

Despite ongoing interest in the potential value of uniform seed orientation, the total body of research on the topic remains relatively sparse and results over the years have been mixed. The need to precisely control the orientation of each seed and the lack of a mechanized means to do so has meant that research on this topic has gener-



ally been difficult and labor-intensive. The lack of any commercially available planter technology capable of controlling seed orientation has likely also limited the degree of urgency in researching seed orientation – even if it were shown to matter, growers would have no way of doing anything about it.

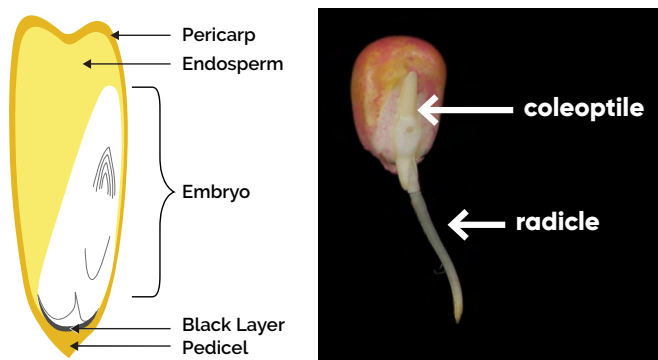
The potential value of corn seed orientation remains a subject of interest today for a couple of key reasons. First, although there is not yet a planter unit on the market capable of controlling corn seed orientation, planter technology overall has advanced considerably over the past few decades. With the

development of planting technologies such as John Deere ExactEmerge™ and Precision Planting SpeedTube® that maintain control of the seed from the meter until it is deposited in the furrow, manipulating seed orientation seems like much less of a leap in technology than it would have been 60 years ago when the first research into the question was being conducted. Second, changes in agronomic practices such as higher plant densities and earlier planting could make any advantages in emergence uniformity or crop canopy structure attainable through uniform seed orientation more important than they might have been in the past.

## IMPACTS ON CORN GROWTH

### Germination and Emergence

The reason that corn seed orientation could potentially influence corn growth and yield has to do with how the initial growth from the germinating seed occurs. The radicle root emerges near the tip of the kernel and the coleoptile emerges from the embryo side of the kernel and elongates in the opposite direction toward the dent end of the kernel (Figure 1).



**Figure 1.** Diagram of a corn kernel showing components of the embryo and a germinated corn seed showing the emerging coleoptile and radicle. Seedling photo provided courtesy of Iowa State University.

When a corn kernel planted with the tip pointed downward, the emerging radicle and coleoptile are pointed in the direction they need to grow, without the need for the seedling to expend additional energy and time to bend their growth downward and upward, respectively (Figure 2). Corn seeds planted uniformly with the kernel tips pointed downward could potentially lead to quicker and more uniform emergence.



**Figure 2.** Corn seedling that was planted with the kernel tip angled upward, showing how both the coleoptile and radicle had to bend as they elongated to grow in the proper direction. Photo courtesy of Iowa State University.

### Leaf Orientation

The orientation of the corn seed in the furrow can also influence the orientation of the plant's leaves. Corn is a distichous plant, meaning that its leaves are arranged alternately on opposite sides of the stem, with the total leaf area of the plant contained largely within the same vertical plane. The standard practice of planting corn in rows – most commonly spaced 30 inches (76 cm) apart in North American corn production – means that a plant will be in much closer proximity to its neighbors within the row than to plants in adjacent rows. Preferentially orienting the plane of corn leaf growth perpendicular to the rows, so that leaves extend into the interrow space could potentially improve sunlight capture by the corn canopy and reduce plant-to-plant competition for space and light within the row.

The orientation of the embryo (germ) side of the corn seed in the furrow has been shown to influence the orientation of the plant's leaf growth (Fortin and Pierce, 1996). The plane of leaf growth tends to correspond to the direction of the germ. Consequently, seeds planted with the germ side perpendicular to the row will tend to have leaves oriented across the row rather than toward adjacent plants in the row (Figure 3).



**Figure 3.** Corn plants in a Pioneer field experiment showing contrasting leaf orientation resulting from seeds planted tip down with the germ oriented with the row (left) and perpendicular to the row (right) (Paszkiwicz et al., 2005).

While this would seem to constitute a considerable advantage attainable through controlled seed orientation, the situation is complicated somewhat due to the inherent adaptability of corn plants during vegetative growth. Even though the orientation of the germ has a large impact on determining the orientation of the leaves, the plane of leaf growth is not completely fixed throughout the plant's development. Research has shown that corn plants have some capacity to adjust their leaf orientation in response to their neighbors and redirect leaf growth toward the interrow space (Maddonna et al., 2002). A Pioneer field study found that this adjustment in leaf orientation occurs relatively early in the plant's development – prior to the V6 growth stage (Jeschke and Uppena, 2015).

Maddonna et al. (2002) showed that adaptive ability can vary by hybrid. Of the two hybrids included in their study, one showed an increased proportion of leaves oriented toward the interrow and one did not. The extent to which this adaptive capacity varies among modern commercial hybrids is not known. Consequently, the amount and consistency of additional benefit to leaf orientation attainable through controlled seed orientation is not clear.

## SEED ORIENTATION RESEARCH

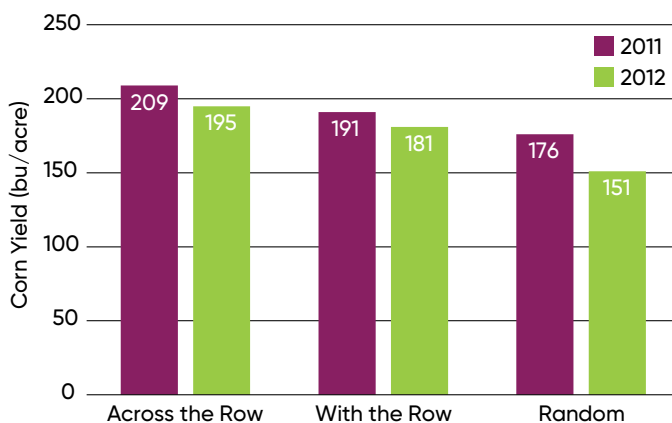
Several studies over the years have examined the effect of seed orientation on corn growth and yield. These studies have varied in the specific seed orientations tested, the methods employed in achieving desired orientations, additional factors included in the studies, and the outcomes that were measured.

### University Research

**Ohio State University (1967-1968)** – One of the earliest studies on corn seed orientation was conducted in the 1960s at Ohio State University (Patten and Van Doren, 1970). This study compared seeds planted tip-down vs. tip-up but did not control for the orientation of the germ. Results showed that seeds planted tip-down achieved earlier and more complete emergence with more rapid seedling growth and were better able to overcome stressful conditions during germination and emergence. However, despite favorable effects on emergence and early growth, seed orientation did not ultimately have a significant effect on yield.

**Illinois State University (2011-2012)** – A two-year study conducted by Illinois State University, partially supported through the Pioneer Crop Management Research Awards program, compared yield of corn planted tip-down with the germ oriented with the row, tip-down with the germ oriented across the row, and randomly (Walk and Owens, 2013). Seed orientation significantly affected corn yield in both years of the study. Seeds planted tip-down, germ with the row outyielded randomly oriented seeds by 14%. Orienting the germ across the row increased yield by another 9% (Figure 4).

Observations of leaf orientation relative to the seed germ corresponded to those from previous research showing that initial leaf orientation is strongly correlated with germ orientation, but that leaf orientation can shift during vegetative growth. First leaves were oriented within 45° of the germ direction 89% of the time, whereas this was true of only 31% of ear leaves.

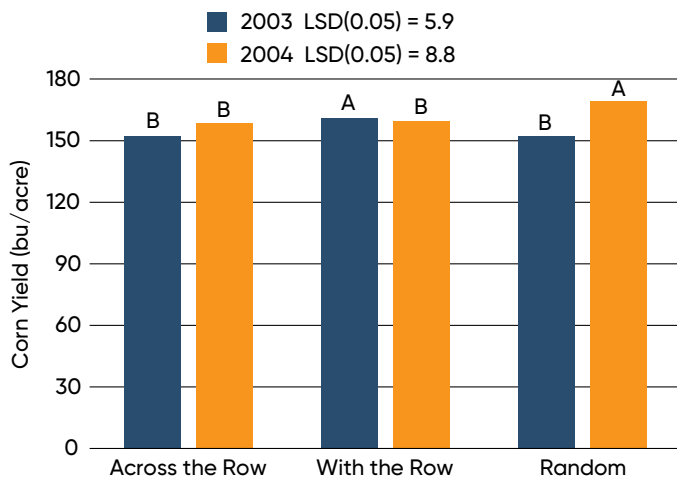


**Figure 4.** Seed orientation effects on corn yield in a 2-year Illinois State University field study (Walker and Owens, 2013).

**Oklahoma State University (2010-2012)** – An Oklahoma State University study compared the effect of several different seed orientations on plant leaf orientation in growth chamber studies (Torres et al., 2011). Results corresponded with those of previous research showing that certain seed orientations can have a strong effect on plant leaf orientation. Some seed orientations were also able to achieve faster emergence and a greater percentage of total emergence relative to randomly oriented seed. Field studies showed that controlled seed orientation improved light interception by the crop canopy and increased yield by 9% to 14% compared to randomly oriented seeds under irrigated production (Torres et al., 2017).

**Pioneer Research**

**Iowa Seed Orientation Field Study (2002-2004)** – A three-year Pioneer field study compared yield of corn planted tip-down with the germ oriented with the row, tip-down with the germ oriented across the row, and randomly (Paszkievicz et al., 2005). This study also compared seed orientation effects across a wide range of plant populations, from 18,000 to 90,000 plants/acre. Field research was conducted in Johnston, IA in 2002, 2003, and 2004. A single hybrid was used each year of the study – one hybrid in 2002 and a different hybrid in 2003 and 2004.

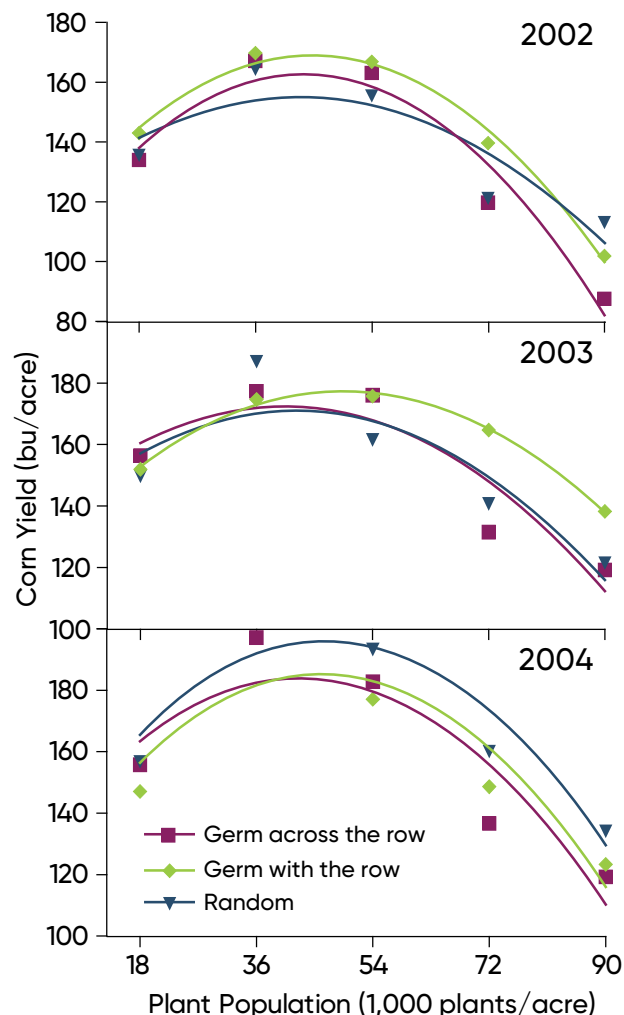


**Figure 5.** Seed orientation effects on corn yield in a 3-year Pioneer field study. Seed orientation effects were significant in two out of three years. Values with the same letter did not significantly differ within a year.

Results of the study were mixed. Seed orientation significantly impacted corn yield in two out of three years of the study (2003 and 2004) and a significant seed orientation by plant population interaction was observed in 2003. Seed planted with the germ with the row was the highest yielding in 2003 and randomly oriented seed was highest yielding in 2004 (Figure 5). The yield advantage of the with-row germ orientation in 2003 was observed at higher plant populations (Figure 6).

These results were noteworthy because seed planted with the germ oriented across the row was not advantageous to yield in any year of the study. Based on the effects of seed orientation on leaf architecture, one would expect that orienting the germ across the row could be beneficial to light interception and yield and that this benefit would tend to increase at higher plant populations as competition between plants within the row intensified, but that is not what results showed. Leaf orientation and canopy light interception were not measured in the study, but observations indicate that leaf orientation of emerged plants was highly correlated with seed orientation (Figure 3) and that across the row germ orientation likely provided some benefit to canopy light interception, at least up through the mid-vegetative growth stages. However, these effects did not result in a yield advantage.

**Iowa Leaf Orientation Field Studies (2013 and 2014)** – Field studies were conducted in 2013 and 2014 at Johnston, IA to determine if corn plants would preferentially orient their leaves toward the interrow as observed by Maddonni et



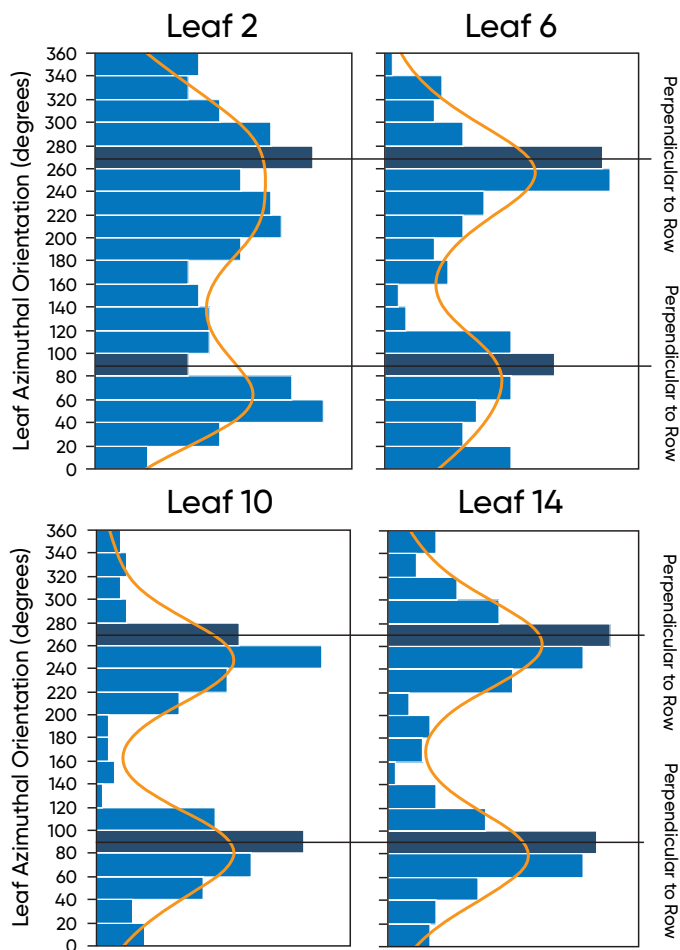
**Figure 6.** Corn yield response to seed orientation and plant population in a 3-year Pioneer field study (Paszkievicz et al., 2005).

al. (2002). These studies did not involve controlling seed orientation – plots in the studies were planted using a normal 4-row research planter and measurements were taken during the season to determine if the plants altered their leaf orientation during vegetative growth. This question is relevant to seed orientation because if hybrids are consistently able to optimize their leaf orientation, it would tend to negate some of the potential benefits of controlled seed orientation.

The 2013 study included two hybrids planted at three populations – 30,000, 40,000, and 50,000 plants/acre. Leaf orientation measurements were taken on the 15th leaf in each treatment. Plant density did not have a significant effect on leaf orientation; however, a difference was observed between the two hybrids. Plants of one of the hybrids had a greater tendency to orient their leaves toward the interrow than plants of the other hybrid (Mesick and Jeschke, 2014).

The 2014 study used two different hybrids than those in the 2013 study. The hybrids in 2014 were chosen to represent contrasting leaf types based on previous research that showed one hybrid had a more upright leaf architecture than the other (Mesick and Jeschke, 2014). For the 2014 study, orientation measurements were taken on the 2nd, 6th, 10th, and 14th leaf to determine at what growth stage

any observed changes in leaf orientation occurred. The 2014 study included the same three population densities as the 2013 study, which – once again – did not show a significant effect. Both hybrids in the 2014 study preferentially oriented their leaves toward the interrow and did so relatively early, with most of the adjustment occurring prior to the V6 growth stage (Jeschke and Uppena, 2015) (Figure 7).



**Figure 7.** Distribution of azimuthal orientation for leaf 2, leaf 6, leaf 10, and leaf 14 averaged across corn products and population densities in a Pioneer field study (Jeschke and Uppena, 2015).

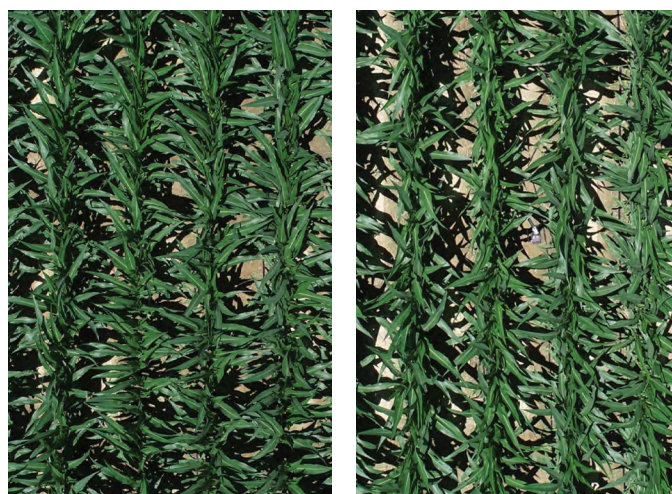
**Indiana Seed Orientation Field Demonstration (2022)** – A field demonstration was conducted in 2022 near Montgomery, Indiana to investigate the effects of corn seed orientation on speed of emergence, canopy closure, and light capture. The study compared four different seed orientations: tip down – germ across the row, tip up – germ with the row, tip down – germ with the row, and lying flat in the furrow. Time to emergence and canopy closure were recorded, as well as measurements of light capture and temperature under the canopy. Light capture was assessed by measuring the amount of light that was able to penetrate the canopy and reach ground level using an Apogee DLI-400 light meter.

Seeds planted with the tip down emerged faster than those planted tip up by approximately 20 GDUs (Emmert and Jeschke, 2022). Leaf orientation of seed planted tip down corresponded to the direction of the germ – seeds planted with germ oriented perpendicular to the row resulted in

leaves growing across the row, while seeds planted with the germ parallel to the row resulted in leaves growing with the row (Figure 8). Interestingly, seeds planted with the tip up did not result in uniform leaf orientation, even though the germ orientation was uniform. This is likely due to the circuitous path the coleoptile had to take around the kernel as it emerged.



**Figure 8.** Corn plants from seeds planted tip down with the germ oriented across the row (left) and with the row (right) showing the impact of germ direction of leaf orientation during early vegetative growth.



**Figure 9.** Corn plants from seeds planted tip down with the germ oriented across the row (left) and with the row (right) showing the impact of germ direction of leaf orientation during later vegetative growth.

Seeds planted with the tip down and germ perpendicular to the row resulted in leaves growing across the row which closed the canopy sooner than seeds planted tip down with the germ parallel to the row or seeds planted tip up (Figure 9). Light penetration through the canopy was measured from July 3 to July 13. Plots with seeds planted tip down and the germ oriented across the row captured an average of 40% more light than those with the germ oriented with the row. A period of high temperatures and drought stress occurred during late vegetative growth stages. The greater light interception in plots with leaves oriented across the row was able to reduce daytime soil surface temperatures by around 14° F.

## DOES SEED ORIENTATION MATTER?

The question of whether or not seed orientation in the furrow matters to corn growth and yield has been relegated to something of a “back-burner” issue over the years due to the lack of available planter technology capable of controlling seed orientation. The answer to the question is largely academic absent any practical means to act upon it. Probably the greater limiting factor on seed orientation research, however, has been the difficulty in doing the work. The need to precisely control the orientation of each individual seed has generally meant a lot of hand labor. The need to get a field study planted within a reasonable window of time would place significant constraints on the scale of the study and the number of factors that could be tested if each individual seed must be carefully planted by hand. Consequently, the total body of research on corn seed orientation remains relatively limited.

Based on research done so far it seems entirely plausible that controlled seed orientation could offer advantages to corn growth and yield. Studies have demonstrated the ability to influence corn emergence and canopy architecture in ways that could benefit yield performance. The amount and consistency of yield gains that can be achieved are not clear however, given the limited number of studies and mixed results that they have produced.

### Germination and Emergence

The ability to favorably influence the speed and uniformity of corn emergence by planting seeds tip-down seems fairly well-demonstrated based on previous research and the basic mechanics of corn seed germination. Patten and Van Doren (1970) showed that seeds planted tip-down achieved earlier and more complete emergence and were better able to overcome stressful conditions during germination and emergence. The field demonstration summarized by Emmert and Jeschke (2022) produced similar findings, with seeds planted tip down emerging faster than those planted tip up by approximately 20 GDUs. Granted, both studies compared tip down vs. tip up planting, ostensibly a “best case” vs. “worst case” scenario for emergence, when the more meaningful comparison from a practical standpoint would be tip down vs. random orientation. Still, based on the 20 GDU emergence difference observed in Emmert and Jeschke, that presumably would represent a 20 GDU range of variability associated with random seed orientation that could potentially be eliminated by planting all seeds tip down.

Whether that early advantage translates into increased yield is another question. In the Ohio State study, it did not, and the Pioneer field demonstration in Indiana was not taken to yield. The impact of greater speed and uniformity of corn emergence will likely depend on early season conditions. The more stressful the conditions, the more likely that factors that provide an early advantage for germination and emergence will ultimately matter to yield.

Research on other factors, such as planting depth, that influence uniformity of emergence has shown that more uniform emergence can benefit yield but is by no means guaranteed to do so. For example, a 3-year planting depth

study in Missouri found that deeper planting narrowed the window of emergence by more than two days compared to shallower planting, but did not significantly affect yield (Kitchen et al., 2021). Conversely, a planting depth study conducted in Ohio found that a 28 GDU reduction in the emergence window with deeper vs. shallower planting was associated with a significant increase in yield (Lindsey and Thomison, 2020).

### Leaf Orientation

As with emergence, the primary question regarding leaf orientation is not whether seed orientation has an impact, but whether or not that impact matters to yield. Seed planted tip down with the germ oriented

○ *“Based on research done so far it seems entirely plausible that controlled seed orientation could offer advantages to corn growth and yield.”*

across the row would seem to represent the ideal orientation to optimize leaf orientation. The 2022 Pioneer field demonstration showed greater light interception and reduced soil temperature under the canopy with across the row vs. with the row seed orientation. Both the Illinois State University field study and the Pioneer field study (2002–2004) compared yield of corn planted tip-down with the germ oriented with the row, tip-down with the germ oriented across the row, and randomly. Results differed between the two studies, however. The Illinois State study showed an advantage to across the row germ orientation and the Pioneer study did not.

One notable difference between the two studies was the yield environment in the years the studies were conducted. The two years of the Illinois State study (2011–2012) were characterized by drought stress and below trendline yields in Central Illinois; whereas the three years of the Pioneer field study (2002–2004) all had above trendline yields in Central Iowa. It seems plausible that earlier and more complete canopy closure could confer a greater benefit to crop performance and yield under more stressful conditions by increasing light interception and helping preserve soil moisture through greater shading of the soil surface.

The ability of corn plants to alter their leaf orientation adds another layer of uncertainty to the potential value of controlled seed orientation. If modern hybrids are generally able to adapt their leaf orientation and shift leaf growth toward the interrow, it would reduce the need to control seed orientation to optimize canopy architecture. This capacity has been shown to differ among hybrids, but the extent to which it varies across modern hybrids more broadly is unknown. Of the four hybrids tested in Pioneer field studies, three were readily able to adapt their leaf orientation. The potential introduction of reduced-stature corn hybrids later this decade adds yet another layer of uncertainty, since it would involve a significant change to the structure of the crop canopy compared to current hybrids. Whether the shorter internode length of reduced-stature plants has any impact on their capacity to adjust their leaf orientation in response to neighboring plants is not known at this point.

# Corn Yield Response to Plant Population in Central and Eastern Ontario

Paul Hermans and James D'Aoust, Sales Agronomists, and Mark Jeschke, Ph.D., Agronomy Manager

## KEY FINDINGS

- Corn yield increased with plant population in on-farm trials in Central and Eastern Ontario in 2022.
- Eastern Ontario locations were generally higher yielding and showed a relatively strong relationship between plant population and corn yield.
- Corn yields at Central Ontario locations were generally lower, more variable and less affected by plant population; likely due to greater drought stress in the region.

## HYBRID RESPONSE TO POPULATION – 2022 TRIALS

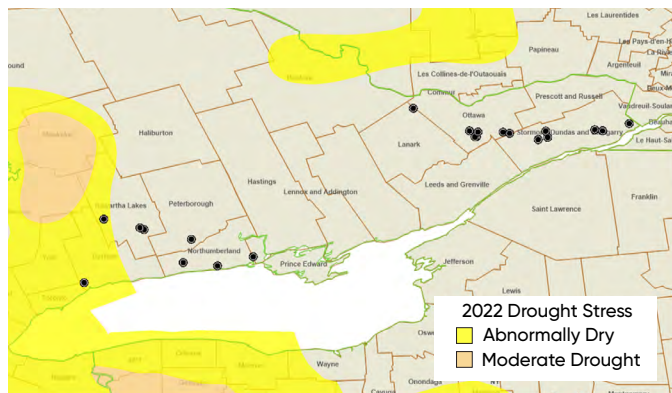
- On-farm trials evaluating corn hybrid response to plant population were conducted at 22 locations across Central and Eastern Ontario in 2022.
- Hybrids were planted at three to five different populations at each location. Most locations included four populations: 26,000, 30,000, 34,000, and 38,000 plants/acre.
- A total of six different Pioneer® brand corn products were included in the study (Table 1).
- Each location had either one or two replications.

**Table 1.** Pioneer brand corn products included in 2022 on-farm population trials and the number of locations for each.

Hybrid/Brand <sup>1</sup>	Number of Locations
P8859AM™ (AM,LL,RR2)	4
P9233AM™ (AM,LL,RR2)	4
P9316Q™ (Q,LL,RR2)	11
P9535AM™ (AM,LL,RR2)	11
P9823Q™ (Q,LL,RR2)	7
P9845AM™ (AM,LL,RR2)	7

## RESULTS

- The Eastern Ontario locations were generally higher yielding, with an average yield of 232 bu/acre compared to an average of 186 bu/acre for the Central Ontario locations.
- The lower yield of the Central Ontario locations can be attributed to lower rainfall, which led to drought stress at some locations.



**Figure 1.** Corn plant population trial locations in Central and Eastern Ontario in 2022.

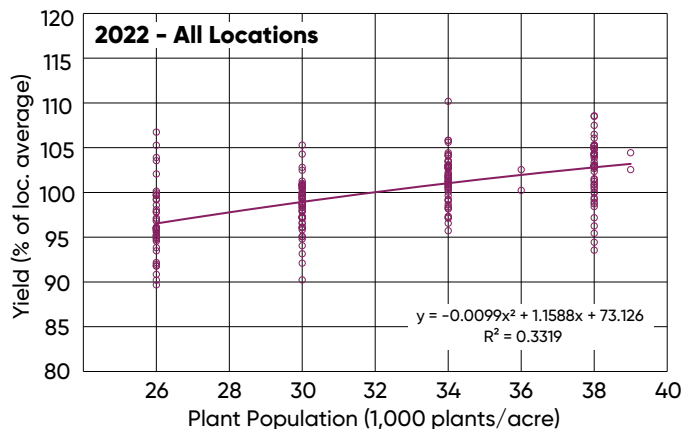
**Table 2.** Monthly rainfall totals at towns near Central and Eastern Ontario plant population trial locations.

### Central Locations

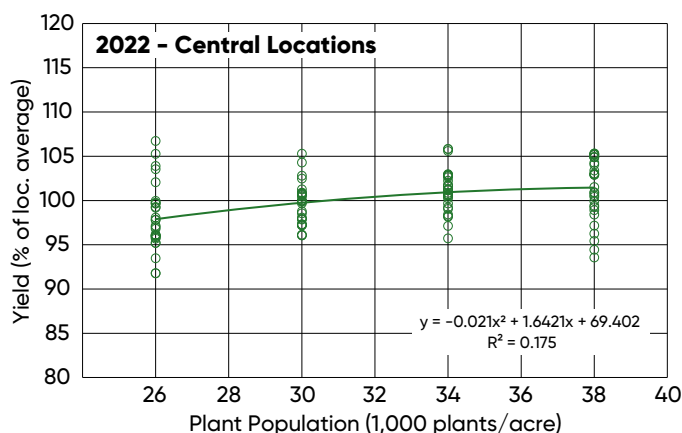
Town	May	June	July	August	Total
mm					
Grafton	56	46	80	44	225
Keene	48	28	52	68	195
Quinte West	78	82	83	82	324
Lindsay	54	92	88	78	312
Goodwood	41	75	56	78	250
Sunderland	1	82	55	47	185
<b>Average</b>	<b>46</b>	<b>67</b>	<b>69</b>	<b>66</b>	<b>248</b>

### Eastern Locations

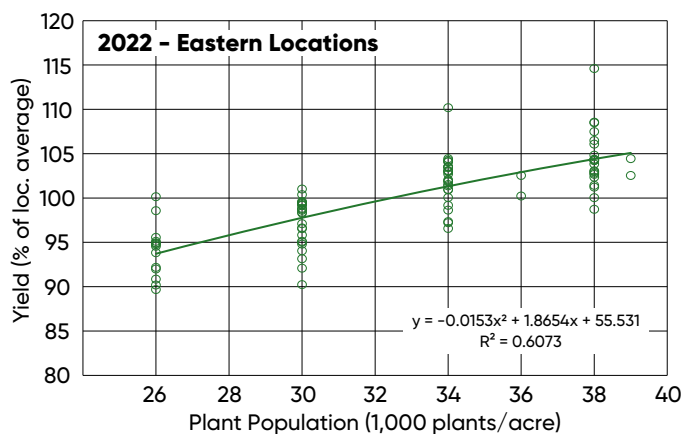
Town	May	June	July	August	Total
mm					
Pakenham	63	59	65	126	314
North Gower	81	68	63	141	353
South Mountain	94	85	99	84	362
Chesterville	86	95	79	106	365
Finch	69	74	60	131	334
Bainsville	59	98	58	48	263
<b>Average</b>	<b>75</b>	<b>80</b>	<b>71</b>	<b>106</b>	<b>332</b>



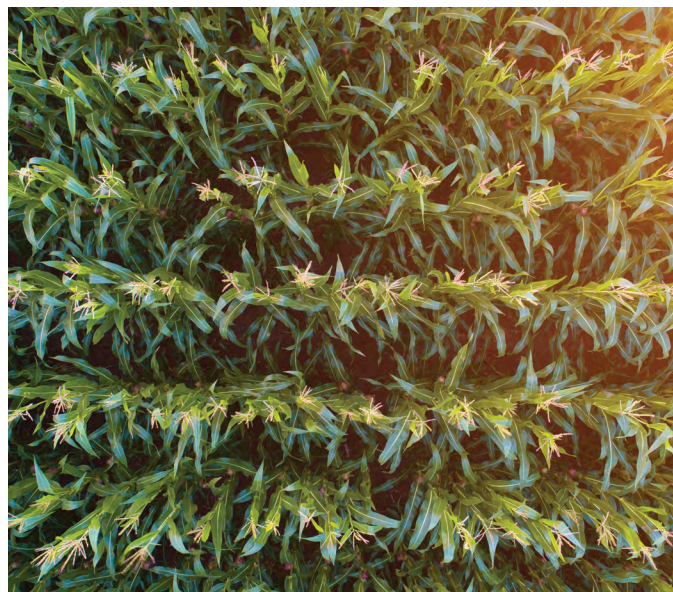
**Figure 2.** Corn yield response to population across all hybrids and locations. Corn yield is expressed as a percent of the location average.



**Figure 3.** Corn yield response to population across 12 Central Ontario locations. Corn yield is expressed as a percent of the location average.



**Figure 4.** Corn yield response to population across 10 Eastern Ontario locations. Corn yield is expressed as a percent of the location average.



- Across all study locations corn yield increased linearly with plant population (Figure 2).
- The highest seeding rate of 38,000 plants/acre at most locations was not high enough to observe a plateau in the population response or establish an agronomically optimum plant population.
- Across the 12 Central Ontario locations, corn yield increased slightly with plant population, but the yield data were highly variable and the relationship to plant population was relatively weak (Figure 3).
- Weather, particularly rainfall, was a key differentiating factor in yield outcomes between Central and Eastern Ontario.
- Lower precipitation and a greater occurrence of drought stress at some of the Central Ontario locations likely contributed to the variability in yield.
- Across Eastern Ontario locations, where corn yield was generally higher, yield also increased with plant population but to a greater extent and with a stronger relationship between population and yield (Figure 4).

### Acknowledgment

Special thanks to our plot co-operators and project supporters:

**Eastern Ontario:** Emerald Acres, J&H Nixon Farms, Hog Haven Inc., Golden Rail Farms, Vernon Valley Farms, Vanden Bosch Farms, Fife Agronomics, Jim Parks, Velthuis Farms Ltd., David Renaud and Rob Willoughby

**Central Ontario:** Reesor Seed & Grain, Parbro Farms Ltd, Ryan Svendsen, Ray Cann Farming Ltd, Glen Isle Farms Ltd, Jeff Harrison Farms Ltd, Hollowdale Cattle Company Ltd, Greydafton Farms Inc.

# Managing Corn for Greater Yield Potential

Mark Jeschke, Ph.D., Agronomy Manager

- Improved hybrids and production practices are helping corn growers increase yields. Over the past 30 years, U.S. yields have increased by an average of 2 bu/acre/year.
- The NCGA National Corn Yield Contest provides a benchmark for yields that are attainable when conditions and management are optimized.
- The 2022 contest had 282 entries that exceeded 300 bu/acre, the second-most ever, but down sharply from 2021.
- Pioneer brand products were used in more entries exceeding 300 bu/acre than any other individual seed brand, with 30 different hybrid families achieving this yield level.
- Plant populations in high yield entries were generally above average but not extraordinarily high, with most falling between 34,000 and 38,000 plants/acre.
- High yield entries tended to be planted earlier than average. Weather-related planting delays across much of the Corn Belt in 2022 likely contributed to the lower number of 300 bu/acre entries compared to 2021.
- The vast majority of high yield entries were planted in 30-inch rows, reflecting overall industry trends.
- Nearly 80% of 300 bu/acre entries included some form of in-season nitrogen application.

*"Pioneer® brand products were used in 200 NCGA National Corn Yield Contest state-level winning entries in 2022 – more than any other seed brand."*



## BENCHMARKING YOUR CORN YIELD

Since the introduction of hybrid corn nearly a century ago, corn productivity improvements have continued through the present day. Over the last 30 years, U.S. corn yield has increased by an average of 2 bu/acre per year. These gains have resulted from breeding for increased yield potential, introducing transgenic traits to help protect yield, and agronomic management that has allowed yield potential to be more fully realized.

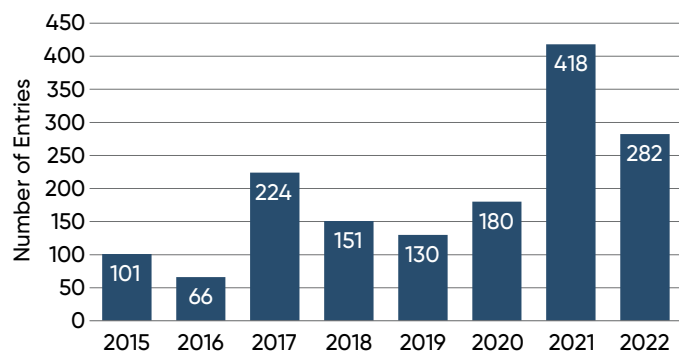
As growers strive for greater corn yields, the National Corn Growers Association (NCGA) National Corn Yield Contest provides a benchmark for yields that are attainable when environmental conditions and agronomic management are optimized. The average yields of NCGA winners are nearly double the average U.S. yields.



### 2022 NCGA National Corn Yield Contest Trends

The 2022 growing season was generally a down year for corn yields. The USDA estimated average yield was 172.3 bu/acre, which was 4 bu/acre less than 2021 and below the long term trendline. Corn yields were up over 2021 in Illinois and in the northern Corn Belt states of Wisconsin, Minnesota, and North Dakota, which rebounded from poor yield performance in 2021 driven by hot and dry conditions. However, corn yields were down in most other corn-producing states, and down sharply in the Southeast and Great Plains. Drought stress was a major yield-limiting factor in 2022, affecting large portions of the country over the course of the year.

Corn yields in the NCGA National Corn Yield Contest followed the overall downward trend in corn yield in 2022. The number of high-yield entries – defined for the purposes of this discussion as all entries yielding over 300 bu/acre – totaled 282 (Figure 1). This was the second-highest number of 300 bu/acre entries ever in the contest, but down sharply from the all-time high of 418 entries set in 2021.



**Figure 1.** Total entries in the NCGA National Corn Yield Contest exceeding 300 bu/acre by year from 2015 to 2022.

Contest yields exceeding 300 bu/acre were achieved in 31 different states. The majority of high yield entries were right in the heart of the Corn Belt. Nebraska alone accounted for nearly 100 high yield entries, nearly all of which were irrigated. Iowa, Illinois, Indiana, and Ohio added another 80 (Table 1).

**Table 1.** Number of NCGA National Corn Yield Contest entries over 300 bu/acre by state, 2018-2022.

State	2018	2019	2020	2021	2022
	number of entries				
AL	3	5	4	2	3
AR	1	0	1	4	1
CA	3	3	2	1	0
CO	1	0	1	13	6
DE	0	6	0	7	7
FL	0	0	0	0	0
GA	0	7	5	7	7
IA	8	3	6	33	11
ID	8	1	3	5	1
IL	18	6	19	37	28
IN	17	8	23	34	26
KS	3	2	6	13	9
KY	4	3	3	24	1
MA	2	4	1	0	0
MD	2	5	3	8	13
MI	1	4	3	14	2
MN	0	0	5	3	4
MO	4	3	11	15	9
NC	1	3	0	4	1
NE	39	7	37	96	95
NH	0	0	0	0	1
NJ	1	9	9	10	4
NM	0	1	0	0	0
NY	0	0	0	1	0
OH	2	2	6	25	15
OK	2	0	2	7	2
OR	4	7	0	0	4
PA	0	15	0	2	2
SC	0	4	3	5	0
SD	0	0	2	3	1
TN	2	3	3	8	1
TX	7	1	2	5	3
UT	6	0	2	6	4
VA	2	9	0	12	5
WA	9	7	3	4	3
WI	1	1	13	8	12
WV	0	1	2	1	1
WY	0	0	0	1	0

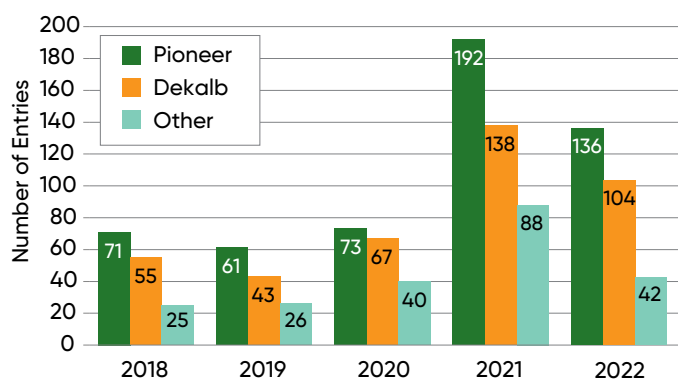
## HYBRID SELECTION

Hybrids tested against each other in a single environment (e.g., a university or seed company test plot) routinely vary in yield by at least 30 bu/acre. At contest yield levels, hybrid differences can be even higher. That is why selecting the right hybrid is likely the most important management decision of all those made by contest winners.

The yield potential of many hybrids now exceeds 300 bu/acre. Realizing this yield potential requires matching hybrid characteristics with field attributes, such as moisture supplying capacity; insect and disease spectrum and intensity; maturity zone, residue cover; and even seedbed temperature. To achieve the highest possible yields, growers should select a hybrid with:

- Top-end yield potential.** Examine yield data from multiple, diverse environments to identify hybrids with highest yield potential.
- Full maturity for the field.** Using all of the available growing season is a good strategy for maximizing yield.
- Good emergence under stress.** This helps ensure uniform stand establishment and allows earlier planting, which moves pollination earlier to minimize stress during this critical period.
- Above-average drought tolerance.** This will provide insurance against periods of drought that most non-irrigated fields experience.
- Resistance to local diseases.** Leaf, stalk, and ear diseases disrupt normal plant function, divert plant energy, and reduce standability and yield.
- Traits that provide resistance to major insects,** such as corn borer, corn rootworm, black cutworm, and western bean cutworm. Insect pests reduce yield by decreasing stands, disrupting plant functions, feeding on kernels, and increasing lodging and dropped ears.
- Good standability** to minimize harvest losses.

Pioneer® brand products were used in 200 NCGA National Corn Yield Contest state-level winning entries in 2022 – more than any other seed brand. State-level winners included a total of 80 different Pioneer brand products from 62 different hybrid families ranging from 91 to 120 CRM (Appendix).



**Figure 2.** Seed brand planted in National Corn Yield Contest entries exceeding 300 bu/acre from 2018 to 2022.

The brands of seed corn used in the highest yielding contest entries in 2018 through 2022 are shown in Figure 2. In all years, Pioneer brand products were used in more entries exceeding 300 bu/acre than any other individual seed brand.

Yields exceeding 300 bu/acre have been achieved using Pioneer® brand products from 72 different hybrid families over the past five years, ranging from 97 to 120 CRM. The top-performing Pioneer hybrid families in the National Corn Yield Contest are shown in Table 2. The Pioneer brand P1185 family of products has been the top performer in the contest over the past few years, topping 300 bu/acre 59 times since 2020. Pioneer brand P1185, P1563, P0953, and P2042 families all had 10 or more entries over 300 bu/acre in 2022.

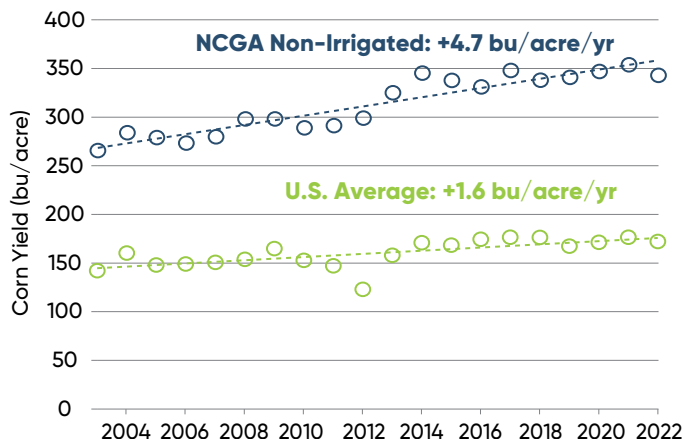
**Table 2.** Pioneer hybrid families with the most entries over 300 bu/acre in the 2022 NCGA National Corn Yield Contest.

Hybrid Family	2018	2019	2020	2021	2022	2018-2022
	number of entries					
P1185			10	29	20	59
P1563	3	1	11	22	15	52
P0953				11	10	21
P2042				5	10	15
P1718					9	9
P1742					8	8
P1222				5	6	11
P0924				4	6	10
P1170					5	5
P1572			6	7	4	17
P1359			1	6	4	11
P1828	8	4	6	5	4	27
P1136					4	4
P1847		4	2	9	3	18
P1082		1	2	7	3	13
P1383					3	3
P0908					3	3
P1108		1	3	10	2	16
P1197	11	11	6	8	2	38
P1055				1	2	3
P0817				1	2	3
P1370	5		2		2	9
P1278					2	2
P9998	2	3		2	1	8
P0421				2	1	3
P0947				1	1	2
P0950	2				1	3
P9772					1	1
P1548					1	1
P0995					1	1

## HIGH-YIELD MANAGEMENT PRACTICES

Top performers in the NCGA yield contest not only have produced yields much higher than the current U.S. average, they have also achieved a higher rate of yield gain over time. Over the past 20 years, U.S. corn yields have increased at a rate of 1.6 bu/acre per year while winning yields in the non-irrigated yield contest classes have increased by 4.7 bu/acre

per year. Contest fields are planted with the same corn hybrids available to everyone and are subject to the same growing conditions, which suggests that management practices are playing a key role in capturing more yield potential. The following sections will discuss management practices employed in contest entries yielding above 300 bu/acre.

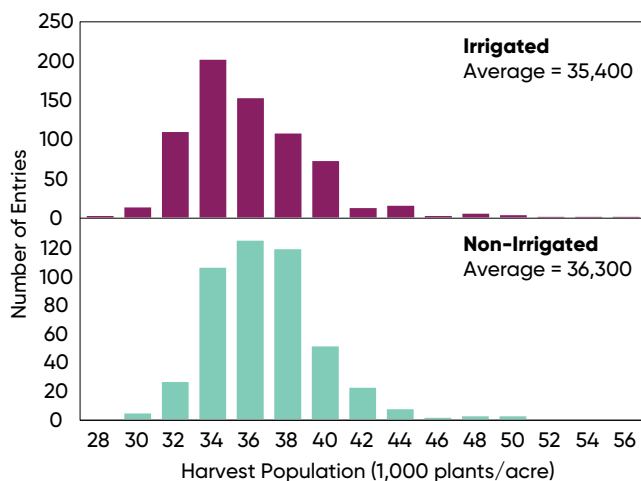


**Figure 3.** Average yields of NCGA National Corn Yield contest non-irrigated class national winners and U.S. average corn yields, 2003-2022.

## PLANTING PRACTICES

### Plant Population

One of the most critical factors in achieving high corn yields is establishing a sufficient population density to allow a hybrid to maximize its yield potential. Historically, population density has been the main driver of yield gain in corn – improvement of corn hybrid genetics for superior stress tolerance has allowed hybrids to be planted at higher plant populations and produce greater yields.



**Figure 4.** Harvest populations and corn yield of irrigated and non-irrigated NCGA National Corn Yield Contest entries exceeding 300 bu/acre, 2018-2022.

Harvest populations in irrigated and non-irrigated national corn yield contest entries over 300 bu/acre from 2018 through 2022 are shown in Figure 4. The average harvest population of non-irrigated entries (36,300 plants/acre) was slightly greater than that of irrigated entries (35,400 plants/acre) over five years. Both are well above the USDA average plant

population of 29,200 plants/acre, as would be expected for high-yielding environments. However, yields over 300 bu/acre were achieved over a wide range of populations, from 28,000 to 56,000 plants/acre, demonstrating that exceptionally high populations are not necessarily a prerequisite for high yields. Although population density is important in establishing the yield potential of a corn crop, it is just one of many factors that determine yield.

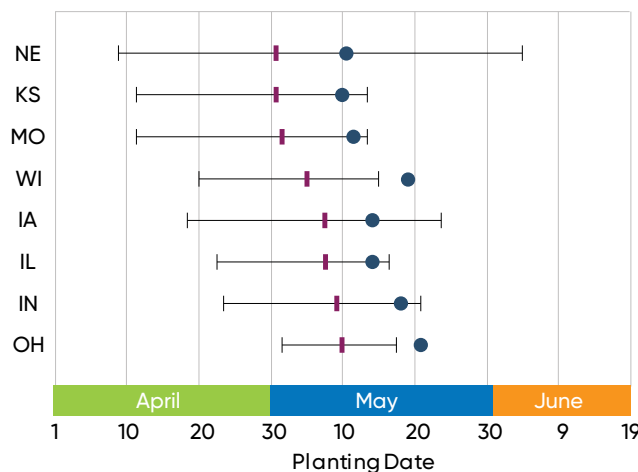
### Planting Date

High-yielding contest plots are usually planted as early as practical for their geography. Early planting lengthens the growing season and, more importantly, moves pollination earlier. When silking, pollination and early ear fill are accomplished in June or early July, heat and moisture stress effects can be reduced.

Planting dates for entries exceeding 300 bu/acre ranged from April 9 to June 4 in the Corn Belt states shown in Figure 5, with average planting dates for all states falling within the first 10 days of May. The planting window for high yield entries was generally on the early side of planting progress overall. In all states, the average planting date for high yield entries occurred several days ahead of the mid-point of corn planting progress according to USDA NASS data (Figure 5).

Planting was delayed throughout much of the Corn Belt in 2022 due to below average temperatures in April, running about two weeks behind 2021 planting progress. Planting dates for high yield entries were also later in 2022, with many entries planted in early May compared to mid- to late April in 2021. States that experienced longer planting delays compared to 2021 also tended to have a greater drop-off in the number of 300 bu/acre entries from 2021, suggesting that some of the top-end yield potential was lost with later planting. The 2022 contest had several high-yield entries planted in mid- to late-May and even early June, demonstrating that high yields can still be achieved under favorable conditions if planting is not delayed for too long. However, the odds of achieving high yields are generally going to be better with earlier planting.

- 300 bu/acre Entries Planting Date (min - average - max)
- Corn Planting 50% Completed (USDA NASS)

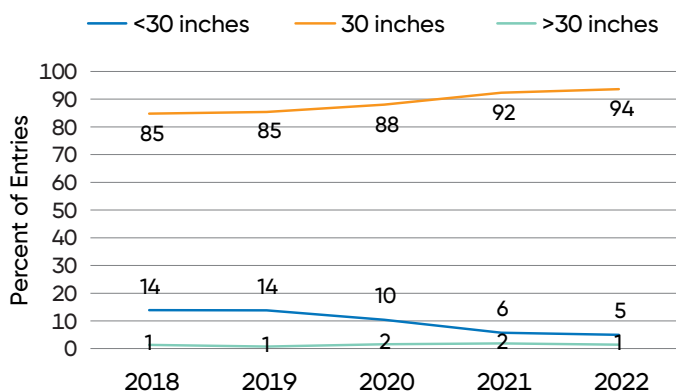


**Figure 5.** Average planting date and planting date range of NCGA National Corn Yield Contest entries exceeding 300 bu/acre in 2022 in select states.

## Row Spacing

The vast majority of corn acres in the U.S. are currently planted in 30-inch rows, accounting for over 85% of corn production. A majority of 300 bu/acre contest entries over the past five years have been planted in 30-inch rows (Figure 6). This proportion has increased slightly in recent years as wider row configurations (most commonly 36-inch or 38-inch) have remained steady and narrower row configurations (15-inch, 20-inch, 22-inch or 30-inch twin) have declined.

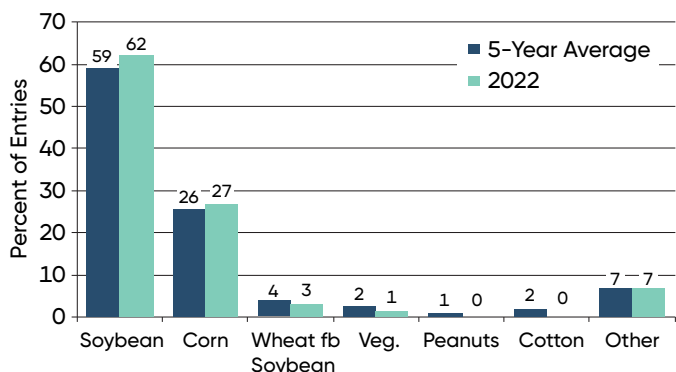
Row spacings narrower than the current standard of 30 inches have been a source of continuing interest as a way to achieve greater yields, particularly with continually increasing seeding rates. However, research has generally not shown a consistent yield benefit to narrower rows outside of the northern Corn Belt (Jeschke, 2018).



**Figure 6.** Row width used in NCGA National Corn Yield Contest entries exceeding 300 bu/acre, 2018-2022.

## CROP ROTATION

Rotating crops is one of the practices most often recommended to keep yields consistently high. Rotation can break damaging insect and disease cycles that lower crop yields. Including crops like soybean or alfalfa in the rotation can reduce the amount of nitrogen required in the following corn crop. A majority of the fields in the 300 bu/acre entries were planted to a crop other than corn the previous growing season (Figure 7).



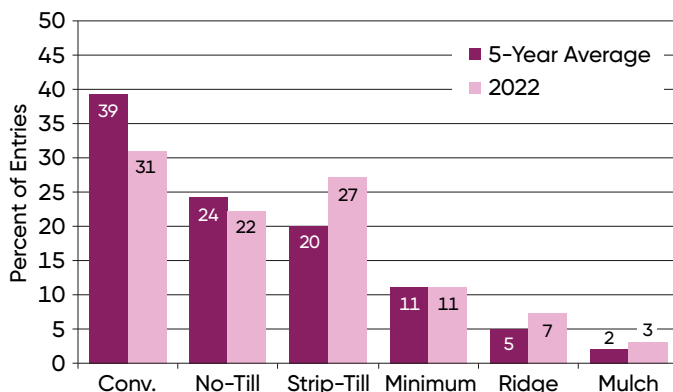
**Figure 7.** Previous crop in NCGA National Corn Yield Contest entries exceeding 300 bu/acre in 2022 and 5-year averages.

The so-called “rotation effect” is a yield increase associated with crop rotation compared to continuous corn even when all limiting factors appear to have been controlled or adequately supplied in the continuous corn. This yield increase has averaged about 5% to 15% in research studies but has generally been less under high-yield conditions (Butzen, 2012). Rotated corn is generally better able to tolerate yield-limiting stresses than continuous corn; however, yield contest results clearly show that high yields can be achieved in continuous-corn production.

## TILLAGE

Over the past five years, around 40% of the high yield entries in the NCGA contest have used conventional tillage, with the other half using no-tillage or some form of reduced tillage (Figure 8). The proportion of high-yield entries using conventional tillage has declined over time, offset by increases in no-till and strip-till.

“The proportion of high-yield entries using conventional tillage has declined over time, offset by increases in no-till and strip-till.”



**Figure 8.** Tillage practices in NCGA National Corn Yield Contest entries exceeding 300 bu/acre in 2022 and 5-year averages.

## NUTRIENT MANAGEMENT

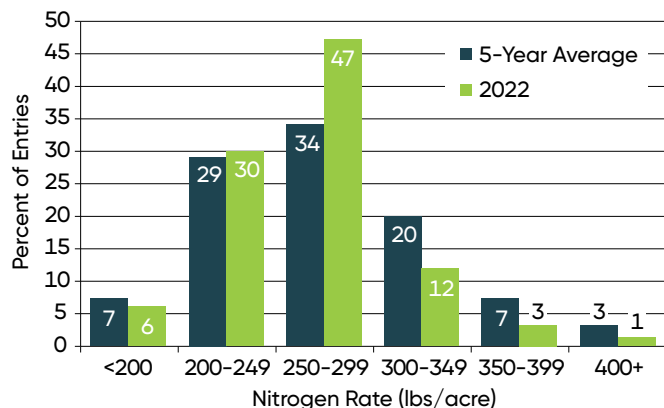
Achieving highest corn yields requires an excellent soil fertility program, beginning with timely application of nitrogen (N) and soil testing to determine existing levels of phosphorous (P), potassium (K), and soil pH.

### Nitrogen

Corn grain removes approximately 0.67 lbs of nitrogen per bushel harvested, and stover production requires about 0.45 lbs of nitrogen for each bushel of grain produced (IPNI, 2014). This means that the total N needed for a 300 bu/acre corn crop is around 336 lbs/acre. Only a portion of this amount needs to be supplied by N fertilizer; N is also supplied by the soil through mineralization of soil organic matter. On highly productive soils, N mineralization will often supply the majority of N needed by the crop. Credits can be taken for previous

legume crop, manure application, and N in irrigation water. Nitrogen application rates of entries exceeding 300 bu/acre are shown in Figure 9.

The N application rates of 300 bu/acre entries varied greatly, but the majority were in the range of 200 to 300 lbs/acre. Some entries with lower N rates were supplemented with N from manure application. As corn yield increases, more N is removed from the soil; however, N application rates do not necessarily need to increase to support high yields. Climatic conditions that favor high yield will also tend to increase the amount of N a corn crop obtains from the soil through increased mineralization of organic N and improved root growth.



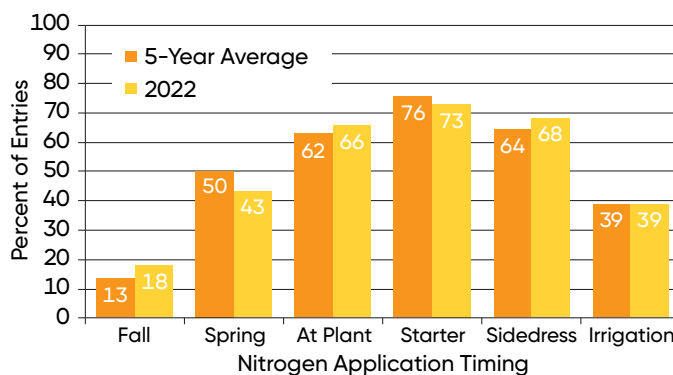
**Figure 9.** Nitrogen rates (total lbs/acre N applied) of NCGA National Corn Yield Contest entries exceeding 300 bu/acre in 2022 and 5-year averages.

Total nitrogen applied in high yield entries has trended downward in recent years. In the 2016 contest, over half of high yield entries had over 300 lbs/acre of N applied, compared to less than 20% of entries in 2022.

Timing of N fertilizer applications can be just as important as application rate. The less time there is between N application and crop uptake, the less likely N loss from the soil will occur and limit crop yield. Nitrogen uptake by the corn plant peaks during the rapid growth phase of vegetative development between V12 and VT (tasseling). However, the N requirement is high beginning at V6 and extending to the R5 (early dent) stage of grain development.

“Nearly 80% of 300 bu/acre entries included some form of in-season nitrogen, either side-dressed or applied with irrigation.”

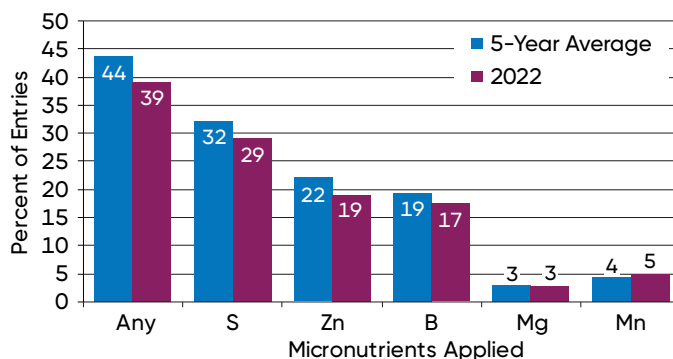
Timing of N fertilizer applications in 300 bu/acre entries is shown in Figure 10. Very few included fall-applied N. Many applied N before or at planting. Nearly 80% of 300 bu/acre entries included some form of in-season nitrogen, either side-dressed or applied with irrigation. Multiple nitrogen applications were used in 94% of high-yield entries.



**Figure 10.** Nitrogen fertilizer application timing of NCGA National Corn Yield Contest entries exceeding 300 bu/acre in 2022 and 5-year averages.

**Micronutrients**

Micronutrients were applied on 39% of the 300 bu/acre entries (Figure 11). The nutrients most commonly applied were sulfur (S), zinc (Zn), and boron (B), with some entries including magnesium (Mg), manganese (Mn), or copper (Cu). Micronutrients are sufficient in many soils to meet crop needs. However, some sandy soils and other low organic matter soils are naturally deficient in micronutrients, and high pH soils may reduce their availability (Butzen and Jeschke, 2022). Additionally, as yields increase, micronutrient removal increases as well, potentially causing deficiencies.



**Figure 11.** Micronutrients applied in NCGA National Corn Yield Contest entries exceeding 300 bu/acre in 2022 and 5-year averages.

# Exploring the Potential for Reduced-Stature Corn

*Robert Gunzenhauser, Research Scientist*

- Reduction of plant height has been an important innovation for increasing yields in wheat and rice by increasing the harvest index and making plants less prone to lodging.
- In corn, more than 25 single-gene mutations have been identified that affect plant structure. These mutations generally fall into two effect categories – influence on hormone levels or influence on hormone response.
- The potential for developing reduced-stature corn has been explored for decades, with research by Corteva Agriscience's legacy companies dating back as far as the 1940s.
- Reducing plant height in corn makes the plants better able to withstand high winds and increases accessibility for in-season applications without the need for high-clearance or aerial equipment.
- Research and development at Corteva Agriscience are presently being performed to bring the best genetics to farmers' fields and the management guidance for greatest benefit with reduced-stature corn.

## HIGHER YIELD THROUGH SHORTER PLANTS

Reduced-stature corn (RSC), also referred to as “dwarf” or “short” corn, is a concept that has received increased attention in recent years. Reduction of plant height has been an important innovation in other crops such as wheat and rice but so far has not been successfully deployed in corn, despite numerous attempts over the past several decades. Today, the need to continue driving higher yield in corn as well as increase resilience against severe weather has brought about a renewed focus on the concept of reduced-stature corn. This article provides an overview on how reduced-stature corn is developed, the intended benefits, and some of the agronomic considerations that are being studied by Corteva Agriscience.

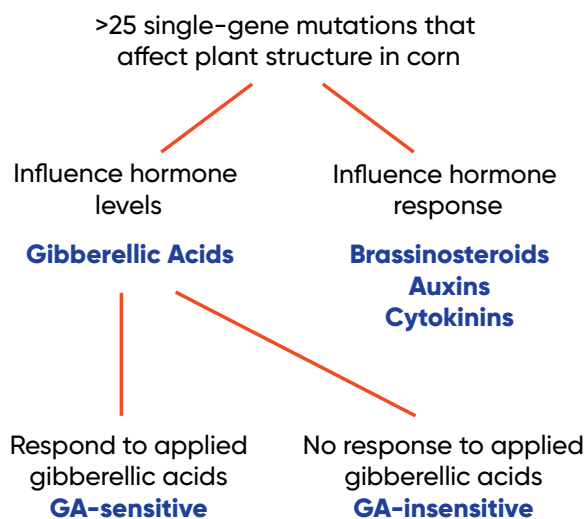


**Figure 1.** A research trial of Corteva Agriscience reduced-stature corn being harvested with a plot combine.

## REDUCING PLANT HEIGHT IN CORN

Improving the yield and standability of grain crops by reducing plant height has played an important role in global food production and food security over the past 70 years. The breeding of dwarf crops gained traction in the early 1950s with the introduction of semi-dwarf wheat varieties developed by Norman Borlaug after crossing a dwarf Japanese variety, ‘Norin 10,’ with various Mexican varieties. The benefit of the resulting semi-dwarf wheat varieties was reduced lodging of the crop, especially under higher nitrogen and irrigation applications. Another benefit was that more energy and nutrients went into grain development, leading to an increased harvest index (ratio between grain mass and total above ground biomass). This generated greater yields and made Mexico self-sufficient in wheat production shortly after development. This in turn led to the Green Revolution with the semi-dwarf wheat varieties finding their way to India and Pakistan. This same approach of breeding dwarf genes into crops has been used in rice and sorghum as well.

In corn, more than 25 single-gene mutations have been identified that affect plant structure. These mutations generally fall into two effect categories – influence on hormone levels or influence on hormone response. For the gene mutations that influence hormone levels, gibberellic acids are the primary focus. They promote stem and internode elongation, along with many other physical traits. Plant varieties with identified genes that are either GA-deficient or GA-insensitive tend to have shorter stature than wild-type cultivars. These genes can be altered by biotechnology processes or bred into improved genetics to generate reduced-stature varieties.



The potential utility of reduced-stature corn has been evaluated by Pioneer in the past. Efforts at developing “dwarf corn” took place in the late 1940s (Figure 2). An article published in the July 1960 Pioneer Kernels newsletter summarized findings of contemporary research on dwarf corn hybrids. The article stated that, based on experiments conducted in the prior year, dwarf hybrids did offer improved lodging resistance but did not compete in yield with the then-current standard stature hybrids, and that unfavorable growing conditions could make the dwarf hybrids place ears too low for mechanical picking. However, the article was hopeful that certain dwarf traits could be bred into taller varieties to reduce plant height without losing yield or creating ear placement concerns.



**No Stretch Detasseling Here.** These two detasslers stoop rather than reach for tassels in this field. It's an isolated field for making a new dwarf hybrid near Johnston, Iowa. On the left is Ed Pixley, a Drake student, and on the right is Howard Richardson, a student at Iowa State College.

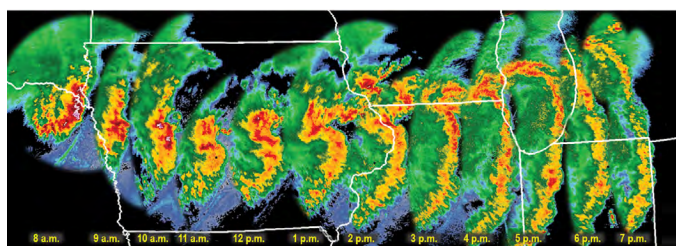
**Figure 2.** Images that appeared in the Pioneer Kernels Newsletter in the late-1940s showcasing early work by Pioneer Hi-Bred with dwarf hybrid corn.



These Pioneer salesmen just couldn't believe that these big 12-inch ears were growing on those short dwarf hybrid stalks. After Dick Van Zee, Prairie City, Iowa, got down on his knee and examined the ears he believed it but was amazed. Their names are (left to right): John Michener, Milo, Iowa; Clifford M. Klein, Newton, Iowa; Harry C. Tinnermeier, Newton, Iowa; and Wayne I. Beaver, Bussey, Iowa.

## WHY THE RENEWED INTEREST IN REDUCED-STATURE CORN NOW?

One of the factors leading to renewed interest in reduced-stature corn was the August 2020 derecho wind event that hit the Central Corn Belt in the Midwestern U.S., knocking over millions of acres of corn with sustained wind speeds 70 to 120 miles-per-hour (Figure 3). In many cases the corn was flattened so much that it could not be harvested and had to be destroyed through shredding and tillage (Figure 4).



**Figure 3.** August 10, 2020, derecho: Lowest angle NWS radar reflectivity at one-hour time steps (NWS Chicago).

The 2020 derecho was unique in its scale and severity but was also part of a broader trend of more intense and damaging wind events. The central U.S. has experienced an increase in the frequency and intensity of severe straight line wind events over the past 40 years due to rising temperatures (Prein, 2023). As this trend continues to intensify in coming years, so too will the risk of corn yield loss due to wind-induced lodging. Making corn plants better able to withstand high winds will be an important component of building more stable and resilient agricultural systems.

Even before this massive wind event galvanized renewed interest in reduced-stature corn, scientists at Corteva Agriscience and its legacy companies had been developing and testing reduced-stature corn for over 20 years through various biotech and breeding programs. Over the course of this period, scientists evaluated multiple genes and approaches for incorporating reduced-stature into elite corn genetics. Some genes and approaches were not successful; much like previous attempts, they were able to achieve reduced-stature in corn but not without compromising yield and/or harvestability. The approach currently being tested appears to offer the best combination of yield potential, resistance to lodging, and harvestability.



**Figure 4.** A corn field flattened by the high winds of the August 2020 derecho near Adel, Iowa. Photo: Lisa Schmitz - National Weather Service (Des Moines Office).





**Figure 5.** Standard-stature corn (top) and reduced-stature corn (above) at the V8 growth stage.

## CHARACTERISTICS OF CORTEVA AGRISCIENCE'S REDUCED-STATURE CORN

Reduced-stature corn that has been developed and is currently being evaluated by researchers at Corteva Agriscience is typically 60 to 76 inches tall (152 to 193 cm) at full height, with an ear height of 24 to 36 inches (61 to 91 cm) under typical growing conditions (Figure 6). Reduction in plant stature is achieved by uniformly reducing the length of internode distances between leaves over the entire height of the plant.

Reduced-stature plants have the same number of leaves as standard-stature corn with similar relative maturity; however, the leaves are typically shorter in length and wider. Leaf area index (the total amount of leaf area per unit area) is very similar between reduced- and standard-stature corn, which is critical for maximizing light capture and yield potential.

Stalks are generally 10%-25% larger in diameter in reduced-stature corn compared to standard-stature (1-1/8 inches (2.8 cm) for RSC vs 3/4 - 1 inch (1.9 to 2.5 cm) for SSC). Reduced-stature corn can also be more prolific (multiple ears per plant) and produce more tillers than standard-stature hybrids in

some instances. The reduction in stalk length means that reduced-stature corn has less aboveground biomass than standard-stature corn, which may offer an advantage in areas where residue management is a challenge.



**Figure 6.** Reduced-stature corn next to a current commercial hybrid in the Corteva Agriscience field demonstration plots at Johnston, IA, July 2023.



**Figure 7.** A block of reduced-stature corn surrounded by severely lodged standard-stature corn at the Corteva Agriscience Marion, IA, research station following a severe wind event in August 2021. Photo courtesy of Deborah Montezano.

## BENEFITS OF REDUCED-STATURE CORN

Reduced-stature corn is less likely to be lodged, or blown over, during high wind events due to its shorter profile and thicker stalks (Figure 7). Reduced-stature corn has been tested by Corteva Agriscience using its Boreas wind machines for green snap and root lodging and was found to lodge much less than standard-stature corn (Figure 8).



**Figure 8.** Corteva Agriscience's Boreas wind machine creates winds that can exceed 100 miles per hour to test for standability in corn hybrids.

Another benefit of reduced-stature corn includes the ability to perform later season applications of pesticides and fertilizer with conventional application equipment, not necessarily high-clearance machinery. Most modern applicator machines can clear the reduced-stature corn to make field applications at or after tassel.



**Figure 9.** Field demonstration of reduced-stature and standard-stature corn at mid-vegetative growth stage (top) and near physiological maturity (above) at the Corteva Agriscience research center at Johnston, IA, 2023.

## AGRONOMIC CONSIDERATIONS

Reduced-stature corn brings with it a set of questions often raised by farmers, especially in management and cropping operations. Changes in corn canopy architecture and biomass allocation over the years have come about gradually through decades of corn breeding. Reduced-stature corn represents an abrupt change in multiple plant characteristics. Leaves are shorter and wider and the vertical distance between leaves, as well as the depth of the crop canopy overall, is reduced.

Changes in the architecture of the corn plant could require changes in how those plants are managed.

The first question that often arises with regard to reduced-stature corn is whether reduced-stature corn will require a row-spacing narrower than 30 inches in order to achieve sufficient light interception to maximize yield. The vast majority of corn acres in the U.S. and Canada are currently planted in 30-inch rows. To maximize yield, the crop canopy needs to capture 95% or more of photosynthetically active radiation (PAR) during the critical period immediately before and after silking. Several studies have shown that corn planted in 30-inch rows is generally able to do this in the Midwestern U.S. Research is currently ongoing to determine if row spacings narrower than 30 inches would benefit the yield of reduced-stature corn, or if this can be addressed through breeding and selection.

Another area of interest is the optimal seeding density of reduced-stature corn genetics. Again, the question is raised due to the smaller plant footprint and whether this creates an opportunity to place plants closer together for more yield. Initial work at Corteva Agriscience suggests that seeding densities do not need to be greatly different than similar standard-stature genetics. However, more investigation into this area is needed and research is ongoing.



**Figure 10.** Reduced-stature corn at a density of 40,000 plants/acre in the Corteva Agriscience field demonstration plots at Johnston, IA, July 2023.

Harvestability of reduced-stature corn is often a question raised by farmers. Because the plant is shorter, so is the placement of the ear. Farmers may recall drought years when corn growth development was stunted and perceived difficulty in harvesting the shortened plants and raise similar questions about reduced-stature hybrids. Selection for hybrids that place ears at least 24 inches (60 centimeters) above the ground is important to allow the harvester head to capture the stalk and pull the ear into the harvester.

## SUMMARY

Reduced-stature corn is a new generation of corn genetics that address specific issues around wind lodging and late-season operations. Research and development at Corteva Agriscience is presently being performed to bring the best genetics to farmers' fields and the management guidance for greatest benefit for reduced-stature corn.

# Pollination in Corn: Timeline of Key Steps

Stephen Strachan, Ph.D., Research Agronomist

## KEY POINTS

- One can determine successful ovule fertilization shortly after pollination by gently shaking the ear and estimating the number of detached silks.
- Silks detach from developing, fertilized ovules on the second day after pollination.
- The number of detached silks two days or more after pollination corresponds with the number of kernels on the harvested ear.
- When scouting a field, it is more efficient to observe wilted silks and to feel for reduced silk elasticity to qualitatively estimate pollination success than to harvest ears and estimate the number of detached silks.
- The greater value of harvesting ears and estimating detached silks shortly after pollination is to quantitatively estimate ovule fertilization or to demonstrate the success rate of ovule fertilization to others.

## POLLINATION TIMELINE IN CORN

One method to determine successful ovule fertilization following pollination in corn is to harvest the ear, remove the husk, gently shake the ear, and observe the number of detached silks that fall from the ear (Figure 1). Silks detach from all fertilized ovules while silks remain attached to unfertilized ovules. How soon after fertilization do silks detach from fertilized ovules? A field study was conducted to examine the timeline from pollen shed through ovule fertilization, silk detachment, and eventual kernel set.

## FIELD STUDY

Corn ears were covered before silks emerged. Silks of selected ears were exposed to pollen for one day only on July 17, 18, 19, or 20, the third, fourth, fifth, or sixth day after the field was at 50% silk and the second, third, fourth, or fifth day after the field was at 50% anthesis, respectively. After this single day of exposure, silks were again covered with shoot bags to eliminate further pollination.

Selected ears were harvested at 1, 2, 3, 4, or 5 days after silk exposure to pollen. Husks were carefully removed, the ears were shaken gently to allow detached silks to fall and the number of detached silks per ear were estimated. Pollen density was heavy and silk growth was rapid on July 17 and 18. Pollen density was lighter and silk growth was slower on July 19, and both were dramatically reduced on July 20.



**Figure 1.** Successful pollination can be demonstrated by gently shaking the silks from an ear and estimating the number of detached silks.

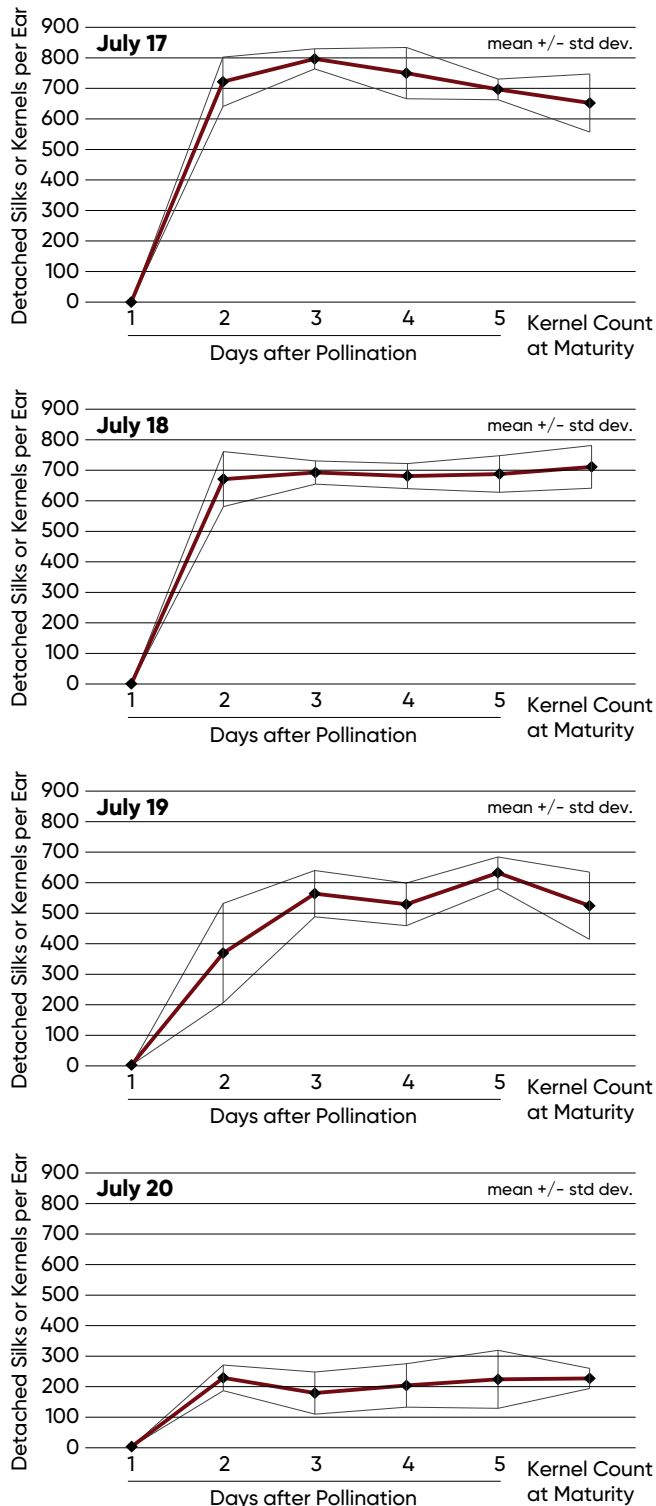
Corresponding ears for each day of exposure were harvested at corn maturity, and the number of kernels on each ear were counted. There was a minimum of six replications for each sample timing for each exposure treatment.

## SILKS DETACH TWO DAYS AFTER POLLINATION

For all four exposure dates, no silks detached the first day after exposure (Figure 2). Silks started to detach the second day after exposure for all four exposure dates. The number of detached silks remained constant (within one standard deviation unit of the mean) at 2, 3, 4, and 5 days after exposure. Kernel counts per ear at maturity corresponded closely to the estimated number of detached silks at 2, 3, 4, and 5 days after exposure. Figure 4 shows representative ears with no silks attached to fertilized, developing kernels at 2 to 5 days after exposure to pollen and kernel set of corresponding ears at maturity. Many silks originating from ovules that were not fertilized during pollination are still attached to the cob at grain maturity.

## TIMELINE: POLLINATION TO SILK DETACHMENT

Results from this study indicate that silks detach from fertilized ovules on the second day after these silks are exposed to pollen. This time interval is consistent with previous research that describes and documents with photomicrographs the growth and development of the corn embryo during the fertilization process (Kiesselbach, 1999).



**Figure 2.** Estimated number of detached silks at 1, 2, 3, 4, and 5 days after pollination and corresponding kernel counts for ears exposed to pollination for one day only at 3, 4, 5, or 6 days after the field was at 50% silk.

Pollen shed starts when mature pollen grains fall through open pores of dehisced anthers. Gravity and wind influence pollen movement as pollen grains fall. If no wind is present, pollen falls at a rate of about 8 inches per second. It would

therefore require just a few seconds for a pollen grain to fall the few feet from the tassel to receptive silks on the same corn plant if the pollen grain fell straight down. The flight time for the vast majority of pollen grains to land on receptive silks would very probably be less than one minute.

Very shortly after pollen grains land on receptive silks, pollen grains start to extrude pollen tubes. Pollen tubes begin to penetrate silk trichomes within about 15 minutes after capturing the fallen pollen. The purpose of the pollen tube is to create a channel within the silk to move the male genetic material from the pollen grain to the receptive female embryo. If corn plants have ample water, pollen tubes complete their growth process within 12 to 18 hours. This time interval depends on where pollen grains land on silks; time intervals increase if pollen tubes must penetrate longer silk lengths. If corn plants are under moisture stress, more than 24 hours may be required to complete pollen tube growth.

After the pollen tube penetrates the embryo sac, one male nucleus fertilizes the egg nucleus to create a fertile zygote that eventually becomes the seed embryo in the mature grain. A second male nucleus fertilizes two polar nuclei to create what eventually becomes the starch in harvested grain. The time required for this double fertilization is not known, but the time interval is probably very short because the male genetic material exits the pollen tube in very close proximity to the female gametes. Kiesselbach showed that a fertilized embryo and the genesis of starch formation are present by 40 hours after pollination.

As soon as the fertile embryo has formed, cells connecting the silk to the embryo sac begin to desiccate. As these cells dry, the silk no longer has access to food and water. The silk detaches from the embryo sac, dries, and turns brown. The point at which this silk detaches creates a silk scar on the mature grain.

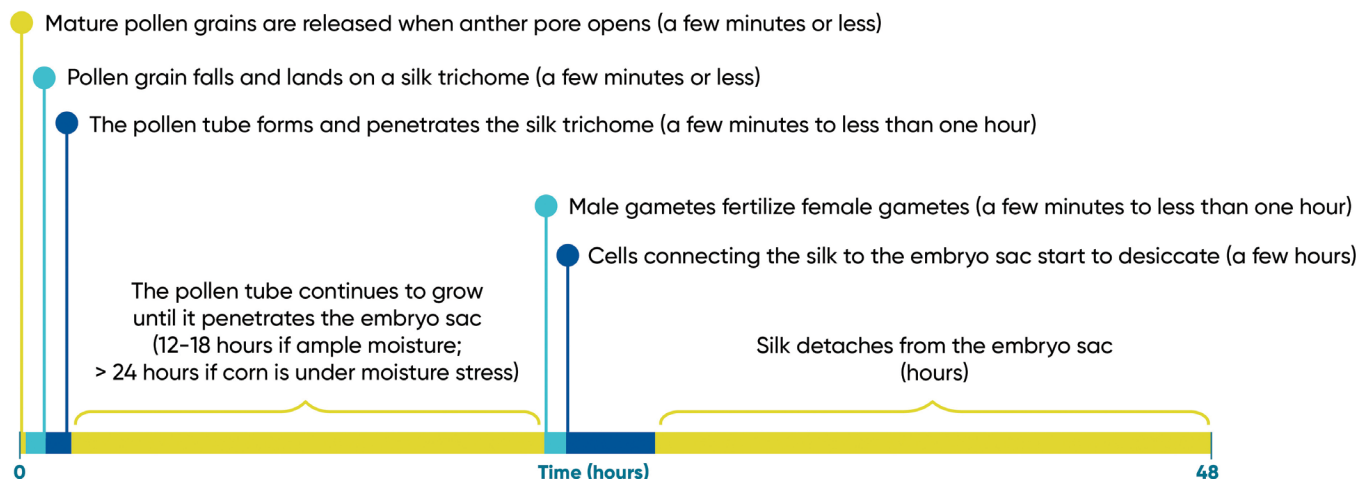


**Figure 3.** Some hybrids have visible scars on the kernels where the silk was attached.

Seeds of some hybrids have visible silk scars while silk scars on seeds of other hybrids are barely visible (Figure 3). This desiccation and silk detachment process does not happen instantaneously. Time must elapse before this process is complete. Apparently, this desiccation and detachment process takes just a few hours because, based on the results of this study, all silks originating from fertilized embryos detach from these fertilized embryos during the second day after pollination. This result is also consistent with Kiesselbach's research. Kiesselbach showed that silk scars are present on the developing seed five days after pollination. Figure 5 briefly summarizes this pollination, fertilization, desiccation, and detachment timeline.



**Figure 4.** Representative ears showing fertilized ovules with no attached silks two or more days after pollination and kernel set at maturity. The field was at 50% silk on July 14. Each date shown in the figure is the single day of silk exposure to available pollen for each treatment date.



**Figure 5.** Timeline for pollination, ovule fertilization, and eventual silk detachment.

### SILK DETACHMENT AS A SCOUTING TECHNIQUE

Silk detachment confirms successful fertilization of the corn embryo and occurs on the second day after pollination of exposed silks. It takes quite a bit of time to harvest an ear, carefully peel back the husks and gently shake the ear to estimate the number of detached silks. From an efficiency perspective, it is faster to estimate fertilization success by observing the turgor of exposed silks. Silks in the early process of detachment or that are recently detached appear wilted and lose some of their elasticity when they are touched. The silk detachment method has value when the observer wants to quantify successful fertilization or the observer desires

to show how far the fertilization process has progressed to another who is less familiar or less knowledgeable of the corn pollination process. In these studies, the number of detached silks two or more days after successful fertilization correlated well with the number of kernels at maturity. The silk detachment method therefore also has value if one wants to estimate the number of potential kernels per ear at harvest.

### Acknowledgment

The author thanks Phil Prybil for supplying the corn hybrid and the land to conduct this study.

# Delayed Pollination Effects on "Zipper Ears" in Corn

Stephen Strachan, Ph.D., Research Agronomist and Mark Jeschke, Ph.D., Agronomy Manager

## KEY POINTS

- Environmental stress to corn during pollination can cause reduced kernel set down one side of a corn ear, a phenomenon commonly referred to as zipper ears.
- Specific factors that contribute to zipper ear formation are not fully understood.
- A field experiment was conducted to try to artificially induce the formation of zipper ears by imposing stress during pollination and selectively delaying pollination along one side of a corn ear.
- When zipper ears occurred, the affected side of the ear corresponded to the side of the ear with delayed pollination.
- Under a higher-stress environment, zipper ear response started to become apparent when pollination was delayed for as little as one day.
- In a corn field, delayed pollination might occur on the bottom side of a silk brush because silks at the top and sides of the silk brush are the first silks to capture limited quantities of falling pollen.

*"Zipper ears are one of the more frequently observed forms of abnormal ear formation."*

## STRESS EFFECTS ON CORN EAR DEVELOPMENT

When corn experiences severe stress during pollination, a common result is incomplete pollination or kernel abortion near the tip of the ear, a phenomenon commonly referred to as tip-back. The silks for the kernels near the tip are the last to emerge, so they can miss pollination if silking is delayed due to stress and will be the first to abort if resources are constrained during grain fill. A less common manifestation of pollination stress is poor pollination or kernel abortion that extends all the way down one side of the ear. This type of ear malformation is often referred to as zipper ears or banana ears, as the ear will often bend in a shape resembling a banana due to the lack of kernels on one side (Figure 1).

Although not necessarily a common occurrence, zipper ears are one of the more frequently observed forms of abnormal ear formation. Most corn growers have likely come across zipper ears at some point. However, the reasons why ears develop in this manner are not fully understood. Poor pollination and/or kernel fill will often occur on the side of the ear angled toward the ground. Differential heating around the circumference of the ear due to differences in sun exposure and physical



**Figure 1.** Corn ear showing aborted kernels down one side of the ear in a zipper ear pattern. Stress at pollination can result in missing kernels, while stress after pollination commonly results in very small or aborted kernels.

obstruction of silks on the underside of the ear by other silks draped over them have both been proposed as possible factors contributing to the formation of zipper ears (Nielsen, 2019).



**Figure 2.** Corn ear showing silks growing along the axis of the ear.

## SILK EXSERTION

Under normal growing conditions, silks emerge from the developing ovule and grow in a straight line along the central axis of the ear (Figure 2). Silk emergence within the silk brush is on the same side of the cob as the ovule to which this silk is attached. In addition, silks exserting from ovules at the base of the ear form the outermost ring of silks in the silk brush. As silks exsert from ovules proceeding toward the tip of the ear, these silks emerge progressively toward the middle of the silk brush. Silks exserting from ovules at the tip of the ear emerge at the center of the silk brush. Any stress or event that inhibits silk growth or inhibits pollination within a specific portion of the silk brush therefore affects an associated specific location of ovules on the corn ear.

## FIELD RESEARCH ON ZIPPER EARS

A field experiment was conducted during the summer of 2021 that sought to better understand factors contributing to the occurrence of zipper ears by artificially inducing their formation. This experiment involved imposing stress during pollination and selectively delaying pollination along one side of a corn ear.

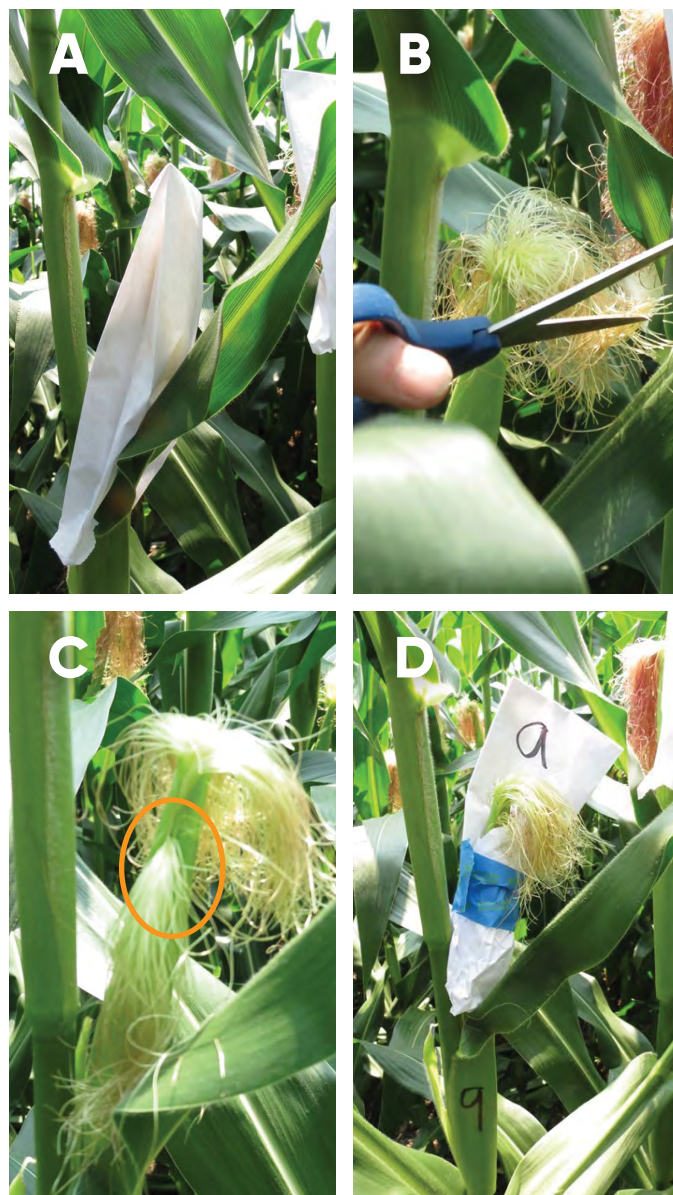
### Delayed Pollination

Silks of ears were covered to inhibit pollination (Figure 3). On the day of exposure, the silk brush was clipped to as length of 1.5 inches (3.8 cm) and a portion of silks was separated from

the silk brush and covered to delay pollination of the selected silks for a specific duration of time. The main portion of the silk brush remained uncovered. The selected, covered silks were uncovered at one, two, three, four, or five days after the main silk brush was uncovered. Silk position around the ear was described as if the circumference of the ear was a clock with the 12 o'clock position being the portion of the ear facing the corn stalk. The 12 o'clock position of the ear was marked when the ear was evaluated at maturity.

### Pollination Stress

This study was conducted in two environments. In the first environment, the corn field received approximately two inches of rain just before pollination started. These corn plants were under very little stress. This environment was labeled as the



**Figure 3.** Illustration of the procedure to delay pollination of selected silks. (A) Silks are covered to inhibit pollination; (B) Silks are clipped to 1.5 inch; (C) A selected portion of clipped silks are separated from the silk brush; (D) The separated portion of silks are covered to prevent pollination.

corn stalk  12 o'clock face  6 o'clock face



1 day delay silk exposure at 12 o'clock position  
**Reduced pollen environment**



3 day delay silk exposure at 3 o'clock position  
**Reduced pollen environment**



5 day delay silk exposure at 6 o'clock position  
**Reduced pollen environment**



3 day delay silk exposure at 6 o'clock position  
**Full pollen environment**

**Figure 4.** Representative ears showing kernel set with responses similar to those of zipper ears at maturity when pollination is delayed on selected silks.

full pollen environment. Weather conditions were the same for the second environment. However, in the second environment, corn plants were detasseled just before pollination. As tassels were pulled, the upper three leaves of corn plants were removed with the tassel. These corn plants were located 7.5 feet from the nearest tassel. Ears developing in this environment were stressed by reduced leaf matter to support sugar production and by reduced pollen densities. This environment was labeled as the reduced pollen environment.

## FIELD RESEARCH RESULTS

When zipper ears occurred, the affected side of the ear corresponded to the side of the ear with delayed pollination. Not all ears with delayed silk exposure expressed reduced kernel set, presumably because it was difficult to completely cover selected silks to fully eliminate exposure to pollen. Zipper ears were much more common in the reduced pollen environment than in the full pollen environment. In the more stressed environment, zipper ear response started to become apparent when pollination was delayed for as little as one day (Figure 4).

## FACTORS CONTRIBUTING TO ZIPPER EARS

In this study, reduced kernel development along one side of the ear occurred more often when plants were growing in the reduced pollen environment. Two stress factors were more

*"Environmental conditions that reduce pollen production and reduce ear growth and vigor increase the risk of zipper ears."*

prevalent in this environment – pollen densities were reduced, due to the spatial separation for tassels shedding pollen and developing silks and ears were under increased nutritional stress, due to the removal of the upper leaves from the plant.

Environmental conditions that reduce pollen production, such as intensive insect feeding on pollen, and environmental conditions that reduce ear growth and vigor, such as drought, heat, cold, or nutrient stress, increase the risk of delayed pollination on one side of the ear which could result in barrenness or the formation of zipper ears on the side of the ear with the delayed pollination.

Delayed pollination was artificially induced in this study. In a corn field, delayed pollination might occur on the bottom side of a silk brush because silks at the top and sides of the silk brush are the first silks to capture limited quantities of falling pollen. Depending on the severity of the stress, zipper ears could begin to form with a pollination delay as short as one day.

## Acknowledgment

The author thanks Phil Prybil for supplying the corn hybrid and the land to conduct this study.



# Corn Brace Roots

Mark Jeschke, Ph.D., Agronomy Manager

## KEY POINTS:

- → Brace roots are nodal roots on corn plants that originate above the soil line.
- → Brace roots play an important role in anchoring and stabilizing the corn plant, as well as water and nutrient uptake.
- → Brace root development is determined by genetics and environment and is linked to growth of the nodal root system and plant growth overall.

## WHAT ARE BRACE ROOTS?

- Roots of the corn plant that grow from nodes above the soil line are commonly referred to as brace roots.
- Brace roots are found on corn, as well as several other grasses such as sugarcane, sorghum, pearl millet, and foxtail millet.
- Despite being a familiar feature of corn plants, the functions of brace roots in supporting plant growth and productivity are not necessarily well understood.
- The name “brace roots” suggests obvious importance in anchoring and stabilizing the plant, but even this function has only recently been conclusively demonstrated by research.

## CORN ROOT SYSTEM

- A corn plant produces two root systems – the seminal root system and the nodal root system.
- The **seminal root system** is comprised of the radicle and up to three pairs of lateral seminal roots. The seminal roots originate from within the seed embryo and sustain the corn seedling for the first couple of weeks after emergence.
- The **nodal roots** are the main root system that sustain the plant through the growing season. Nodal roots develop sequentially from individual nodes above the mesocotyl.
- **Brace roots** are a subset of the nodal roots that originate above the soil line.
- Roots from the first five stem nodes typically emerge below ground with the first four packed tightly together and the first noticeable internode between nodes four and five.
- The first set of brace roots emerges from node 6 (Figure 1), with additional sets of brace roots emerging from node 7 and higher in some cases.
- Brace roots do not always reach the soil, particularly those above node 6. These are referred to as aerial brace roots.



**Figure 1.** Corn plants with brace roots emerged from the 6th node.

## ANCHORING AND STABILITY

- Recent research has shown that brace roots that penetrate the soil do indeed play an important role in stabilizing the plant and reducing horizontal movement due to wind (Reneau et al., 2020).
- In addition to stabilizing the plant, brace roots also help anchor it, protecting against upward uprooting force exerted on the root system (Obayes et al., 2022).
- On plants with more than one node of brace roots that penetrate the soil, the roots from the lower node contribute the most to plant stability because they are anchored more deeply in the soil.

## LODGING RECOVERY

- New brace roots commonly emerge after a lodging event from the side of the stalk facing the soil (Figure 2).
- The exact mechanism that triggers this development is not known; gravitropism (plant response to gravity) could play a role (Sparks, 2023).
- Although it would seem apparent that this response is an adaptation to help the plant stabilize and recover following a lodging event, the extent to which these brace roots actually benefit the lodged plant remains unclear.



**Figure 2.** Newly formed brace roots on a lodged corn plant.

## WHY ARE BRACE ROOTS SOMETIMES STRIPED?

- Pigmentation in brace roots is influenced by hybrid genetics but also expresses in response to sunlight.
- Alternating day/night light exposure as brace roots develop can result in a striped pattern (Figure 3).



**Figure 3.** Anthocyanin pigmentation in brace roots depends on the genetics of the hybrid, but also requires exposure of the brace roots to sunlight.

## WATER AND NUTRIENT UPTAKE

- The role of brace roots in water and nutrient uptake was undetermined until recently.
- Xylem elements – the vascular tissue of plants responsible for water and nutrient transport – are large and numerous in brace roots, suggesting they play an important role in water and nutrient uptake.
- Recent research has shown that brace roots that penetrate the soil do indeed take up water and nitrogen and the larger the roots, the greater the uptake (Rasmussen et al., 2022).



**Figure 4.** Brace root development can be inhibited by excessively wet or dry conditions. Brace roots on this plant have "nubbed off" as a result of extremely hot and dry conditions.

## DO BRACE ROOTS DEVELOP IN RESPONSE TO STRESS?

- It is commonly believed that brace roots in corn develop in response to stress on the plant.
- Brace root development is influenced by genetics and environment. Although brace root development can be influenced by stress conditions, their presence is not necessarily an indicator of stress on the plant (Sparks, 2023.)



© Iowa State University Extension

**Figure 5.** Corn plant with brace roots at node 6 and 7 and new brace roots forming at node 8. Mucilage secreted by the roots is visible on the tips of the aerial brace roots. (Image from Iowa State University Extension and Outreach. Used with permission.)

## WHAT IS THE GOO ON THE ENDS OF BRACE ROOTS?

- Corn root cap cells secrete a gel called mucilage that contains carbohydrates, amino acids, and other compounds.
- This gel plays an important role in forming the interface between the root tissue and soil and interactions with soil microbes.
- Mucilage secreted by brace roots is often visible as droplets that collect at the tips of roots that have not yet reached the soil (Figure 5).
- Recent research has shown that mucilage on aerial brace roots can host nitrogen-fixing bacteria that supply nitrogen to the plant (Van Deynze et al., 2018).



**Figure 6.** Corn plants with no brace root development. This photo was taken in a nitrogen rate study at Johnston, IA in 2012, a year in which extreme drought stress set in very early. The combination of severe drought and nitrogen deficiency stress sharply reduced plant growth.

## WHAT REGULATES BRACE ROOT DEVELOPMENT?

- Corn plants routinely produce brace roots that never reach the soil, which raises the question as to why they do this and whether this is a waste of plant resources that could be more productively allocated to grain production.
- Brace roots are not a discrete system that the plant turns on or off as needed, they are linked to growth of the entire nodal root system and plant growth overall.
- As long as the plant is actively growing, new nodes of brace roots will be produced and brace roots that have penetrated the soil will continue to grow.
- A healthy plant with robust vegetative growth will also tend to set more brace roots.
- It's common for plants along field edges to produce more nodes of brace roots (Figure 7). These plants may also have a second ear and tillers – they can add more growth because they have less competition for resources from other plants.
- In some cases, excessive brace root production may be indicative of some sort of problem that is causing sugars to accumulate in the lower portion of the plant, which the plant then diverts into producing roots.



**Figure 7.** A corn plant on the end of a row with more nodes of brace roots than plants further down the row.

## Brace Roots Gone Wild

- An extreme example of both of these factors can be observed when a corn hybrid adapted for tropical environments is grown in the Corn Belt.
- When outside of their zone of adaptation, these plants will often fail to fill out an ear and will continue adding vegetative growth late into the season, growing extremely tall.
- As the plants continue to grow, they continue to initiate new nodes of brace roots. As many as 12 nodes have been observed on tropical hybrid plants grown at the Corteva Agriscience research station in Johnston, IA (Figure 8).



**Figure 8.** A corn plant with 12 nodes of brace roots. This plant is a 150 CRM hybrid adapted for corn production in Indonesia that was planted in Johnston, IA.

# Ear Declination Prior to Corn Maturity

Mark Jeschke, Ph.D., Agronomy Manager

## KEY FINDINGS

- Ear declination in corn prior to maturity is most commonly associated with late-season drought stress, which causes a loss of cell turgidity and collapse of the ear shank.
- The point of failure in the shank is often severely pinched, which can restrict the flow of sugars into the ear necessary to complete kernel fill.
- If the flow of sugars into the ear drops low enough, it can trigger premature black layer formation and an early end to grain fill.

## DROOPING EARS PRIOR TO CORN MATURITY

- It is common for ears on corn plants to droop downward after physiological maturity and prior to harvest (Figure 1).
- As long as the ear does not drop off the plant, this is not a problem – a downward tilted ear is better able to shed water, which can reduce the risk of ear rots and vivipary (kernels sprouting on the ear) if conditions turn warm and wet prior to harvest.
- However, ear declination prior to black layer is not a good sign. It likely means that the plant has experienced severe late-season stress and grain fill is shutting down.
- The earlier that this occurs in the kernel-filling process, the greater the yield impact is likely to be.



**Figure 1.** It is common for mature ears to tip downward prior to harvest.



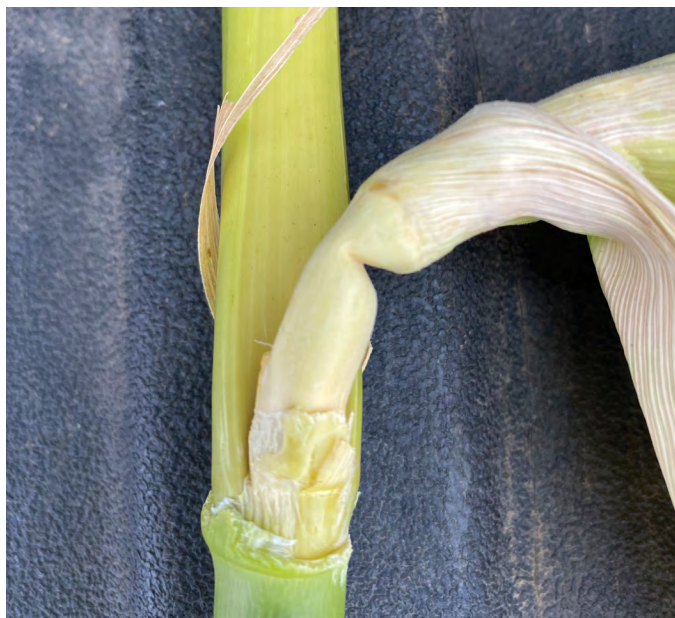
**Figure 2.** Drooping ears on plants that experienced severe late-season heat and drought stress. Ears on these plants were at around 50% milk line, meaning that around 12%-15% of yield would be lost if grain fill ended at this point. Corteva Agriscience Johnston Field Research Center, Johnston, IA. August 30, 2023.

## WHAT CAUSES PREMATURE EAR DECLINATION?

- Ear declination prior to maturity is most commonly associated with late-season drought stress (Figure 2).
- The loss of cell turgidity due to water deficiency in the plant can lead to structural failure in the ear shank.
- Cannibalization of carbohydrates from vegetative tissues can also play a role, as the plant reallocates resources from the stalk and ear shank as it struggles to fill the ear.
- As the shank weakens, it eventually collapses under the force of gravity on the ear.
- The point of failure in the shank is often severely pinched, restricting the flow of carbohydrates into the developing ear (Figure 3).
- Plants with heavier ears are at greater risk of premature ear declination. This can result from favorable conditions during early grain fill – causing the plant to set a large ear – followed by severe late-season stress.



**Figure 3.** Pinched ear shank



**Figure 4.** Close-up of a pinched ear shank on a plant that experienced severe late-season drought stress resulting in ear declination prior to physiological maturity. The pinched shank restricts the flow of sugars into the developing ear. Johnston, IA. August 30, 2023.

## RISK OF EAR DROP

- A weakened ear shank can increase the risk of ear drop prior to harvest.
- Fields with ear declination prior to maturity should be monitored ahead of harvest so they can be prioritized if ear drop starts to occur.



**Figure 6.** Severe late-season stress can weaken stalks and ear shanks as the plants remobilize carbohydrates to fill the ear.

## RESTRICTED FLOW OF SUGARS TO THE EAR

- Once the ear droops, the pinched ear shank can restrict the flow of sugars into the ear. If the flow drops low enough, it triggers premature black layer formation and an early end to grain fill (Figure 4).
- Black layer formation is related to the ability of plants to maintain a continuous sucrose supply to developing kernels. Any disruption of this supply that causes the flow of sucrose to drop below a minimum threshold can trigger early black layer formation.
- The yield impact of early grain fill termination depends on the kernel fill stage when it occurs (Figure 5).

### STAGE R5

*Beginning Dent*

**Grain Moist: 50%-55%**

**~400 GDUs** remaining to maturity

*Yield loss from killing frost at this stage: 35%-40%*



### STAGE R5.25

*1/4 Milk Line*

**Grain Moist: 45%-50%**

**~300 GDUs** remaining to maturity

*Yield loss from killing frost at this stage: 25%-30%*



### STAGE R5.5

*1/2 Milk Line*

**Grain Moist: 40%-45%**

**~200 GDUs** remaining to maturity

*Yield loss from killing frost at this stage: 12%-15%*



### STAGE R5.75

*3/4 Milk Line*

**Grain Moist: 35%-40%**

**~100 GDUs** remaining to maturity

*Yield loss from killing frost at this stage: 5%-6%*



### STAGE R6

*Physiological Maturity*

**Grain Moist: 30%-35%**

**0 GDUs** remaining to maturity

*Yield loss from killing frost at this stage: 0%*



**Figure 5.** Estimated yield loss associated with termination of grain fill prior to physiological maturity.

# Kernel Weight Differences by Hybrid in Iowa

Ryan Van Roekel, Ph.D., Former Field Agronomist; Dennis Holland, Product Agronomist; Alex Woodall, Field Agronomist; Bill Long, Field Agronomist; Matt Vandelaar, Field Agronomist; Nate LeVan, Field Agronomist; Jason Kienast, Sales Representative; Lucas Borrás, Ph.D., Research Scientist; and Kurt Eischeid, Field Agronomist

## KEY FINDINGS

- → Kernel weight is a key component of grain yield that can vary by hybrid and be affected by environmental conditions and management practices.
- → A 7-year field study found that kernel weight can vary widely due to differences in growing conditions (from 52,000 to 137,000 kernels/bu) but that certain hybrid families consistently have higher or lower kernel weights than average.
- → These estimates for kernel weight by hybrid family can be useful for yield estimation, management decisions, and diagnosing yield results differing from expectations.

## BACKGROUND

- Corn grain yield is related to the number of kernels per acre and the weight of those kernels.
- Kernel number is generally regarded as the most important component in determining yield and the most responsive component to environment and management.
- However, large variations in observed kernel weights suggest that this yield component can also have a large effect on yield.
- Kernel weight is considered a heritable trait and is known to vary between hybrid families.
- Kernel weight at harvest can be affected by the crop's ability to set a high potential kernel weight in the weeks immediately following silking, and its capacity to reach that potential during the grain fill period.
- Corn has a limited ability to increase kernel weights once the potential has been set (unlike soybean), so it is important to maximize potential kernel weight.
- To achieve big kernels at harvest, favorable management and conditions are required within the first 20 days after silking in order to set a large potential kernel weight, followed by favorable conditions during grain fill that will allow the corn to reach that full potential.
- When late season stresses occur, corn is very sensitive to grain fill stress due to its relatively limited ability to remobilize resources to fill kernels compared to other crops like soybean and wheat.
- As such, it is common for a late season drought or nutrient deficiency to reduce kernel weights at harvest, even for hybrids that normally have large kernels or when conditions were favorable to set a high kernel weight potential soon after pollination.

## YIELD ESTIMATION CONSIDERATIONS

- Corn grain yield can be estimated in-field based on estimates of yield components: ears per acre, kernels per ear, and kernel weight.
- The first two components are relatively straightforward to estimate – conducting several stand counts of 1/1000th of an acre can provide an estimate of ears per acre and kernel counts can be used to estimate kernels per ear.
- Furthermore, new technology has greatly improved the speed and accuracy of estimating ears per acre:
  - » UAV imagery powered by Drone Deploy can provide field-wide stand counts.
  - » The Vegetation Index from satellite imagery in Granular Insights can be used to guide sampling according to field variability to get a better estimate of whole-field yield.
- However, estimating the third yield component, kernel weight, remains challenging.
- A common practice is to assume 90,000 kernels/bushel, but this practice often underestimates yield and does not consider differences among hybrids or environments.
- While work is underway to develop a more reliable way to estimate kernel weights, research was undertaken to characterize common hybrid families in local plots to provide an estimate as to how genetics influence kernel weights under normal management to provide more accurate yield estimates.
- Additionally, knowing a hybrid's expected kernel weight can help with understanding the yield impact of late-season management or environmental issues that may prevent a hybrid from reaching its normal kernel weight.



**Figure 1.** Representative kernels from the middle of an ear from hybrid families with above-average (P1197) and below-average (P1082) kernel weight. Photo courtesy of Bill Long in 2019.



## STUDY DESCRIPTION

- Kernel weight data was collected from a selection of plots across Iowa from 2016-2022.
- Kernel weights for each hybrid at a location were measured in one of two ways:
  - » A subsample of 100 random kernels, or more, were weighed and corrected to 15% moisture.
  - » Multiple stand, ear, and kernel counts were performed prior to harvest to provide a reasonably accurate estimate of ears per acre and kernels per ear. This data was divided by the hybrid's yield at 15% to determine kernels per bushel.
- Both methods have limitations but hybrid trends were consistent and the datasets were combined to increase the number of locations.
- A location average kernel weight was calculated from the average of all hybrids at each plot location.
- To account for environmental differences between locations, a relative kernel weight for each hybrid within a location was calculated as a percentage of the location average. Those percentages were then averaged by hybrid family over all plot locations, as shown in Table 1.
- The standardized kernels per bushel in Table 1 were calculated as 80,000 kernels/bu divided by the relative kernel weight percentage to provide a reasonable estimate for kernels/bu by hybrid family. This value is not the actual mean of the observed kernels/bu because the dataset is unbalanced for locations between hybrids. As such, caution should be used with these results.

## RESULTS

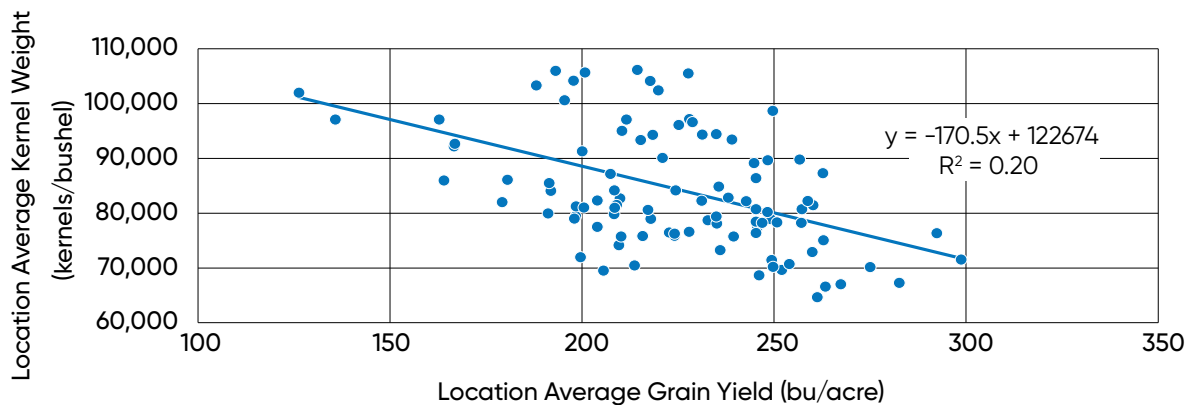
- Kernel weight (kernels/bu) was found to vary widely by hybrid, location and yield level.
- The grand mean of all kernel weight observations was 83,588 kernels/bu, but ranged from 52,192 to 136,518 kernels/bu. Grain yield averaged 224.6 bu/ac with a range from 116.2 to 317.0 bu/acre.
- Individual hybrids also had a wide range in kernel weights between locations. For example, the P1197 family ranged from a high of 54,656 kernels/bu down to 115,749 kernels/bu. However, across all locations, its kernel weight averaged 105.7% of the location average.
- On average, there was a trend for higher yields to be associated with higher kernel weights (Figure 2).

**Table 1.** Kernel weight as a percentage and standardized kernels/bu by hybrid family.

Hybrid Family	Relative Kernel Weight (% of Loc. Mean) <sup>1</sup>	Standardized Kernels per Bushel <sup>2</sup>	# Loc.
P9492	91.0	88,000	4
P9823	98.7	81,000	13
P9955	101.5	79,000	9
P0075	101.9	78,500	44
P0220	102.6	78,000	44
P0339	105.5	76,000	47
P0404	102.4	78,000	19
P0421	104.6	76,500	45
P0529	95.9	83,500	14
P0589	103.4	77,500	43
P0622	102.2	78,500	51
P0688	94.5	84,500	56
P0720	104.2	77,000	9
P0859	99.6	80,500	19
P0924	103.8	77,000	28
P0953	102.1	78,500	38
P0977	102.8	78,000	30
P0995	98.4	81,500	10
P1027	101.0	79,000	16
P1082	97.8	82,000	59
P1093	90.1	89,000	62
P1108	101.8	78,500	31
P1164	97.6	82,000	20
P1170	98.5	81,000	7
P1185	96.6	83,000	72
P1197	105.7	75,500	61
P1213	103.5	77,500	26
P1222	101.0	79,000	17
P1244	95.1	84,000	24
P1353	97.1	82,500	31
P1359	103.8	77,000	13
P1366	96.1	83,000	93
P1380	100.9	79,500	18
P1413	99.6	80,500	8
P1563	97.4	82,000	17
P1587	109.3	73,000	18
P1608	101.9	78,500	8
P1742	105.9	75,500	8

<sup>1</sup>Calculated as hybrid kernels per bushel compared to the location average kernels per bushel, then averaged over all locations.

<sup>2</sup>Calculated as the kernel weight percentage applied to a "normal" value of 80,000 kernels per bushel, rounded to the nearest 500.



**Figure 2.** Kernel weight as compared to grain yield on average by location.

## DISCUSSION

- o With the wide variation in observed kernel weights between hybrids and locations, it is important to exercise caution when using the standardized kernels/bu shown in Table 1.
  - » Environmental and management factors can and will greatly influence a hybrid’s ability to maintain its grain fill and express its full kernel weight potential.
    - For example, the location average kernel weight in 2020 was 85,962 kernels/bu due to late-season drought conditions compared to 2019 at 76,950 kernels/bu with more favorable weather.
  - » Often issues like drought, disease pressure, or nitrogen deficiencies can hinder late season plant health and limit a hybrid’s grain fill period and resulting kernel weight.
  - » When ignoring hybrid interactions and comparing location average kernels/bu to average yield, a correlation was observed where higher yield plots had higher kernel weights (Figure 2).
  - » The variation in kernel weight compared to yield could be due to the size of the potential kernel weight determined soon after pollination, or the fulfillment of that potential later in grain fill.
    - For example, there is a wide range in average kernel weights for plots that had an average yield near 200 bu/acre.
    - The 200 bu/acre plots with 70,000 kernels/bu were likely near their maximum potential kernel weight, while plots with 105,000 kernels/bu likely had late season stress that prevented them from living up to their potential.
    - Within each of these plots, some hybrids had differing trends for maintaining kernel weight with stress or increasing kernel weight with more favorable conditions, likely by setting a higher potential kernel weight.
  - » Future work will attempt to document potential kernel weights and then observe their fulfillment by hybrid in differing locations.
- o It is important to note that high kernel weights are not always required for high yields, especially for some hybrids.
  - » P1366 is an example of a hybrid family with below average kernel weight that is capable of very high yields (up to 313.9 bu/acre in this study).
  - » P1366 tends to achieve high yields through kernel number (more rows around and/or ear length) vs hybrid families like P1197, which tends to have kernel numbers closer to average but high kernel weights.
- o Also note that kernel weight is not correlated with test weight. Test weight is the weight of a volumetric bushel, while kernel weight is a measure of how many kernels are in a 56 lb bushel.
  - » An example of this distinction is the P1093 hybrid family, which has very high test weight with excellent grain quality, but its high-density kernels tend to be smaller in size and thus weigh less per kernel.
- o When estimating yields, it is best to stick with an average kernel weight estimate of 80,000 kernels/bu for most hybrids.
  - » Consider using a lower kernels/bu (i.e., 75,000) for hybrid families like P1197 & P1587 and higher kernels/bu (i.e., 90,000) for hybrid families like P9492 & P1093.
  - » If late-season growing conditions are excellent, using a factor of 70,000 kernels/bu may be more appropriate.
  - » Conversely, if late-season conditions are poor, a factor of 100,000 kernels/bu might be more accurate.
  - » Be sure to get multiple accurate estimates of kernels/ear and ears/acre to avoid overestimating yield.

## CONCLUSIONS

- o Kernel weight is a key component of corn grain yield that varies greatly by hybrid and environment.
- o Having an idea of a hybrid’s normal kernel weight can be useful for more accurate yield estimates.
- o This knowledge also helps provide an understanding of how a hybrid makes its yield (kernel number vs kernel weight), which can be useful when making management decisions or when diagnosing yield results that differ from expectations.



# Asiatic Garden Beetle

Mark Jeschke, Ph.D., Agronomy Manager

## KEY POINTS:

- → Asiatic garden beetle (*Maladera castanea*) has historically been a sporadic pest of field crops but has recently become a more frequent pest of corn and soybean.
- → Crop injury in corn and soybean is primarily the result of larval root feeding. Root damage can cause stunting and discoloration of plants and can kill plants if severe enough.
- → A high-rate insecticide seed treatment used in combination with liquid bifenthrin applied at planting appears to be the best option for protection in corn.

## DISTRIBUTION AND PEST STATUS

- Asiatic garden beetle (*Maladera castanea*) is a non-native species in North America that was introduced to the northeast U.S. from Japan in the 1920s.
- Following its initial introduction, populations have spread throughout the Northeastern U.S. and parts of Eastern Canada, westward – as far as Kansas and Missouri, and southward – as far as Georgia and Alabama (Skelley, 2013).
- Asiatic garden beetle has historically been a sporadic pest of field crops; however, it has recently become a more frequent pest of corn and soybean in Indiana, Michigan, and Ohio.



**Figure 1.** Asiatic garden beetle feeding may be scattered across a field, but the most severe damage is often concentrated in areas of intensive egg laying or better survival of larvae, commonly in sandy spots. Damage may be compounded by other factors affecting plant vigor.

## HOST RANGE

- Asiatic garden beetle has a wide host range – over 100 hosts are known, consisting primarily of perennial ornamentals.
- It has historically been a pest of ornamentals and turf grass but can also damage vegetables and row crops, including corn, soybeans, and wheat.
- Asiatic garden beetle is also known to feed on several common weed species, including marestail, giant ragweed, chickweed, purple deadnettle, pokeweed, and Virginia creeper (DiFonzo, 2018; Pekarcik, 2018).

## LIFECYCLE

- Asiatic garden beetle undergoes one generation per year with four stages: egg, larva, pupa, and adult.
- They overwinter in the soil as small grubs, which feed on the roots of grasses and weeds in early spring.
- Larvae typically pupate in late May and June and emerge as adults in late June and July. Females burrow into the soil to lay their eggs, which hatch in about two weeks.



**Figure 2.** Asiatic garden beetle larva (left) with arrow indicating the enlarged maxillary palps, and adults (right). Beetle photo provided courtesy of David Shetlar, Ohio State University.)

## IDENTIFICATION

- Larvae are up to ½ inch long and can be identified most easily by the enlarged maxillary palps just behind the mouth parts. These are light-colored fleshy appendages that appear to be in constant motion (Figure 2).
- Asiatic garden beetle larvae also have a characteristic anal slit and semi-circular raster pattern under the tail.
- Adults are scarab-shaped, tan- or cinnamon-brown-colored beetles with a slight iridescent sheen. They are slightly smaller than Japanese beetles (about 5/16 to 3/8 inch in length).



## INJURY SYMPTOMS AND IMPACT ON CROP

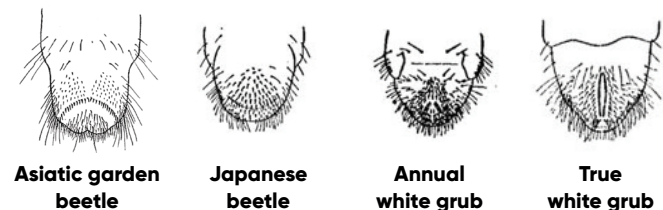
- Crop injury in corn and soybean is primarily the result of larval root feeding. Symptoms closely resemble root feeding by other grub pests including annual and biennial white grubs and Japanese beetles in the spring.
- Larval feeding removes root hairs and may damage the mesocotyl between the seed and the main root system of corn. This reduces early vigor until the affected plants can regrow an adequate root system.
- Root damage can cause stunting and discoloration of plants and can kill plants if severe enough. Stand losses of over 40% have been observed in corn (Pecarcik, 2018).
- Stand reduction in soybean can be less noticeable due to the greater number of plants/acre compared to corn.
- Aboveground symptoms are often not visible until feeding has already been underway for several days.
- Heavy infestations are most common in sandy soils.
- Adult feeding is rarely a problem in row crops but may be noticeable on nearby vegetable or ornamental foliage as feeding on the leaves (especially at night and particularly around the leaf edges).



**Figure 3.** Root damage on corn and soybean seedlings caused by Asiatic garden beetle feeding in Indiana in 2018. (Photos by Lance Shepherd, Pioneer Field Agronomist.)

## RELATED OR OFTEN MISIDENTIFIED GRUBS

- Manure scarabs – generally smaller size, found associated with pastures or manure.
- Annual, biennial grubs and Japanese beetle – generally over ½ inch in length with a different raster pattern and no maxillary palps. Asiatic garden beetle grubs are smaller and generally more active than these other common grubs.



**Figure 4.** Raster patterns of Asiatic garden beetle and other grubs common to field crops.

## MANAGEMENT CONSIDERATIONS

### Trapping

- Limited success of identifying elevated grub numbers prior to planting has been made with wireworm bait stations.
- Adult populations have also been monitored with immersion-type western bean cutworm traps.

### Scouting

- Scouting for Asiatic garden beetle larvae prior to planting to identify fields at risk of damage provides the only real opportunity to protect the crop by including an insecticide at planting (MacKellar and DiFonzo, 2018).
  - » Prior to spring tillage, dig around any alternate weed hosts that are present in the field such as marehail or giant ragweed to look for larvae.
  - » Check freshly tilled soil during tillage operations for larvae, particularly if there are a lot of birds feeding in the tilled soil.
- Scout for Asiatic garden beetle larvae in corn by digging around plants in the field during the early vegetative growth stages to look for signs of root feeding or presence of larvae.
  - » Focus scouting on plants that appear to be suffering some sort of stress. Damaged plants often appear stunted and purplish.
  - » Asiatic garden beetle has historically been most prevalent in fields with sandy soil; however, feeding injury has become more common in loamy and heavier soils.
  - » Damage often occurs in irregular patches.
  - » Root feeding ceases when larvae enter the pupal stage, typically around the end of May. Later-planted fields generally have a lower risk of root feeding damage.
- Asiatic garden beetle adults are active from June through September. They are nocturnal and attracted to outdoor lights and feed on nearby foliage. Monitor these locations to get a sense of relative population levels in an area.



### Favorable Conditions

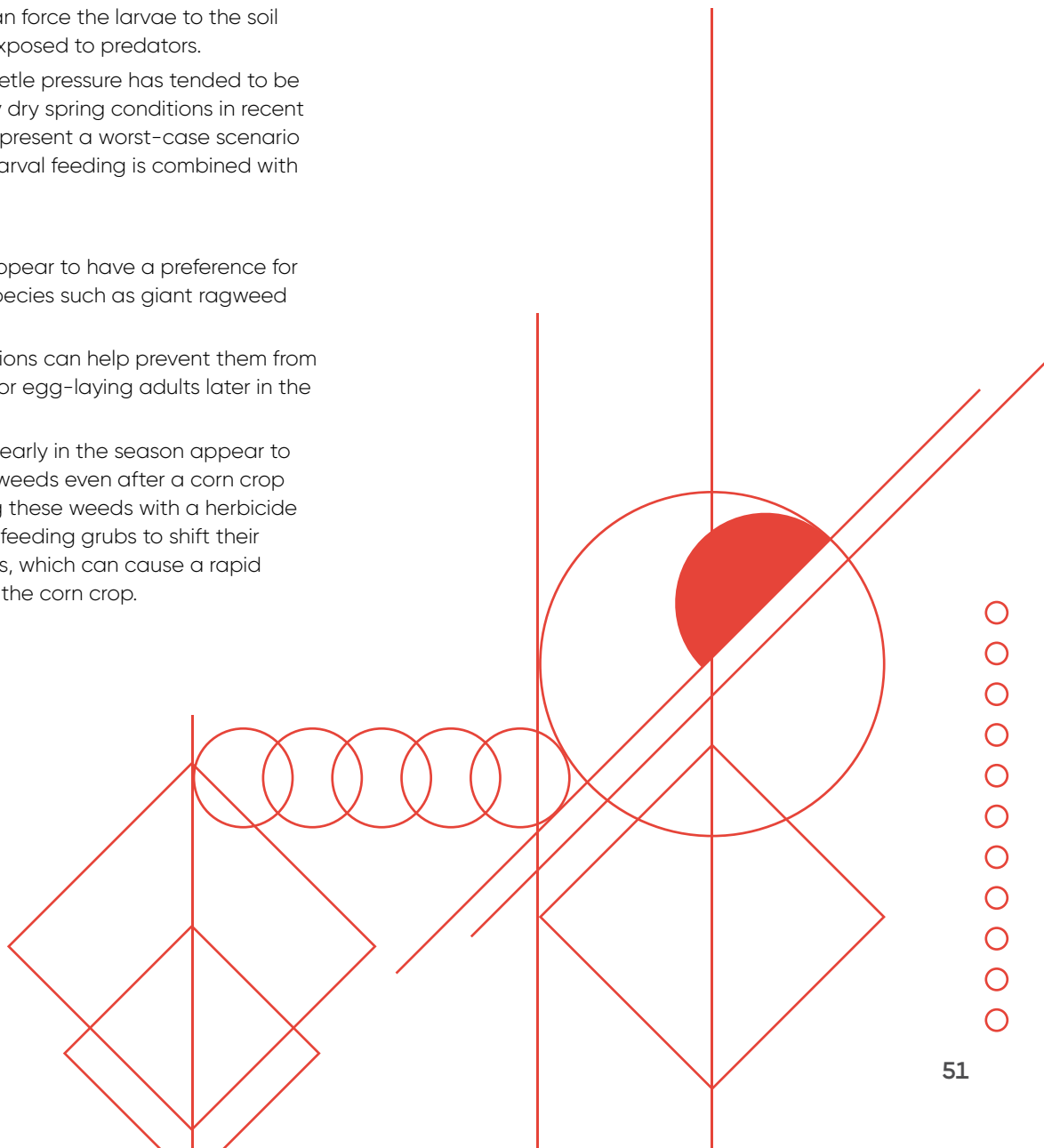
- Soil disturbance may promote larval mortality and predation to a low degree; thus, no-till may be conducive to higher survival.
- Soil saturation in spring tends to increase mortality, similar to corn rootworm, and can force the larvae to the soil surface where they are exposed to predators.
- Higher Asiatic garden beetle pressure has tended to be associated with relatively dry spring conditions in recent years. A dry spring could present a worst-case scenario for crop damage where larval feeding is combined with poor root development.

### Weed Management

- Asiatic garden beetles appear to have a preference for several common weed species such as giant ragweed and marestail.
- Managing weed populations can help prevent them from acting as an attractant for egg-laying adults later in the growing season.
- Grubs feeding on weeds early in the season appear to continue feeding on the weeds even after a corn crop is established. Controlling these weeds with a herbicide application will force the feeding grubs to shift their feeding to the corn plants, which can cause a rapid escalation in damage to the corn crop.

### Insecticides

- Insecticide seed treatments are the most widely used form of protection against larval feeding in corn; however, high rates are needed for higher populations, and they may not provide complete protection.
- A FIFRA 2(ee) recommendation is in place for Bifenture® LFC and Capture® LFR® on Asiatic garden beetle at a rate of 8.5 oz/acre. Always read and follow product label guidelines.
- Best results for protection against high Asiatic garden beetle feeding pressure have been reported with a high-rate insecticide seed treatment used in combination with liquid bifenthrin applied at planting.
- Pioneer® brand corn products are available with an enhanced CRW package with a 1250 rate of Lumisure™ insecticide seed treatment.
- Later-planted fields generally have a lower risk of root feeding damage from Asiatic garden beetle, so may be less likely to benefit from an insecticide application.



# Corn Rootworm Management Using RNAi

Mark Jeschke, Ph.D., Agronomy Manager

- RNA interference (RNAi) technology provides a new mode of action for protection against corn rootworm.
- RNAi is a mechanism in cells that regulates gene expression by reducing or “silencing” the activity of specific genes.
- RNAi technology protects against corn rootworm by silencing the Snf7 gene, a gene in the corn rootworm genome that codes for a protein necessary for its survival.
- Vorceed™ Enlist® corn contains three modes of action for protection against corn rootworm: two Bt traits (Cry3Bb1 and Cry34/35Ab1) and RNAi (DvSnf7).
- Field trials showed that the addition of DvSnf7 dsRNA to corn hybrids with Cry3Bb1 and Cry34/35Ab1 Bt traits significantly reduced root damage and adult emergence in field with high rootworm pressure.

*“The RNAi gene-silencing mechanism was first discovered in 1998; a discovery that was awarded a Nobel Prize.”*

## CORN ROOTWORM MANAGEMENT

Corn rootworm has long been one of the most damaging insect pests of corn in North America. There are four rootworm species that affect corn: western corn rootworm (*Diabrotica virgifera virgifera*), northern corn rootworm (*D. barberi*), Mexican corn rootworm (*D. virgifera zea*), and southern corn rootworm (*D. undecimpunctata howardi*). Of these four species, the western and northern corn rootworm are the most economically important and the most challenging to control.

Western and northern corn rootworms have a history of adapting to and overcoming control practices, which has increased the complexity and difficulty of successfully managing these pests.

**Crop Rotation:** Historically, crop rotation was an effective and widely used management strategy, and it is still a very important part of an integrated management strategy; however, populations of both western and northern corn rootworm have developed the ability to survive in two-year corn-soybean rotations.

**Insecticides:** Western corn rootworms have shown resistance to several classes of insecticides, including both soil applications for larva control and foliar applications for adult control.

**Bt Traits:** Bt corn hybrids engineered to express genes from the common soil bacterium *Bacillus thuringiensis* have been an important management tool for corn rootworm for the past 20 years. However, field-evolved resistance in western corn rootworm has now been documented for all four Bt traits for corn rootworm protection currently on the market (Table 1).

Cross-resistance between the Cry3 proteins (Cry3Bb1, mCry3A, and eCry3.1Ab) has been demonstrated, which means that the four current Bt traits only provide two effective modes of action against western corn rootworm (Jakka et al., 2016).

**Table 1.** Bt technologies currently on the market for protection against corn rootworm and year that field-evolved resistance in western corn rootworm was first documented.

Bt Protein	Original Commercial Name	First Case of Field-Evolved Resistance
Cry3Bb1	YieldGard® Rootworm	2011 <sup>a</sup>
Cry34/35Ab1	Herculex® RW	2013 <sup>b</sup>
mCry3A	Agrisure® RW	2014 <sup>c</sup>
eCry3.1Ab	Agrisure Duracade®	2016 <sup>d</sup>

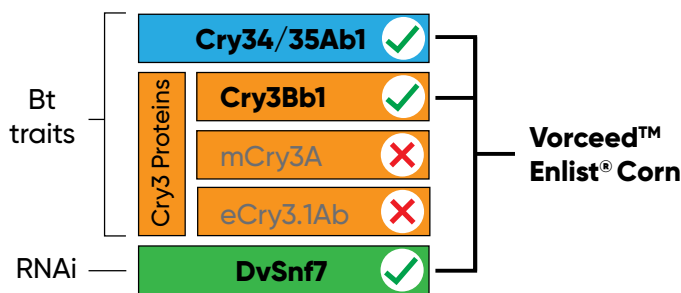
<sup>a</sup>Gassmann et al., 2011; <sup>b</sup>Gassmann et al., 2016; <sup>c</sup>Gassmann et al., 2014; <sup>d</sup>Zukoff et al., 2016

## A NEW ROOTWORM MANAGEMENT TOOL

The destructiveness of western corn rootworm in corn and its continuing ability to overcome management tactics has created an urgent need for additional management tools. Ribonucleic acid interference (RNAi) technology has been commercialized to provide an additional unique mode of action for protection against corn rootworm. The



first transgenic corn product with an RNAi-based plant incorporated protectant for corn rootworm management was registered by the U.S. EPA in 2017. This product includes two Bt traits (Cry3Bb1 and Cry 34/35Ab1) plus RNAi to provide a total of three effective modes of action against corn rootworm. This combination of three modes of action is available in Corteva Agriscience seed brands as Vorceed™ Enlist® corn.



**Figure 1.** Vorceed Enlist corn contains three modes of action for protection against corn rootworm: two Bt traits (Cry3Bb1 and Cry34/35Ab1) and RNAi (DvSnf7).

## RNA INTERFERENCE (RNAi)

### What is RNAi?

RNA interference (RNAi) is a mechanism in cells that regulates gene expression by reducing or “silencing” the activity of specific genes. It does this by using small RNA molecules called siRNAs (short interfering RNAs) to target and degrade the messenger RNA (mRNA) molecules that code for the gene of interest. The RNAi mechanism is found in many organisms, from plants and animals to fungi and bacteria.

RNAi is thought to have evolved as a defense mechanism against invasive genetic elements such as RNA viruses and transposable elements (mobile DNA sequences that can replicate and insert themselves into different locations within the host genome, also known as “jumping genes”). The RNAi gene-silencing mechanism was

“An ideal RNAi target gene is one that is involved in a critical physiological process in the insect pest.”

first discovered in the roundworm *Caenorhabditis elegans* in 1998 (Fire et al., 1998); a discovery that was awarded a Nobel Prize in 2006.

The potential utility of RNAi as a mechanism to protect corn against corn rootworm was first demonstrated in 2007 (Baum et al., 2007).

**How does RNAi work?**

The process of RNA interference starts with the production of double-stranded RNA (dsRNA) molecules that match the sequence of the target gene (Figure 2). These dsRNA molecules are recognized by an enzyme that cuts them into short pieces (siRNAs). The siRNAs are then loaded onto a protein complex called the RNA-induced silencing complex (RISC).

Once the RISC is loaded with the siRNAs, it can search the cell for mRNAs that have a complementary sequence to the siRNAs. When the RISC complex finds an mRNA molecule that matches the siRNA, it cleaves the mRNA, leading to its degradation. This prevents the mRNA from being translated into a protein, effectively silencing the gene.

○ *“The RNAi-based mode of action generally is slower to kill corn rootworm larvae than Bt proteins due to the multistep process involved in RNAi uptake, gene suppression, and systemic spread.”*

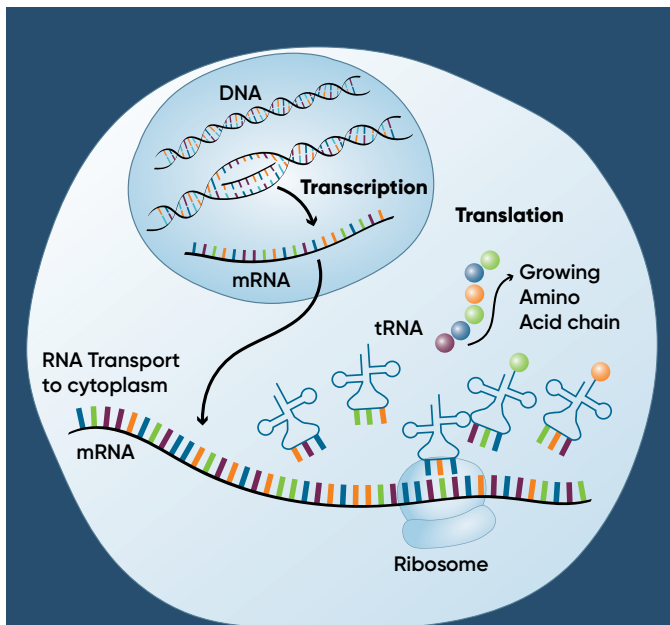
**RNAI-BASED CORN ROOTWORM CONTROL**

The RNAi technology in Vorceed™ Enlist® corn protects against corn rootworm by silencing the Snf7 gene, a gene in the corn rootworm genome that codes for a protein necessary for its survival. Snf7 is one of several RNAi target genes that has been evaluated for control of corn rootworm. An ideal RNAi target gene is one that is involved in a critical physiological process in the insect pest – so that silencing it will lead to insect mortality – and one for which the dsRNA expressed by the crop does not affect non-target organisms.

Gene silencing via the RNAi pathway involved three steps: dsRNA uptake, gene silencing, and systemic spread.

**Uptake:** A gene is inserted into the corn genome that codes for a corn rootworm Snf7 homolog (DvSnf7). When this DNA is transcribed in the corn plant, the resulting RNA folds onto itself forming dsRNA. The DvSnf7 dsRNA is ingested by corn rootworm larvae when they feed on the corn roots.

**Gene Silencing:** The dsRNA is cleaved into siRNAs, which are then loaded onto the RISC. The RISC then targets Snf7 mRNA molecules, binds to them, and cuts them up; effectively silencing the gene by preventing the mRNA from being translated into a protein. Since the corn rootworm needs this protein to survive, deprivation eventually leads to larval death.



There are two primary processes involved in producing proteins from genetic information coded in DNA: transcription and translation.

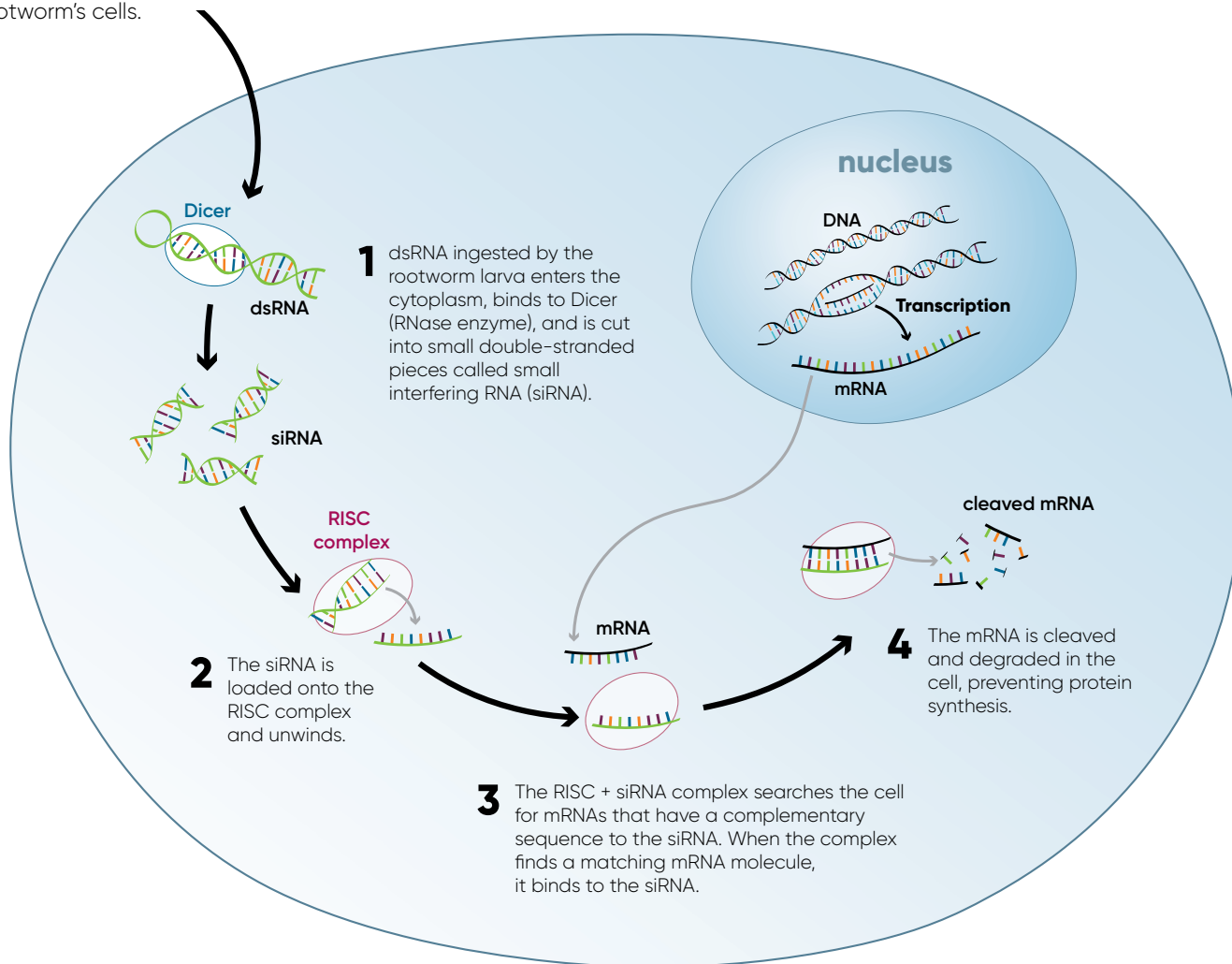
**Transcription** is the process by which genetic information stored in DNA is used to produce a complementary messenger RNA (mRNA) molecule. It occurs in the nucleus of eukaryotic cells.

**Translation** is the process by which the genetic information carried by mRNA is decoded to produce a specific sequence of amino acids, which form a protein. It occurs in the cytoplasm of all cells.

RNAi is a form of **post-transcriptional gene silencing (PTGS)**, which refers to regulation of gene expression that occurs after transcription has taken place and involves the degradation or inhibition of mRNA.



Once ingested, the dsRNA initiates the RNAi process in the rootworm's cells.



**Figure 2.** Diagram showing the key steps in the RNAi pathway in a corn rootworm cell. dsRNA produced by the corn plant and ingested by the corn rootworm initiates the RNAi process in the rootworm's cells, blocking production of a key protein essential for the rootworm's survival.

**Systemic Spread:** Following ingestion by a corn rootworm larva, the dsRNA moves beyond the gut of the insect and spreads systemically throughout the body. This systemic spread is crucial in achieving sufficient gene silencing to kill the larva.

## EFFICACY OF CORN ROOTWORM CONTROL

The RNAi technology in Vorceed™ Enlist® corn is active against all four corn rootworm species that impact corn in North America: western, northern, southern, and Mexican corn rootworm. As with Bt proteins, RNAi-based modes of action require corn rootworm larvae to feed on roots and ingest root tissue to be exposed to the insecticidal dsRNA.

RNAi can result in insect mortality comparable to that of a Bt protein; however, the RNAi-based mode of action generally is slower to kill corn rootworm larvae than Bt proteins due to the multistep process involved in RNAi uptake, gene suppression,

and systemic spread. If it were used alone and not stacked with Bt traits, RNAi would significantly reduce the emerging adult rootworm population but would not provide adequate root protection due to the longer time to mortality. Because of this – as well as the need to promote trait durability – DvSnf7 is not marketed as a single trait product and is only available in combination with at least one Bt trait.

Field trials showed that the addition of DvSnf7 dsRNA to corn hybrids with Cry3Bb1 and Cry34/35Ab1 Bt traits significantly reduced root damage in fields with high western corn rootworm densities compared to corn with only the Bt traits (Head et al., 2017). The addition of DvSnf7 dsRNA to Bt hybrids was also effective in reducing western corn rootworm adult emergence. DvSnf7 dsRNA is expressed throughout the corn plant – including plant tissues commonly fed upon by corn rootworm adults. However, concentrations are not high enough to cause mortality in adults.

# Field Performance of Vorceed™ Enlist® Corn Rootworm Traits

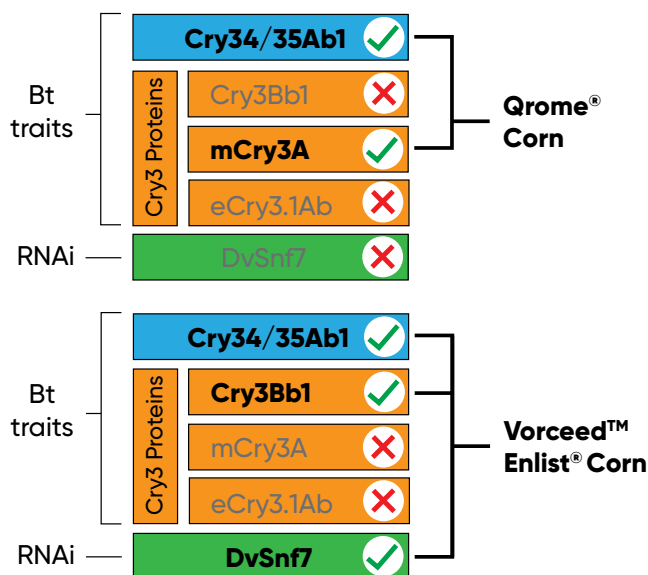
Jim Bing, Program Leader – Insect Control Traits; Tim Nowatzki, Senior Research Scientist; Tim Mabry, Field Scientist; Jeff Klever, Staff Associate Investigator; and Mark Jeschke, Ph.D., Agronomy Manager

## KEY FINDINGS

- The corn rootworm traits in Qrome® corn and Vorceed™ Enlist® corn both provided effective control of corn rootworm larval feeding.
- The Vorceed Enlist traits provided a significant advantage at locations with a history of continuous corn production.
- All corn rootworm trait products provided a significant improvement in yield compared to the negative control under corn rootworm pressure.

## A NEW CORN ROOTWORM MANAGEMENT TOOL

- Western and northern corn rootworms have a history of adapting to and overcoming control practices, which has increased the complexity and difficulty of successfully managing these pests.
- Field-evolved resistance in western corn rootworm has now been documented for all four Bt traits for corn rootworm protection currently on the market.
- Ribonucleic acid interference (RNAi) technology has been commercialized to provide an additional unique mode of action for protection against corn rootworm and is available in Corteva Agriscience seed brands in Vorceed™ Enlist® corn.



**Figure 1.** Corn rootworm protection modes of action in Qrome corn (dual-mode Bt) and Vorceed Enlist corn (Dual-mode Bt + RNAi).

## STUDY DESCRIPTION

- Field experiments were conducted in 2020, 2021, and 2022 to evaluate the efficacy of the corn rootworm traits in Qrome corn and Vorceed Enlist corn for reducing root feeding and protecting corn yield.
- The field experiments were conducted at locations with a history of continuous corn production or locations where a trap crop was used to boost corn rootworm pressure.
- A total of four different hybrid families were used across the research locations, representing 108 and 113 comparative relative maturity (CRM) groups.
- Four different combinations of corn rootworm traits and insecticide seed treatments were compared in the study (Table 1). The experiments used the major components of Qrome corn and Vorceed Enlist corn without the integrated refuge component.

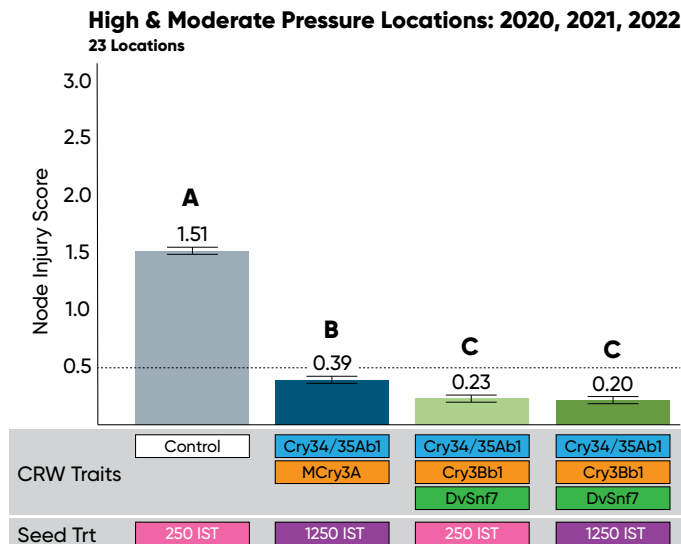
**Table 1.** Corn rootworm treatments compared in 2020, 2021, and 2022 field experiments.

Treatment Description	CRW Traits	Insecticide Seed Treatment Rate (clothianidin)
Unprotected Check	none	250 IST
CRW Traits in Qrome + 1250 rate IST	Cry34/35Ab1 mCry3A	1250 IST
CRW traits in Vorceed Enlist	Cry34/35Ab1 Cry3Bb1 DvSnf7	250 IST
CRW traits in Vorceed Enlist + 1250 rate IST	Cry34/35Ab1 Cry3Bb1 DvSnf7	1250 IST

## RESULTS

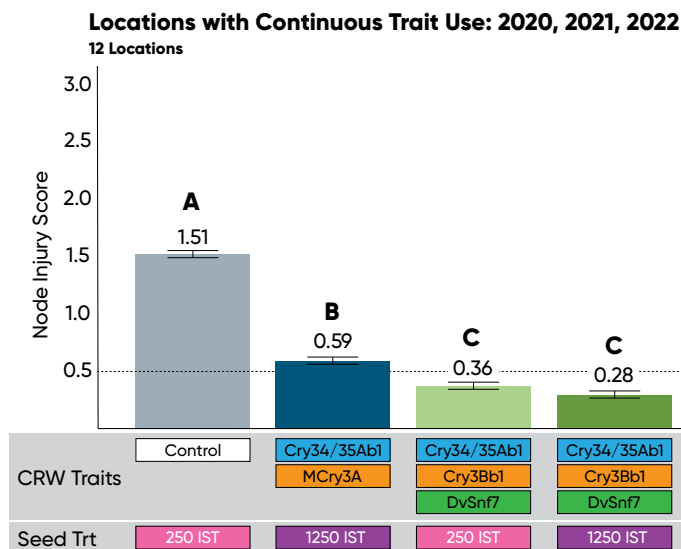
- All three corn rootworm protection treatments were effective at keeping corn rootworm feeding below a corn rootworm node injury score (CRWNIS) of 0.5 (Figure 2).
- The two treatments with the Vorceed Enlist corn rootworm traits (dual-mode Bt + RNAi) had significantly lower CRWNIS than the Qrome corn rootworm traits (dual-mode Bt).





**Figure 2.** Corn rootworm node injury scores across 23 moderate and high-pressure locations. Bars with the same letter are not significantly different at  $\alpha = 0.05$ .

- Among a subset of moderate and high corn rootworm pressure locations with a history of continuous corn rootworm trait use, all corn rootworm treatments significantly reduced feeding compared to the unprotected check, but CRWNIS scores were slightly higher (Figure 3).
- The two treatments with the Vorceed™ Enlist® corn rootworm traits had CRWNIS under 0.50, but the CRWNIS for the Qrome® corn rootworm traits slightly exceeded this threshold.

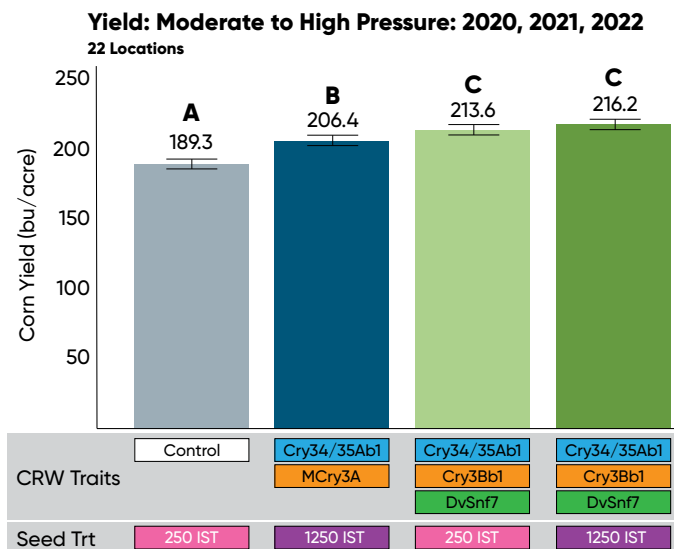


**Figure 3.** Corn rootworm node injury scores across 23 moderate and high-pressure locations. Bars with the same letter are not significantly different at  $\alpha = 0.05$ .



**Figure 4.** The corn rootworm node injury score (CRWNIS) rating system ranges from 0 to 3 based on the number of roots pruned by corn rootworm feeding to within 1.5 inches of the crown. A maximum score of 3.0 corresponds to 3 full nodes of roots pruned.

- All three corn rootworm protection treatments provided significant improvement to yield compared to the unprotected check under moderate to high corn rootworm pressure (Figure 5).
- The two treatments with the Vorceed Enlist corn rootworm traits had significantly higher yield than the Qrome corn rootworm traits.
- The addition of a 1250 rate insecticide seed treatment to the Vorceed Enlist corn rootworm traits provided slight numerical advantages in CRWNIS and yield, but none were statistically significant.



**Figure 5.** Corn yield across 23 moderate and high-pressure locations. Bars with the same letter are not significantly different at  $\alpha = 0.05$ .



# Reduced Corn Rootworm Adult Emergence With RNAi

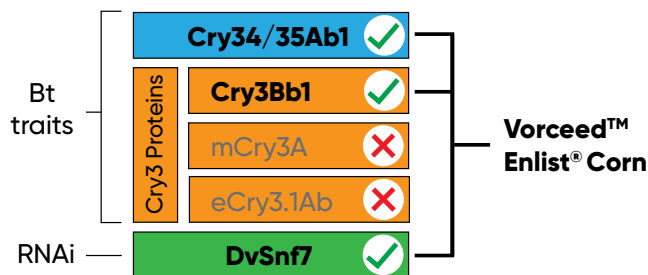
Jim Bing, Program Leader – Insect Control Traits; Tim Nowatzki, Senior Research Scientist; Tim Mabry, Field Scientist; Jeff Klever, Staff Associate Investigator; and Mark Jeschke, Ph.D., Agronomy Manager

## KEY FINDINGS

- Trials were conducted in fields with high corn rootworm pressure to evaluate the impact of corn rootworm traits on emergence of rootworm adults from the soil.
- The corn rootworm traits in Qrome® corn and Vorceed™ Enlist® corn reduced emergence of western corn rootworm beetles by 71% and 92%, respectively.
- The addition of RNAi technology in the Vorceed Enlist trait package provided a significant advantage in managing adult emergence.

## A NEW CORN ROOTWORM MANAGEMENT TOOL

- Ribonucleic acid interference (RNAi) technology has been commercialized to provide an additional unique mode of action for protection against corn rootworm and is available in Corteva Agriscience seed brands in Vorceed™ Enlist® corn.



**Figure 1.** Vorceed Enlist corn contains three modes of action for protection against corn rootworm.

## STUDY DESCRIPTION

- Field experiments were conducted in 2022 to evaluate efficacy of the corn rootworm traits in Qrome corn and Vorceed Enlist corn for reducing adult emergence.
- Experiments were conducted at six locations with natural infestations of western and northern corn rootworm.
- Study locations were specifically targeted to fields with a history of high corn rootworm pressure that were located in regions with previously reported performance issues with Bt rootworm traits.
- Adult emergence was quantified using single-plant emergence cages (Figure 2).

**Table 1.** Corn rootworm treatments compared in 2022 adult emergence experiments.

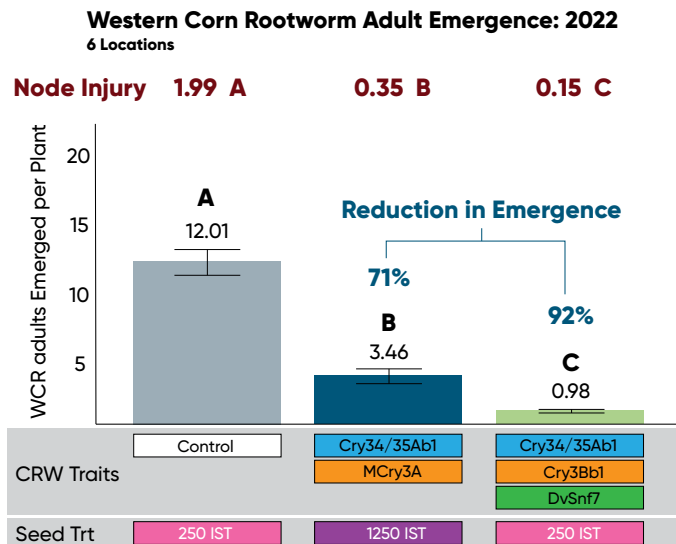
Treatment Description	CRW Traits	Insecticide Seed Treatment Rate (clothianidin)
Unprotected Check	none	250 IST
CRW Traits in Qrome + 1250 rate IST	Cry34/35Ab1	1250 IST
	MCry3A	
CRW traits in Vorceed Enlist	Cry34/35Ab1	250 IST
	Cry3Bb1	
	DvSnf7	



**Figure 2.** Emergence cage used to capture corn rootworm adults emerging from the soil.

## RESULTS

- Corn rootworm pressure was high at the study locations in 2022 – the average node injury score in the unprotected checks was 1.99 on a 0–3 scale (Figure 3).
- The corn rootworm traits in Vorceed Enlist corn and Qrome corn + 1250 rate IST both provided effective protection of corn roots against corn rootworm damage.
- The corn rootworm traits in Vorceed Enlist corn and Qrome corn + 1250 rate IST both significantly reduced emergence of western corn rootworm compared to the unprotected check (Figure 3).



**Figure 3.** Western corn rootworm adult emergence (beetles/plant). Bars and values with the same letter are not significantly different at  $\alpha = 0.05$ .

- o The addition of RNAi technology in the Vorceed™ Enlist® trait package provided a significant advantage in controlling adult emergence.
- o The corn rootworm traits in Qrome® corn + 1250 rate IST reduced adult emergence by 71%, which is lower than would generally be expected over a larger range of environments and is reflective of the high rootworm pressure conditions that were specifically targeted for this study.
- o Results of this study demonstrate the additional value provided by the RNAi technology in the Vorceed Enlist trait package for reducing adult emergence under the most extreme corn rootworm pressure conditions.

### MANAGEMENT CONSIDERATIONS

- o Corn rootworm challenges are localized and need to be managed on a field-by-field basis with a proactive, multi-year approach that employs multiple tactics to maintain low corn rootworm populations in the field.
- o Historically, the use of crop rotation and insecticidal sprays targeting corn rootworm adult beetles have been the primary tactics growers could use to lower corn rootworm populations in fields.
- o The RNAi technology in the Vorceed Enlist trait package provides another effective tool for managing the density of corn rootworm populations in fields in addition to protecting roots.
- o Use of Vorceed Enlist Corn along with in-season beetle scouting should allow for the effective use of pyramided Bt rootworm products (without the RNAi trait) or non-rootworm corn treated with soil insecticide as options in the field in the subsequent season, extending the life of the RNAi technology.

## CORN ROOTWORM BEST MANAGEMENT PRACTICES

### 1. Plant the Required Refuge

#### 2. Rotate Crops

- » Rotate at least every 3rd year in the following scenarios:
  - In long-term continuous corn system
  - CRW populations are high
  - Experiencing problems with CRW trait performance
- » In areas where rotational-resistant CRW variants exist, CRW management options may be needed the following year.

#### 3. Rotate Traits

- » Use Bt hybrids with multiple modes of action for CRW control whenever possible.
- » Use a non-Bt-traited hybrid with insecticide.

## MANAGE CRW WITH INSECTICIDES

- » Adult CRW management considerations:
  - Scout fields for CRW adults during silking stage, as CRW adults feed on corn silks and may reduce yield.
  - Foliar sprays may be an option if CRW beetle populations reach an economic threshold for damage.
  - Follow university extension or local crop consultant recommendations for products, rates, and proper timing of adult spray applications for reducing CRW beetle populations.
- » Larval CRW management considerations:
  - Soil-applied insecticides are not recommended for control of CRW in Bt-traited corn hybrids except under limited circumstances.
  - Consult with extension, crop consultants or other local experts for recommendations when considering a combination of CRW traits and soil applied insecticides.
  - Soil-applied insecticides should not be necessary for CRW control with pyramided CRW-traited Bt corn hybrids.



# Extended Diapause in Northern Corn Rootworm

Mark Jeschke, Ph.D., Agronomy Manager

## KEY POINTS:

- Northern corn rootworm has adapted to crop rotation in some areas by altering its overwintering dormancy period via a mechanism called extended diapause.
- Populations exhibiting extended diapause have eggs that remain viable in the soil for two or more years before hatching, allowing the insect population to survive until corn returns to the rotation.
- Rotation-resistant northern corn rootworm can now be found throughout much of the northern Corn Belt and continues to expand its range to the south and east.
- Even with the extended diapause adaptation, crop rotation remains a highly effective management tactic.

## CORN ROOTWORM

- Corn rootworm has long been one of the most damaging insect pests of corn in North America.
- The western corn rootworm (*Diabrotica virgifera virgifera*) and northern corn rootworm (*D. barberi*) can both be found throughout much of the Corn Belt, often coexisting in the same fields.
- Both species have a history of adapting to, and overcoming control practices, which has increased the complexity and difficulty of successfully managing these pests.



**Western Corn Rootworm**

- Has three stripes, or one broad stripe, on the wing covers.
- The legs are partially black but not banded.



**Northern Corn Rootworm**

- Solid green color. Newly emerged adults may be tan or light yellow in coloration.
- No stripes or spots on the wing covers.

## CROP ROTATION AS A MANAGEMENT STRATEGY

- Crop rotation is the most effective and widely used management strategy for corn rootworm today.
- Crop rotation works by depriving newly-hatched larvae of a food source.
  - » Corn rootworm larvae need corn roots within close proximity to feed on in order to survive.
  - » A field that has been rotated to a different crop lacks this food source, causing the larvae to starve and die.
- However, both western and northern corn rootworm have developed adaptations that have reduced the effectiveness of crop rotation in many areas.
  - » Western corn rootworm began laying eggs in soybean fields, allowing larvae to survive the subsequent season until the field was rotated back into corn.
  - » Northern corn rootworm adapted its lifecycle, altering its overwintering dormancy period via a mechanism called **extended diapause**.



**Figure 1.** Newly-hatched corn rootworm larvae cannot move very far in the soil—only around 18 inches—so corn roots must be in close proximity for them to feed and survive.

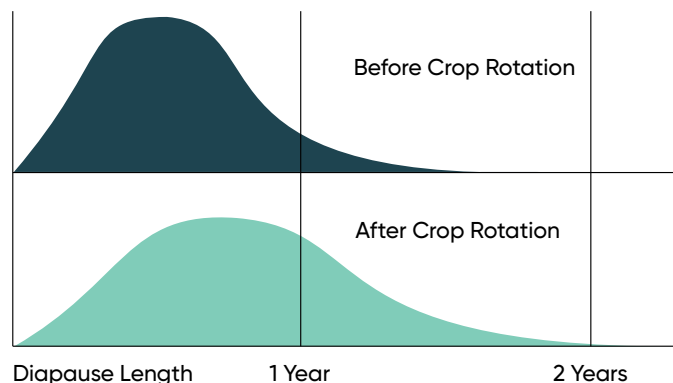
## WHAT IS DIAPAUSE?

- Diapause is a delay in development in response to regular and recurring periods of adverse environmental conditions.
- Diapause is a common adaptation of insect species in temperate regions to allow populations to survive over the winter.
- Winter dormancy for corn rootworm eggs overwintering in the soil consists of two phases: **obligate diapause** and **facultative quiescence** (Krysan, 1978).
- **Obligate diapause** begins in the fall when embryonic development ceases in eggs that have been deposited in the soil.
- The duration of diapause is genetically determined, hence the term *obligate* diapause.
- Duration of diapause can vary widely across populations and among individuals within a population (Branson, 1976; Krysan, 1982).

- The end of diapause often occurs sometime during the winter. At this point, dormancy enters the **facultative quiescence** phase, during which environmental conditions become the controlling factor in maintaining dormancy.
- Embryonic development remains suspended until soil temperature increases above a threshold at which development can resume.
- This two-phase dormancy allows insects to survive harsh winter conditions while being ready to resume development as soon as conditions turn favorable.

## EXTENDED DIAPAUSE IN NORTHERN CORN ROOTWORM

- Northern corn rootworm populations exhibiting extended diapause have eggs that remain viable in the soil for two or more years before hatching, allowing the insect population to survive until corn returns to the rotation.
- Selection pressure imposed on corn rootworm populations selects for individuals with a diapause duration that gives them the best chance for survival by timing hatch to correspond with food availability.
- Diapause length in northern corn rootworm is naturally variable, and populations have been able to use this variability to adapt to different crop rotation schemes.
- Repeated use of crop rotation as a means of control selected for individuals with a longer diapause period that allowed eggs to hatch when the field was rotated back to corn.



**Figure 2.** Distribution of diapause length in northern corn rootworm populations under continuous corn and after an extended period of corn-soybean rotation.

- Extended diapause can last up to four years and has shown adaptability to rotation patterns over time; e.g., fields with corn every other year have a relatively high percentage of eggs that hatch in the second year, and fields with corn every third year tend to have more eggs that hatch the third year, etc. (Levine et al., 1992).

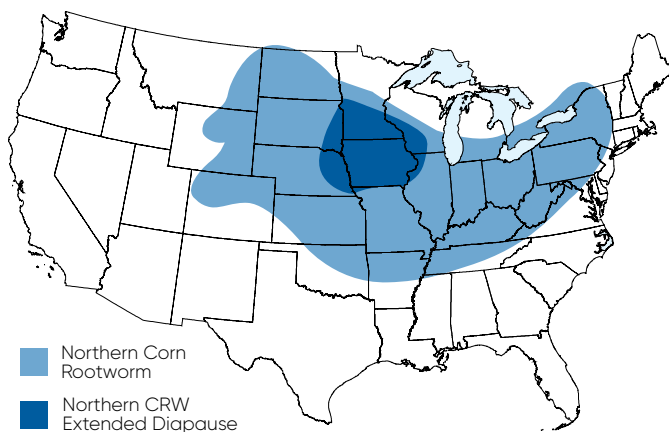


## EFFECT OF ENVIRONMENTAL CONDITIONS

- Diapause in northern corn rootworm is genetically controlled, but the duration of dormancy is also influenced by environmental conditions.
- Exposure to low temperatures has been shown to accelerate dormancy termination in some insect species, including northern corn rootworm.
- Research has shown that northern corn rootworm eggs may need to be exposed to a minimum number of low temperature units before dormancy ends (Fisher et al., 1994).
- The range for these low temperature units appears to be between 37° F and 59° F (3° C and 15° C). Temperatures above or below this range do not affect the duration of dormancy.
- Consequently, an overwintering period with a below average number of days falling within this temperature range may extend dormancy and result in a greater proportion of the rootworm population hatching the following year.

## OCCURRENCE AND SPREAD OF EXTENDED DIAPAUSE

- Instances of northern corn rootworm damage to corn grown in rotation with other crops was noted as far back as the 1930s.
- Rotation-resistant northern corn rootworm can now be found throughout much of the northern Corn Belt and continues to expand its range to the south and east.



**Figure 3.** Approximate distribution of northern corn rootworm and extended diapause populations.

## MANAGEMENT CONSIDERATIONS

- Corn growers within or near the geographic area where extended diapause has been observed should be on the lookout for rootworm damage in first-year corn fields.
- Employ best management practices for corn rootworm that focus on controlling population levels using an integrated management strategy.
- Crop rotation can still have value in extended diapause areas for reducing rootworm population levels, particularly if western corn rootworm is present as well.

# Tar Spot of Corn in the U.S. and Canada

Mark Jeschke, Ph.D., Agronomy Manager

- Tar spot (*Phyllachora maydis*) is a relatively new disease of corn in the U.S., first appearing in Illinois and Indiana in 2015 and subsequently spreading to neighboring states.
- In 2018, tar spot established itself as an economic concern for corn production in the Midwest, with severe outbreaks affecting corn yield reported in several states.
- Tar spot gets its name from the fungal fruiting bodies it produces on corn leaves that look like spots of tar, developing black oval or circular lesions on the corn leaf.
- Tar spot is favored by cool temperatures (60–70° F, 16–20° C), high relative humidity (>75%), frequent cloudy days, and 7+ hours of dew at night.
- Tar spot can rapidly spread through the corn canopy under favorable conditions, causing premature leaf senescence.
- Commercial corn hybrids vary widely in their tar spot susceptibility. Hybrid selection should be a primary consideration in managing for tar spot.
- Fungicide treatments have proven effective in reducing tar spot symptoms; however, application timing can be critical for achieving adequate control and two applications may be needed in some cases.

"*Phyllachora maydis* is part of a large genus of fungal species that cause disease in numerous other species."

## TAR SPOT: AN EMERGING DISEASE OF CORN

Tar spot is a foliar disease of corn that has recently emerged as an economic concern for corn production in the Midwestern U.S. It is not a new disease, having been first identified in 1904 in high valleys in Mexico. Historically, tar spot's range was limited to high elevations in cool, humid areas in Latin America, but it has now spread to South American tropics and parts of the U.S. and Canada. It first appeared in the U.S. in 2015. During the first few years of its presence in the U.S., tar spot appeared to be a minor cosmetic disease that was not likely to affect corn yield. However, widespread outbreaks of severe tar spot in multiple states in 2018 and again in 2021 proved that it has the potential to cause a significant economic impact. With its very limited history in the U.S. and Canada, much remains to be learned about the long-term economic importance of this disease and best management practices.

### TAR SPOT ORIGINS

Tar spot in corn is caused by the fungus *Phyllachora maydis*, which was first observed over a century ago in high valleys in Mexico. *P. maydis* was subsequently detected in several countries in the Caribbean and Central and South America (Table 1). Despite its decades-long presence in many of these countries, it was not detected in the U.S. until 2015.

Historically, *P. maydis* was not typically associated with yield loss unless a second pathogen, *Monographella maydis*, was also present, the combination of which is referred to as tar spot complex. In Mexico, the complex of *P. maydis* and *M. maydis* has been associated with yield losses of up to 30% (Hock et al., 1995). In some cases, a third pathogen, *Coniothyrium phyllachorae*, has been associated with the complex. Only *P. maydis* is known to be present in the United States but it has proven capable of causing significant yield losses, even without the presence of an additional pathogen.

**Table 1.** Country and year of first detection of *P. maydis* in corn (Valle-Torres et al., 2020).

Region	Country	Year
Caribbean	Dominican Republic	1944
	U.S. Virgin Islands	1951
	Trinidad and Tobago	1951
	Cuba	1968
	Puerto Rico	1973
	Haiti	1994
Central America	Guatemala	1944
	Honduras	1967
	Nicaragua	1967
	Panama	1967
	El Salvador	1994
	Costa Rica	1994
North America	Mexico	1904
	United States	2015
	Canada	2020
South America	Peru	1931
	Bolivia	1949
	Colombia	1969
	Venezuela	1972
	Ecuador	1994



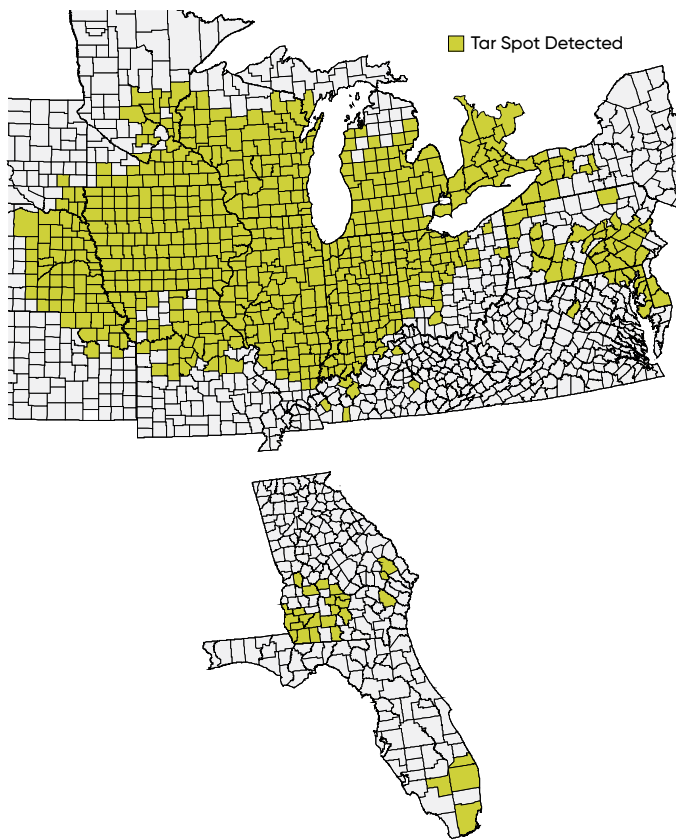
Corn leaves infected with tar spot in an Illinois field in 2018.

### TAR SPOT SPREAD TO THE U.S. AND CANADA

The first confirmations of tar spot in North America outside of Mexico were in Illinois and Indiana in 2015 (Bissonnette, 2015; Ruhl et al., 2016). It has subsequently spread to Michigan (2016), Wisconsin (2016), Iowa (2016), Ohio (2018), Minnesota (2019), Missouri (2019), Pennsylvania (2020), Ontario (2020), Kentucky (2021), New York (2021), Nebraska (2021), Kansas (2022), South Dakota (2022), Maryland (2022), Delaware (2023), and Virginia (2023). Its presence was also confirmed in Florida in 2016 (Miller, 2016) and in Georgia in 2021.

#### 2018 Outbreak

During the first few years of its presence in the U.S., it appeared that tar spot might remain a relatively minor cosmetic disease of little economic impact. In 2018, however, tar spot established itself as an economic concern for corn production in the Midwest, with severe outbreaks reported in Illinois, Indiana, Wisconsin, Iowa, Ohio, and Michigan. Significant corn yield losses associated with tar spot were reported in some areas. University corn hybrid trials conducted in 2018 suggested potential yield losses of up to 39 bu/acre under the most severe infestations (Telenko et al., 2019). Growers in areas severely impacted by tar spot anecdotally reported yield reductions of 30–50% compared to 2016 and 2017 yield levels. However, yield losses specifically attributable to tar spot were often difficult to determine as conditions favorable for disease development resulted in the presence of other corn diseases in addition to tar spot. Instances of greatest tar spot severity in 2018 were largely concentrated in northern Illinois and southern Wisconsin, where other foliar diseases and stalk rots were also prevalent.



**Figure 1.** Counties with confirmed incidence of tar spot, as of October 2023. (Corn ipmPIPE, 2023).

### 2019 and 2020 Observations

In 2019, tar spot severity was generally lower across much of the Corn Belt and appeared later and more slowly compared to 2018, although severe infestations were still observed in some areas. There is no clear explanation for why tar spot severity was lower in 2019 in areas where it was severe 2018. Less favorable conditions for disease development during the latter part of the growing season in 2019 may have played a role. Reduced winter survival may have been a factor as well. Winter temperatures in some tar spot-affected areas oscillated between warm periods and extreme cold, which may have affected fungal dormancy and survival (Kleczewski, 2019).

Despite the generally lower disease severity, tar spot continued to expand its geographic range in 2019. In Iowa, tar spot presence was limited to around a dozen eastern counties in 2018 but expanded to cover most of the state in 2019 (Figure 1). Tar spot was confirmed in Minnesota for the first time in September of 2019 (Malvick, 2019). Tar spot spread to the south and east as well, with new confirmations in parts of Missouri, Indiana, Ohio, and Michigan.

Another year of generally lower tar spot severity hit the Corn Belt in 2020, with severe infestations mostly limited to irrigated corn, and areas that received greater than average rainfall or developing late enough in the season that they had minimal

impact on yield. Tar spot continued to spread, however, with the first confirmation of tar spot in Pennsylvania. Tar spot was also confirmed to be present in corn in Ontario, marking the first time the disease had been detected in Canada.

### 2021 Outbreak

The 2021 growing season proved that the 2018 outbreak was not a fluke, with a severe outbreak of tar spot once again impacting corn over a large portion of the Corn Belt. Wet conditions early in the summer appeared to be a key factor in allowing tar spot to get a foothold in the crop. Whereas in 2018, when tar spot appeared to be mainly driven by wet conditions in August and September, in 2021, many impacted areas were relatively dry during the latter portion of the summer. Wet conditions early in the summer were apparently enough to allow the disease to get established in the crop and enabled it to take off quickly when a window of favorable conditions opened up later in the summer. The 2021 season also provided numerous demonstrations of the speed with which tar spot can proliferate, enabled by its rapid reinfection cycle (Figure 2).



**Figure 2.** A corn field with almost no visible foliar disease on August 28, 2021, and the same field with extensive tar spot infection on September 23, 2021.



## 2022: The Tar Spot Story Gets More Complex

The 2022 season also had generally low to moderate tar spot severity in most affected areas, similar to the 2019 and 2020 growing seasons. Dry summer conditions experienced in many areas of the Corn Belt may have helped keep tar spot in check. Greater familiarity with the disease following several years of infestation and two major outbreaks may also be driving more a more proactive approach to management with foliar fungicides when symptoms begin to develop.

Tar spot made another substantial expansion westward in 2022, with its presence confirmed for the first time in numerous eastern Nebraska counties as well as a few counties in northeastern Kansas. Eastward spread was more limited, with only a handful of new confirmations in counties in Pennsylvania, New York, and Maryland. Infestation continued to spread in the southern U.S., with several new confirmations in Georgia.

*"Tar spot was detected in two new states in 2023 – Virginia and Delaware – and continued its westward expansion."*

A study published in 2022 (Broders et al., 2022) shed new light on the pathogen that causes tar spot, *Phyllachora maydis*. Previously, it was thought that *P. maydis* was not in the U.S. prior to 2015 and that it was not capable of infecting any species other than corn. Results from the new study indicate that both of these hypotheses were wrong. Even more notably, the study revealed that *P. maydis* infecting corn in the U.S. is not one species but is actually multiple, related but genetically distinct, species. In light of these new findings, the authors proposed the term *P. maydis* species complex to refer to the causal pathogen for tar spot in corn pending further research.

The study assessed sequence diversity of numerous tar spot specimens from field samples as well as herbarium samples of corn and several other grass species. Results revealed five genetically distinct *Phyllachora* species, three of which are currently found in corn in the U.S.:

### Species 1 (In U.S. Corn)

- Found only in corn
- Found only in field samples from Indiana and Ohio

### Species 2 (In U.S. Corn)

- Found only in corn
- Found in herbarium samples from Colombia and Puerto Rico and field samples from Puerto Rico, Mexico, Florida, Illinois, and Michigan

### Species 3 (In U.S. Corn)

- Widest geographic and host range
- Found in several U.S. states and a dozen other countries around the world
- Found in corn as well as 10 other host species, including monocots and dicots
- Includes first isolate collected from U.S. corn in 2015 and the original specimen collected in Mexico in 1904

- Herbarium samples indicate that Species 3 has been present in the Southwestern U.S. since at least the 1940s in native grass species, but not in corn

### Species 4

- Found in herbarium samples of corn from Guatemala and Venezuela
- Found in field samples of other grass species in the U.S. but NOT in corn.

### Species 5

- Not found in corn.
- Found in some of the same grass species as Species 4.

## 2023 Observations

Drought and heat stress were major factors during the 2023 growing season across much of the Corn Belt, which tended to keep foliar diseases – including tar spot – in check in many areas. Tar spot pressure often stayed low or ramped up late enough in the season that it had little to no yield impact. A notable exception was parts of eastern Nebraska and northern Missouri along the Missouri River that experienced high levels of tar spot and areas with yield loss and standability challenges. Tar spot was detected in two new states in 2023 – Virginia and Delaware – and continued its westward expansion, with first detections in numerous counties in Nebraska, Kansas, and Missouri.

## IDENTIFICATION AND SYMPTOMS

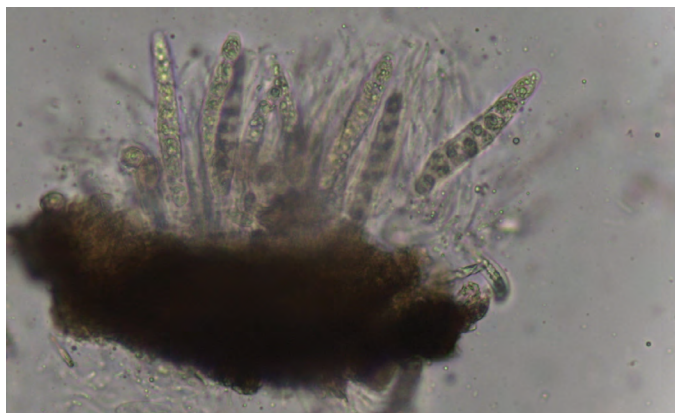
Tar spot is the physical manifestation of fungal fruiting bodies, the ascomata, developing on the leaf. The ascomata look like spots of tar, developing black oval or circular lesions on the corn leaf (Figure 3). The texture of the leaf becomes bumpy and uneven when the fruiting bodies are present. These black structures can densely cover the leaf and may resemble the pustules of rust fungi (Figure 3 and 4). Tar spot spreads from the lowest leaves to the upper leaves, leaf sheathes, and eventually the husks of the developing ears (Bajet et al., 1994).



**Figure 3.** A corn leaf with tar spot symptoms.



**Figure 4.** Corn leaf under magnification, showing dense coverage with tar spot ascomata

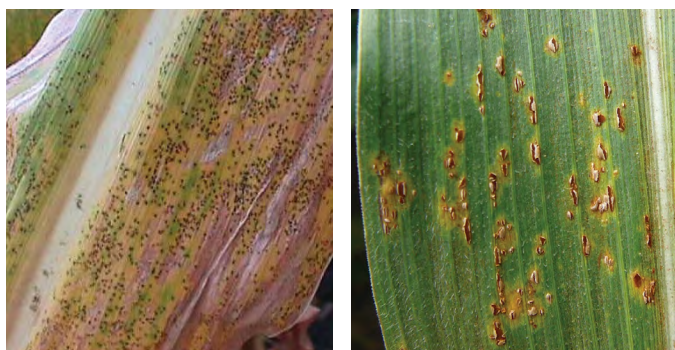


**Figure 5.** Microscopic view of fungal spores of *P. maydis*.

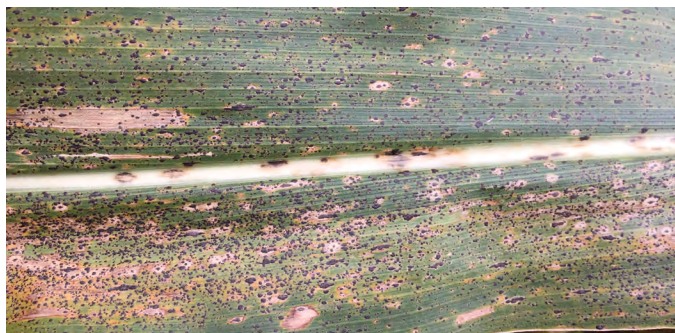
Under a microscope, *P. maydis* spores can be distinguished by the presence of eight ascospores inside an elongated ascus, resembling a pod containing eight seeds (Figure 5).

### Tar Spot Look-Alikes

Common rust (*Puccinia sorghi*) and southern rust (*Puccinia polysora*) can both be mistaken for tar spot, particularly late in the growing season when pustules on the leaves produce black teliospores (Figure 6a). Rust pustules can be distinguished from tar spot ascomata by their jagged edges caused by the spores breaking through the epidermis of the leaf (Figure 6b). Rust spores can be scraped off the leaf surface with a fingernail, while tar spot cannot. Saprophytic fungi growing on senesced leaf tissue can also be mistaken for tar spot.



**Figure 6a.** Southern rust in the teliospore stage late in the season, which can resemble tar spot (left). **Figure 6b.** Corn leaf with common rust spores showing jagged edges around the pustules (right).



**Figure 7.** Corn leaf with tar spot symptoms.

## TAR SPOT ARRIVAL AND SPREAD IN THE U.S.

The mechanism by which tar spot arrived in the Midwestern and Southeastern U.S. and the reason for its recent establishment and proliferation in the U.S. and Canada, despite being present in Mexico and several Central American countries for many decades prior, both remain unclear.

Following its initial detection in the U.S. in 2015, numerous reports speculated that *P. maydis* spores may have been carried to the U.S. via air currents associated with a hurricane, the same mechanism believed to have brought Asian soybean rust (*Phakopsora pachyrhizi*) to the U.S. several years earlier. However, Mottaleb et al. (2018) suggested that this scenario was unlikely and that it is more plausible that spores were brought into the U.S. by movement of people and/or plant material. Ascospores of *P. maydis* are not especially aerodynamic and are not evolved to facilitate spread over extremely long distances by air. Tar spot was observed in corn in Mexico for over a century prior to its arrival in the U.S., during which time numerous hurricanes occurred that could have carried spores into the U.S. Chalkley (2010) notes that *P. Maydis* occurs in cooler areas at higher elevations in Mexico, which, coupled with its lack of alternate hosts, would limit its ability to spread across climatic zones dissimilar to its native range. Chalkley also notes the possibility of transporting spores via fresh or dry plant material and that the disease is not known to be seedborne.

As for the reason for tar spot's establishment and spread as a disease capable of severely reducing corn yield, Broders et al. note two possible contributing factors. The first is that changes in climate have favored the disease. Shorter and warmer winters may be allowing *P. maydis* to overwinter further north than previously possible and greater temperature and precipitation could contribute to epidemics during the growing season. Secondly, the overall lack of resistance to *P. maydis* in North American corn genetics has made corn in the U.S. and Canada a particularly vulnerable host population. Corn hybrids have been shown to vary in their susceptibility to tar spot. Corn breeding programs in Central and South American – countries where tar spot has long been present – would have selected for more resistant genetics, whereas breeding programs in the U.S. and Canada, until very recently, would not.

## TAR SPOT EPIDEMIOLOGY

Much is still being learned about the epidemiology of tar spot, even in its native regions, and especially in the U.S. and Canada. *P. maydis* is part of a large genus of fungal species that cause disease in numerous other species. *P. maydis* is the only *Phyllachora* species known to infect corn, and, until very recently, was believed to only infect corn (Chalkley, 2010). The recent confirmation of the existence of multiple, related *P. maydis* species infecting corn, some of which can infect other hosts as well, has added another layer of complexity to the situation.

*P. maydis* is an obligate pathogen, which means it needs a living host to grow and reproduce. It is capable of overwintering in the Midwestern U.S. in infected crop residue on the soil surface. Tar spot is favored by cool temperatures (60–70°F, 16–20°C), high relative humidity (>75%), frequent cloudy days, and 7+ hours of dew at night. Tar spot is polycyclic and can continue to produce spores and spread to new plants as long as environmental conditions are favorable. *P. maydis* produces windborne spores that have been shown to disperse up to 800 ft. Spores are released during periods of high humidity.

○ *"Genetic resistance to tar spot should be the number one consideration when seeking to manage this disease."*

## MANAGEMENT CONSIDERATIONS

### Yield Impact

The first time that corn yield reductions associated with tar spot were documented in the U.S. was 2018. University corn hybrid trials conducted in 2018 suggested potential yield losses of up to 39 bu/acre under heavy infestations (Telenko et al., 2019). Pioneer on-farm research trials, along with grower reports, showed yield losses of up to 50% under the most extreme infestations during the 2018 season and again in the 2021 growing season.

### Differences in Hybrid Response

Observations in hybrid trials have shown that hybrids differ in susceptibility to tar spot (Kleczewski and Smith, 2018; Ross et al., 2023). Tar spot affects yield by reducing the photosynthetic capacity of leaves and causing rapid premature leaf senescence. Longer maturity hybrids for a given location have been shown to have a greater risk of yield loss from tar spot than shorter maturity hybrids (Telenko et al., 2019). Pioneer agronomists and sales professionals continue to



**Figure 8.** Pioneer on-farm trial in Knox County, Illinois, with high tar spot pressure showing differences in canopy staygreen among hybrids (September 2022).

collect data on disease symptoms and hybrid performance in locations where tar spot is present to assist growers with hybrid management. Pioneer hybrid trials have shown differences in canopy staygreen among Pioneer® brand corn products\* and competitor products under tar spot disease pressure (Figure 8). Genetic resistance to tar spot should be the number one consideration when seeking to manage this disease.

### Stalk Quality

Severe tar spot infestations have been associated with reduced stalk quality (Figure 9). Stress factors that reduce the amount of photosynthetically functioning leaf area during grain fill can increase the plant's reliance on resources remobilized from the stalk and roots to complete kernel fill. Remobilizing carbohydrates from the stalk reduces its ability to defend against soil-borne pathogens, which can lead to stalk rots and lodging.

Tar spot seems to be particularly adept at causing stalk quality issues due to the speed with which it can infest the corn canopy, causing the crop to senesce prematurely. If foliar symptoms are present, stalk quality should be monitored carefully to determine harvest timing.



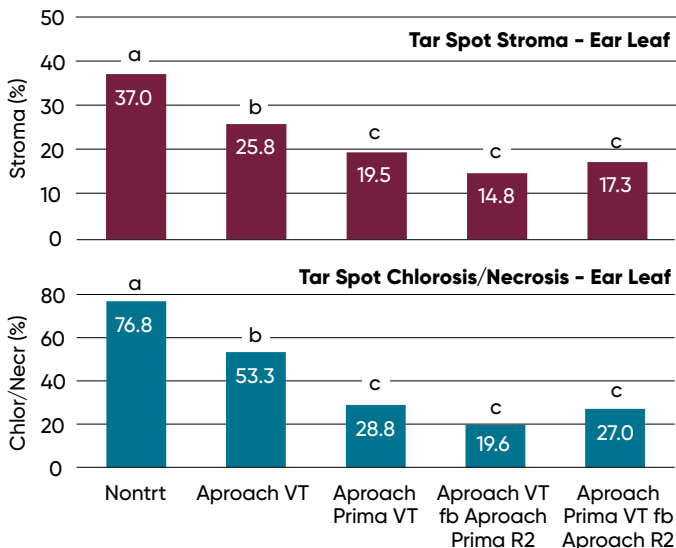
**Figure 9.** A 2018 field with severe tar spot infection and extensive stalk lodging in Wisconsin.

### Fungicide Treatments

Research has shown that fungicide treatments can be effective against tar spot (Bajet et al., 1994; Da Silva et al., 2019; Ross et al., 2023). A multistate university study conducted in 2020 and 2021 showed that fungicide treatments with multiple modes of action were better at reducing tar spot severity and protecting corn yield than those with only a single mode of action (Telenko et al., 2022).

“Severe infestations of tar spot may be challenging to control with a single fungicide application due to its rapid reinfection cycle.”

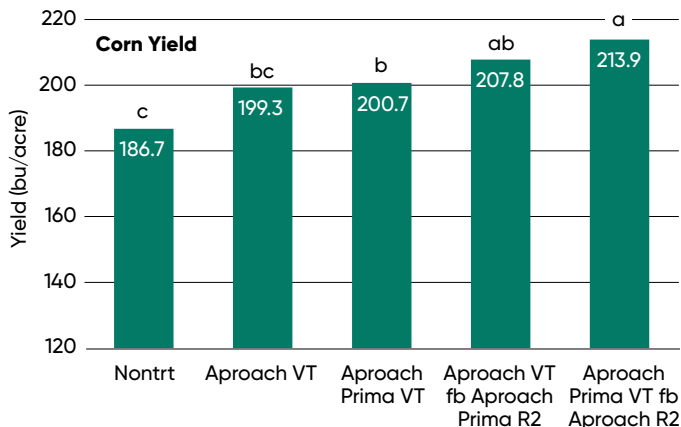
Severe infestations of tar spot may be challenging to control with a single fungicide application due to its rapid reinfection cycle, particularly in irrigated corn. A 2019 Purdue University study compared single-pass and two-pass treatments for tar spot control using Aproach® (picoxystrobin) and Aproach® Prima (picoxystrobin + cyproconazole) fungicides under moderate to high tar spot severity (Da Silva et al., 2019).



**Figure 10.** Fungicide treatment effects on tar spot symptoms in a 2019 Purdue University study. Visually assessed tar spot stroma and chlorosis/necrosis (0-100%) on the ear leaf.

Means followed by the same letter are not significantly different based on Fisher's Least Significant Difference test (LSD;  $\alpha=0.05$ )

Fungicide treatments were applied at the VT (August 8) and R2 stage (August 22), and disease symptoms were assessed on September 30. Results showed that all treatments significantly reduced tar spot symptoms relative to the nontreated check, with Aproach Prima fungicide applied at VT and two-pass treatments at VT and R2 providing the greatest reduction in tar spot stroma and associated chlorosis and necrosis on the ear leaf (Figure 10).



**Figure 11.** Fungicide treatment effects on corn yield in a 2019 Purdue University study.

Means followed by the same letter are not significantly different based on Fisher's Least Significant Difference test (LSD;  $\alpha=0.05$ )

Aproach® Prima fungicide applied at VT and the two-pass treatments all significantly increased yield relative to the nontreated check. Aproach Prima fungicide applied at VT followed by Aproach® fungicide at R2 had the greatest yield, although it was not significantly greater than Aproach followed by Aproach Prima (Figure 11).

On-farm fungicide trials conducted in 2021 appeared to confirm concerns that the rapid reinfection rate of tar spot would make it difficult to control with a single pass fungicide treatment. Precise application timing was often critical, and two applications were necessary in some cases to provide adequate tar spot control. Disease forecasting models, such as Tarspotter, developed at the University of Wisconsin, may be helpful in optimizing timing of fungicide applications. Tarspotter uses several variables, including weather, to forecast the risk of tar spot fungus being present in a corn field.

<https://ipcm.wisc.edu/apps/tarspotter/>

Several foliar fungicide products are available for management of tar spot in corn. (Table 2). Aproach® and Aproach® Prima fungicides have both received FIFRA 2(ee) recommendations for control/suppression of tar spot of corn.

### Agronomic Practices

The pathogen that causes tar spot overwinters in corn residue but to what extent the amount of residue on the soil surface in a field affects disease severity the following year is unknown. Spores are known to disperse up to 800 ft, so any benefit from rotation or tillage practices that reduce corn residue in a field may be negated by spores moving in from neighboring fields. Evidence so far suggests that rotation and tillage probably have little effect on tar spot severity. A 3-year Purdue University study that compared strip-till and conventional tillage found no effect on tar spot severity in the subsequent growing season (Ross et al., 2023).

Agronomists have noted that infestation may occur earlier in corn following corn fields, where infection proceeds in a “bottom-up” manner from inoculum present in the soil, in contrast to rotated fields that more commonly exhibit “top-down” pattern of infection from spores blowing in from other fields.

Duration of leaf surface wetness appears to be a key factor in the development and spread of tar spot. Farmers with irrigated corn in areas affected by tar spot have experimented with irrigating at night to reduce the duration of leaf wetness, although the potential effectiveness of this practice to reduce tar spot has not yet been determined.

Yield potential of a field appears to be positively correlated with tar spot risk, with high productivity, high nitrogen fertility fields seeming to experience the greatest disease severity in affected areas. Research on *P. maydis* in Latin America has also suggested a correlation between high nitrogen application rates and tar spot severity (Kleczewski et al., 2019).

**Mycotoxins**

There is no evidence at this point that tar spot causes ear rot or produces harmful mycotoxins (Kleczewski, 2018).

**Table 2.** Efficacy of fungicides labeled for tar spot in corn (Wise, 2023).

Product Name	Tar Spot Efficacy	Harvest Restriction
Aproach® 2.08 SC	G*	7 days
Aproach® Prima 2.34 SC	G-VG*	30 days
Affiance® 1.5 SC	G*	7 days
Delaro® Complete 3.83 SC	VG	14 days
Delaro® 325 SC	G-VG	14 days
Domark® 230 ME	G-VG*	R3
Fortix® 3.22 SC	G-VG*	R4
Preemptor™ 3.22 SC	G-VG*	30 days
Headline® AMP 1.68 SC	G-VG	20 days
Lucento®	G*	30 days
Miravis® Neo 2.5 SE	G-VG	30 days
Revytek™	VG	21 days
TopGuard® EQ	G-VG*	45 days
Trivapro® 2.21 SE	G-VG	30 days
Veltyma™	VG	21 days

G = good, VG = very good

\* A 2ee label is available for several fungicides for control of tar spot, however efficacy data are limited. Check 2ee labels carefully, as not all products have 2ee labels in all states. Always read and follow product label guidelines.

**HOW FAR WILL TAR SPOT SPREAD?**

Mottaleb et al. (2018) used climate modeling based on long-term temperature and rainfall data to predict areas at risk of tar spot infection based on the similarity of climate to the current area of infestation. Model forecasts indicated the areas beyond the then-current range of infestation at highest risk for spread of tar spot were central Iowa and northwest Ohio. Observations in subsequent growing seasons have been consistent with model predictions, with further spread of tar spot to the east in Ohio, Ontario, and Pennsylvania, and a dramatic expansion of tar spot across Iowa and into parts of Minnesota and Missouri.

As of 2023, spread of tar spot in the Corn Belt has proceeded largely as predicted back in 2018, with some expansion to the north and south but primarily to the east and west. The two primary remaining areas to which tar spot expansion was predicted but has not yet occurred are eastward across New York and westward across South Dakota, so corn growers in these areas should be on the lookout for tar spot in the coming years.



**TAR SPOT – TAR STOP**

Join us as our agronomists share experiences and images from the field and discuss management of the disease, while demonstrating the Pioneer® genetic advantage and how Pioneer corn breeders are innovating a path toward the future for managing this disease.

**[Watch at pioneer.com/webinars](https://pioneer.com/webinars)**



# Fusarium Crown Rot in Corn

Mark Jeschke, Ph.D., Agronomy Manager

## KEY POINTS:

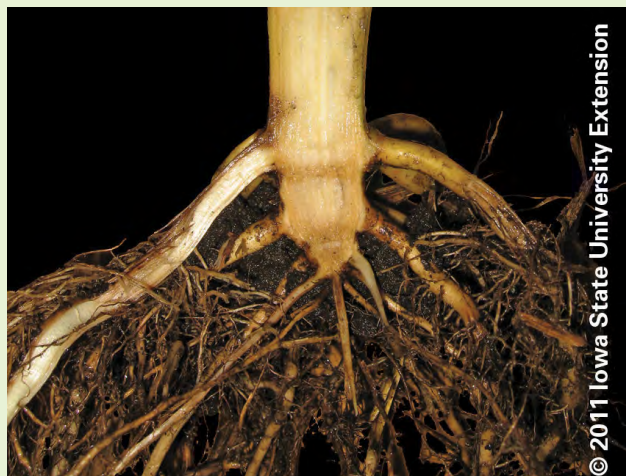
- Crown rot is a fungal infection of corn that occurs at the base of the stalk near the soil line.
- Crown rot of corn is commonly attributed to pathogens in the *Fusarium* genus, although the exact species or complex of species that cause it has yet to be determined.
- Much remains unknown about crown rot and research is ongoing to determine the casual organism(s), timing of infection in corn, environmental conditions favorable to infection, and effective management practices.

## CROWN ROT IN CORN

- Crown rot is a form of fungal infection in corn that affects corn plants at the base of the stalk near the soil line where the fungus infects the root and stalk tissue.
- Crown rot has been observed in corn plants for years but it seems to have increased in severity and frequency in recent growing seasons.
- Infection of the plant occurs early in the season but symptoms often do not become apparent until mid-season or, more commonly, when corn is nearing maturity.

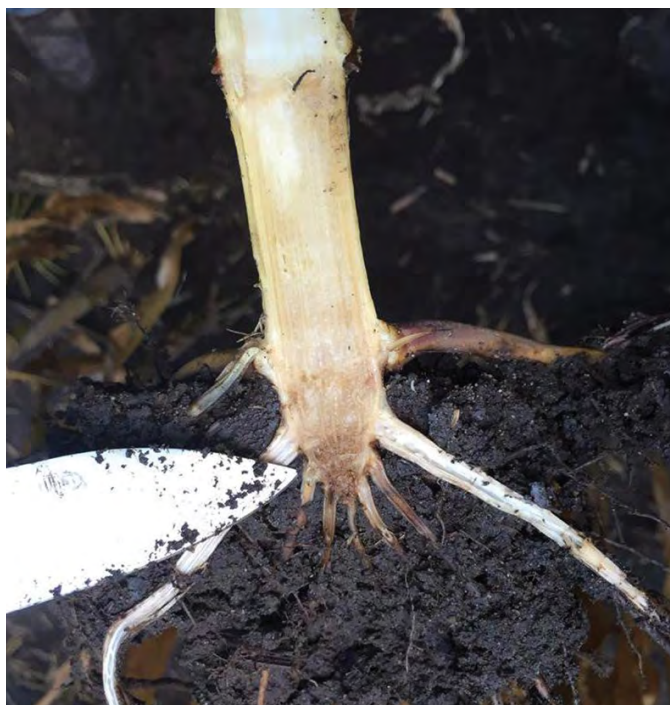
### WHAT IS THE CROWN ON A CORN PLANT?

- The term crown refers to the base of the corn stalk where the nodal roots connect to the stalk.
- The crown is the nexus between the root system and the aboveground portion of the plant, which means that the health of the crown is critical to the health of the plant.



## CAUSAL PATHOGEN

- There is much that remains unknown about factors leading to crown rot in corn, including the exact pathogen or complex of pathogens that cause it.
- Root and crown rots developing in corn after the seedling stage are most commonly associated with *Fusarium* species, although other pathogens such as *Rhizoctonia solani* and *Pythium* spp. have been associated with crown rot in some cases.
- *Fusarium* is a large and diverse genus that includes numerous species that are ubiquitous in agricultural soils and several species known to be pathogens of corn.
- Research in South Dakota showed eight different *Fusarium* species capable of causing root rot in corn (Okello et al., 2019).



**Figure 1.** Split corn stalk showing infection in the crown and root tissue.

## SYMPTOMS

- Symptoms of crown rot in corn include stunted growth, wilting, and discoloration of the lower leaves resulting from the infection of vascular tissue in the crown.
- Visual symptoms often become apparent as the field nears maturity when individual plants will begin to change color and senesce early. Affected plants will often be surrounded by healthy plants.
- Digging up affected plants and splitting the stalks will reveal dark discoloration of the crown tissue.

- As the disease progresses, the lower stalk may become discolored and rotted, and the plant may die prematurely.
- Infection can extend out into the roots or upwards in the stalk.

## SIMILAR DISEASES

- Red root rot (*Phoma terrestris*) can cause symptoms similar to those of crown rot and may appear in the same fields. Deep red to purple discoloration of crown and root tissues are associated with red root rot but may also occur with crown rot.
- *Physoderma maydis* can cause stalk rot near the base of the plant that may appear similar to crown rot. However, plants infected with *Physoderma* stalk rot will often appear otherwise healthy, with the main threat to yield coming from stalk lodging.



**Figure 2.** Crown rot of corn in a mature corn plant.

## FAVORABLE CONDITIONS

- It is difficult to identify specific environmental conditions that favor crown rot infection and development since it is not yet known precisely when infection leading to crown rot takes place.
- Cold and wet conditions early in the season are generally favorable for infection by soil-borne pathogens – wet soils favor fungal organisms and cold temperatures stress the plant, reducing its ability to fight off infection.
- The 2022 growing season was characterized by an extended cold period during April and early May in much of the Midwest. Incidences of crown rot appeared to be more common in fields that were planted early and experienced early-season cold stress.
- Crown rot can be more common in areas with heavy soil and poor drainage, although it has been observed in a variety of soil conditions.

- Field observations suggest that cold and wet conditions early, followed by hot and dry conditions later in the season, may be particularly favorable for crown rot development
- Heavy manure applications have been associated with higher incidence of crown rot in corn.
- Infection can be exacerbated by injury to the roots or crown, such as that caused by insect feeding.

## YIELD IMPACT AND MANAGEMENT

- Crown rot can reduce yield and increase the risk of lodging in affected plants.
- Plants that die prematurely due to crown rot can have lower yield due to reductions in kernel number and weight.
- Research on management practices for control of crown rot has been limited thus far due to the lack of an inoculation assay for inducing crown rot infection.
- Management recommendations are largely anecdotal at this point, based on opportunistic observations in fields where natural crown rot infection was present.

### Fungicides

- **Fungicide Seed Treatments:** Fungicide seed treatments protect against *Fusarium* species for up to six weeks after planting, but activity does not persist long enough to protect against infection occurring beyond the seedling stage.
- **In-Furrow Fungicides:** Research on the use of in-furrow fungicides for control of crown rot is ongoing but so far has not shown a consistent benefit.
- **V5-V6 Foliar Fungicides:** Early foliar fungicide applications are also being evaluated for crown rot control but have not shown a consistent benefit.
- It seems unlikely that a foliar fungicide application could be effective against crown rot. Foliar fungicides are translocated in the xylem tissue, which means they can only move upward in the plant and are unable to translocate to the base of the plant where crown rot infection occurs.

### Other Management Considerations

- Susceptibility to crown rot infection appears to vary among corn hybrids, but no hybrid ratings are currently available.
- Management practices that reduce insect feeding to the roots will help reduce susceptibility to infection as well as support the overall health of the plant and its ability to fight off infection.
- Research is underway to explore possible impacts of corn nematode injury on crown rot occurrence.
- In general, management practices that reduce stress to the corn plant will help improve its resilience against infection by fungal pathogens.

# Gibberella Ear Rot

Mark Jeschke, Ph.D., Pioneer Agronomy Manager

## DISEASE FACTS

- Caused by the fungus *Gibberella zeae*.
- Overwinters in infected crop residue.
- Spores are spread from residue to corn ears by wind and rain.
- Infection of corn ears occurs through young silks.
- Infection favored by cool, wet weather during and after pollination (optimum temperature 65° F to 70° F).
- Often a problem in the northern and eastern Corn Belt (both U.S. and Canada).
- Most common in continuous corn or corn following wheat that was infected with Fusarium head blight.



**Figure 1.** Gibberella ear rot on tip of corn ear.

## DISEASE SYMPTOMS

- Most readily identified by the red or pink color of the mold starting at the ear tip.
- Mold may be very pale in some cases, causing it to be confused with other ear rots.
  - » *Gibberella* almost always begins at the ear tip and progresses from there.
  - » *Fusarium* is usually scattered throughout the ear or localized on injured kernels.
  - » *Diplodia* usually starts at the base of the ear, is gray rather than pink, and husks may be “bleached.”

- Early, severely infected ears may rot completely, with husks adhering tightly to the ear and the mold growing between the husks and ear.
- Perithecia, or black fungal fruiting structures, may be lightly attached to kernel surface.

## MYCOTOXINS

- *Gibberella zeae* can produce two mycotoxins in the infected kernels: deoxynivalenol and zearalenone.
- These mycotoxins can be harmful to many monogastric animals, especially swine.
- Mycotoxin contamination of grain may or may not accompany ear mold symptoms.



**Figure 2.** Ear of corn showing gibberella infection.

## MANAGEMENT

- Scout fields before harvest in order to make informed decisions about harvest timing, postharvest grain handling, storage and utilization.
- Fields with significant infestations of *Gibberella* ear rot should be harvested as early as possible and handled separately.
- Set combine to reduce kernel damage and remove fines and shriveled or broken kernels.
- Dry infected grain at high temperature to a moisture of 15% or less and monitor grain in storage to maintain its condition.
- Test grain for presence of mycotoxins and manage accordingly.



# Fusarium Ear Rot

Mark Jeschke, Ph.D., Pioneer Agronomy Manager

## DISEASE FACTS

- Fusarium rot is the most common fungal disease on corn ears.
- Caused by *Fusarium verticillioides* (previously known as *Fusarium moniliforme*) and several other *Fusarium* species.
- The causal organism survives on residue of corn and other plants, especially grasses.
- Infection can occur under a wide range of environmental conditions but is more severe when weather is warm and dry.
- Disease enters the ear primarily through wounds from hail or insect feeding.
- Airborne spores can germinate and grow down the silk channel to infect kernels.



**Figure 1.** Kernels showing "starburst" pattern typical of Fusarium infection.

## DISEASE SYMPTOMS

- Scattered or groups of kernels are typically affected.
- Mold may be white, pink or salmon-colored.
- Infected kernels may turn tan or brown.
- "Starburst" pattern often associated with the disease (light-colored streaks radiating from top of kernels where silks were attached - Figure 1).
- In severe infections, ears may be completely consumed by the fungus, leaving lightweight husks cemented to the kernels by mycelia.

## IMPACT ON CROP

- Infection can reduce grain quality and yield due to lower kernel size and test weight.
- If infection occurs early, some ears may not produce harvestable grain. Less damage results if ear is more developed when infection occurs.
- Fungal growth is most common during milk, dough and dent stages.
- Mycotoxins are not associated with this disease but some animals may reject infected feed.



**Figure 2.** Left: Bt ears – no insect feeding or disease symptoms. Right: Non-Bt ears – insect feeding allowed entry of Fusarium fungus with resulting symptoms.

## MANAGEMENT

- Since the disease enters the ear primarily through injury and insect feeding, hybrids with one or more aboveground insect protection traits can have a lower risk of Fusarium ear rot.
- Hybrids differ in their susceptibility to fusarium ear rot. If Fusarium ear rot has caused significant damage in the past, growers should consider planting only hybrids with a Fusarium ear rot rating of 5 or higher.

### Harvest and Storage

- Clean bins before storage.
- Harvest at 25% moisture and dry to 15% moisture or lower if storing grain into the following summer.
- Cool infected grain below 50° F as quickly after harvest as possible and store at 30° F.
- Clean grain before storing to remove infected kernels, cobs and fines.
- Store infected grain separately, if possible.

# Corn Biomass Sampling Update:

## Nitrogen Content

Matt Clover, Ph.D., Agronomy Manager

### KEY FINDINGS

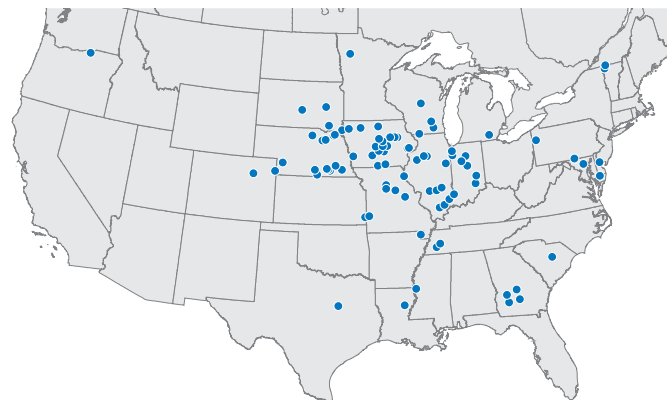
- Total nitrogen content of corn (lbs/acre) increased as corn grain yield increased.
- Data suggest that at least 20% of total nitrogen uptake occurred following tasseling.
- During grain fill, nitrogen supplied to the ear was 65% remobilized from vegetative tissue and 35% from soil uptake.

### OBJECTIVES

- A study was conducted during the 2021 and 2022 growing seasons in which corn biomass samples were collected from numerous on-farm locations across the U.S.
- The objective of this study was to evaluate corn biomass accumulation and nutrient content and their relationships with corn yield.
- This summary presents findings regarding nitrogen content and corn yield.

### STUDY DESCRIPTION

- Corn biomass samples were collected during the 2021 and 2022 growing seasons across 154 locations nationwide by Pioneer agronomists (Figure 1).
- Soil samples were taken from all locations prior to crop establishment.
- In-field biomass sampling points were selected at each location based on previous yield history to include areas with moderate and high yield potential.
- Representative whole plant samples were taken within each high and moderate yield area during the growing season.
- Plant samples were taken at V6, VT, and R5 growth stages:
  - » V6 (25 whole plant samples)
  - » VT (3 whole plant samples)
  - » R5 (3 whole plant samples)
- Samples were sent to Waypoint Analytical where dry weight was recorded, and samples were analyzed for nutrient concentrations.
- Yield was recorded at harvest for the moderate and high yield sampling areas at each location.
- Data were analyzed to determine total nutrient content.



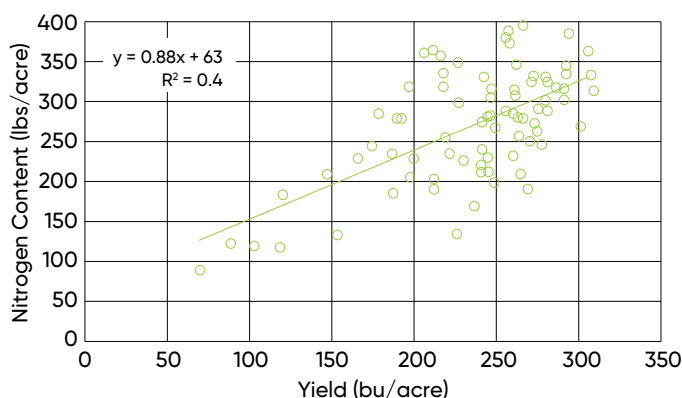
**Figure 1.** Corn biomass sampling locations in 2021 and 2022.

### RESULTS

- Management and soil characteristics for moderate and high yield sampling areas are summarized in Table 1.
- On average, high yield areas yielded 255 bu/acre and moderate yield areas yielded 218 bu/acre.
- Average soil phosphorous (P) and potassium (K) levels were both greater in higher yielding areas, however differences in soil pH were minimal.

**Table 1.** Management and soil nutrition of trial locations.

Yield Category	Yield	Plant Population	Soil P	Soil K	Soil pH
	bu/acre	plants/acre	ppm	ppm	
High	255	34,300	70	200	6.3
Moderate	218	33,700	55	192	6.5



**Figure 2.** Relationship between corn yield and total nitrogen content at R5 at locations sampled in the corn biomass study.

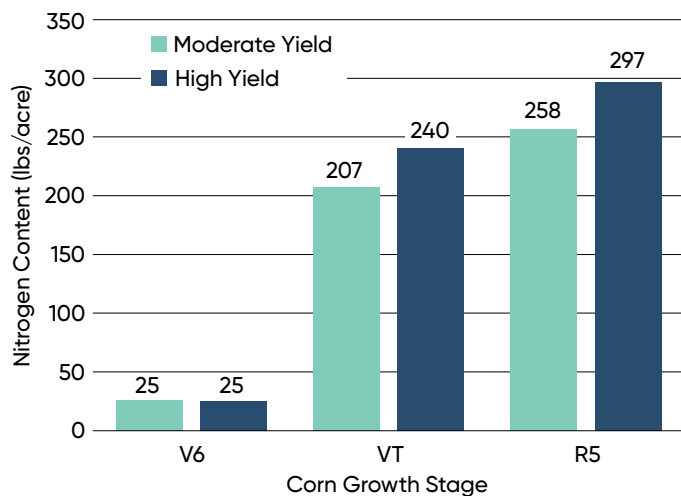


- o Biomass samples collected at the R5 growth stage showed that as corn grain yield increased, total nitrogen content increased as well (Figure 2).
- o Average nitrogen content by corn yield level is shown in Table 2.

**Table 2.** Average nitrogen content at R5 by corn yield level.

Corn Yield Level	Total Nitrogen Content
<i>bu/acre</i>	<i>lbs N/acre</i>
100	151
150	195
200	239
250	283
300	327

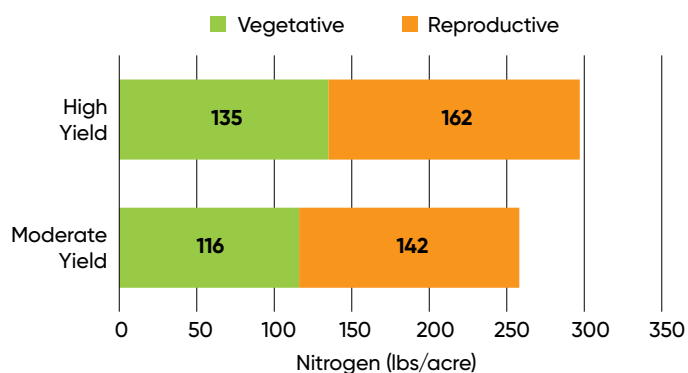
- o Total nitrogen content for the high yield areas was greater compared to the moderate yield areas at both the VT stage (33 lbs N/acre higher) and the R5 stage (45 lbs N/acre higher) (Figure 3).
- o Total nitrogen content at VT was 80% and 81% of that at R5 for the moderate and high yield areas, respectively.



**Figure 3.** Total nitrogen content per acre for corn in high and moderate yielding areas at three growth stages (V6, VT, R5).



- o The breakdown of nitrogen partitioning between vegetative and reproductive tissues at the R5 growth stage shows that considerable remobilization from the vegetative tissues to the ear occurred (Figure 4).
- o Nitrogen content of the vegetative tissues from VT to R5 decreased by 91 lbs N/acre and 105 lbs N/acre for the moderate and high yield areas, respectively.
- o If we assume no net loss of nitrogen from the vegetative tissue after VT, nitrogen uptake from the soil after VT was, at a minimum, 51 lbs N/acre for the moderate yield areas and 57 lbs N/acre for the high yield areas.
- o There was likely some nitrogen loss through senescence of lower leaves (which was not measured in this study), so the actual quantities of post-tasseling nitrogen uptake would likely have been greater than these figures.



**Figure 4.** Nitrogen partitioning between the vegetative and reproductive plant parts at the R5 growth stage.

# Corn Biomass Sampling Update: Potassium Content

Matt Essick, Agronomy Manager

## KEY FINDINGS

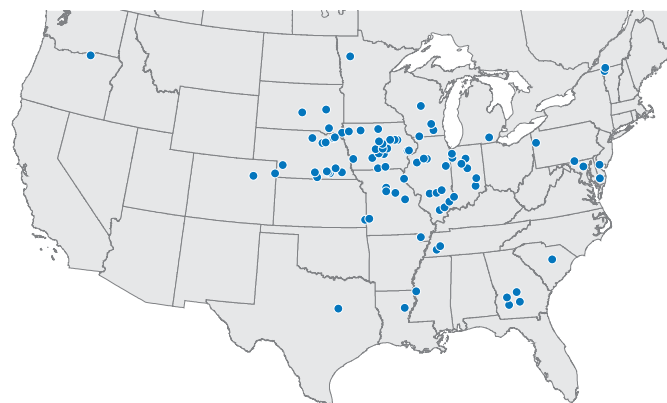
- Total potassium content of corn was greater in higher yield areas than moderate yield areas at V6 and VT, but not as much at R5.
- More potassium was removed in the grain in the moderate yield areas of the fields than in the high yield areas.

## OBJECTIVES

- A study was conducted during the 2021 and 2022 growing seasons in which corn biomass samples were collected from numerous on-farm locations across the U.S.
- The objective of this study was to evaluate corn biomass accumulation and nutrient content and their relationships with corn yield.
- This summary presents findings regarding potassium content and corn yield.

## STUDY DESCRIPTION

- Corn biomass samples were collected during the 2021 and 2022 growing seasons across 154 locations nationwide by Pioneer agronomists (Figure 1).
- Soil samples were taken from all locations prior to crop establishment.
- In-field biomass sampling points were selected at each location based on previous yield history to include areas with moderate and high yield potential.
- Representative whole plant samples were taken within each high and moderate yield area during the growing season.
- Plant samples were taken at V6, VT, and R5 growth stages:
  - » V6 (25 whole plant samples)
  - » VT (3 whole plant samples)
  - » R5 (3 whole plant samples)
- Samples were sent to Waypoint Analytical, where dry weight was recorded and samples were analyzed for nutrient concentrations.
- Yield was recorded at harvest for the moderate and high yield sampling areas at each location.
- Data were analyzed to determine total nutrient content.



**Figure 1.** Corn biomass sampling locations in 2021 and 2022.

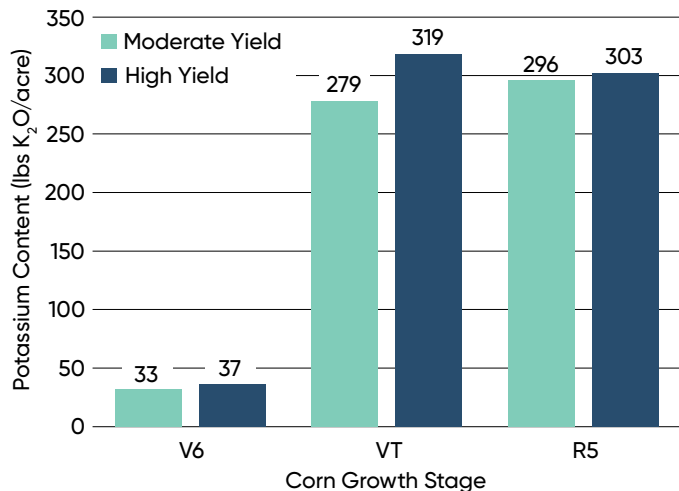
## RESULTS

- Management and soil characteristics for moderate and high yield sampling areas are summarized in Table 1.
- On average, high yield areas yielded 255 bu/acre and moderate yield areas yielded 218 bu/acre.
- Soil potassium averaged 200 ppm in high yield areas and 192 ppm in moderate yield areas.

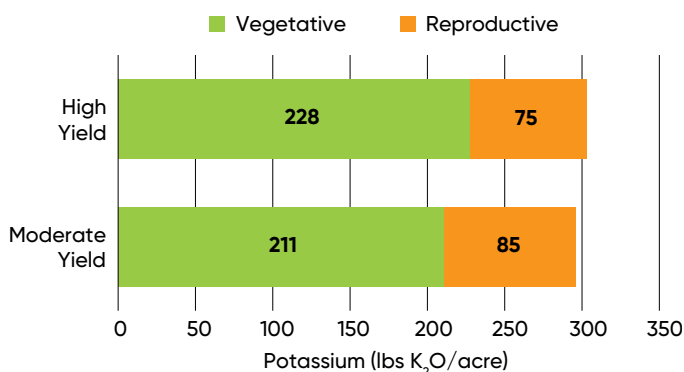
**Table 1.** Management and soil nutrition of trial locations.

Yield Category	Yield	Plant Population	Soil P	Soil K	Soil pH
	<i>bu/acre</i>	<i>plants/acre</i>	<i>ppm</i>	<i>ppm</i>	
High	255	34,300	70	200	6.3
Moderate	218	33,700	55	192	6.5

- Total potassium content of corn was greater in high yield areas than in moderate yield areas at all three sample timings, although the difference narrowed at R5 compared to the V6 and VT timings (Figure 2).
- Averaged across yield levels, total potassium content did not increase between VT and R5, which is likely due to additional potassium uptake during this timeframe being offset by potassium loss through the senescence of lower leaves.
  - » These results also suggest that a significant proportion of potassium in the grain was remobilized from other plant parts.
  - » Potassium is highly mobile in the plant and known to readily remobilize during grain fill.

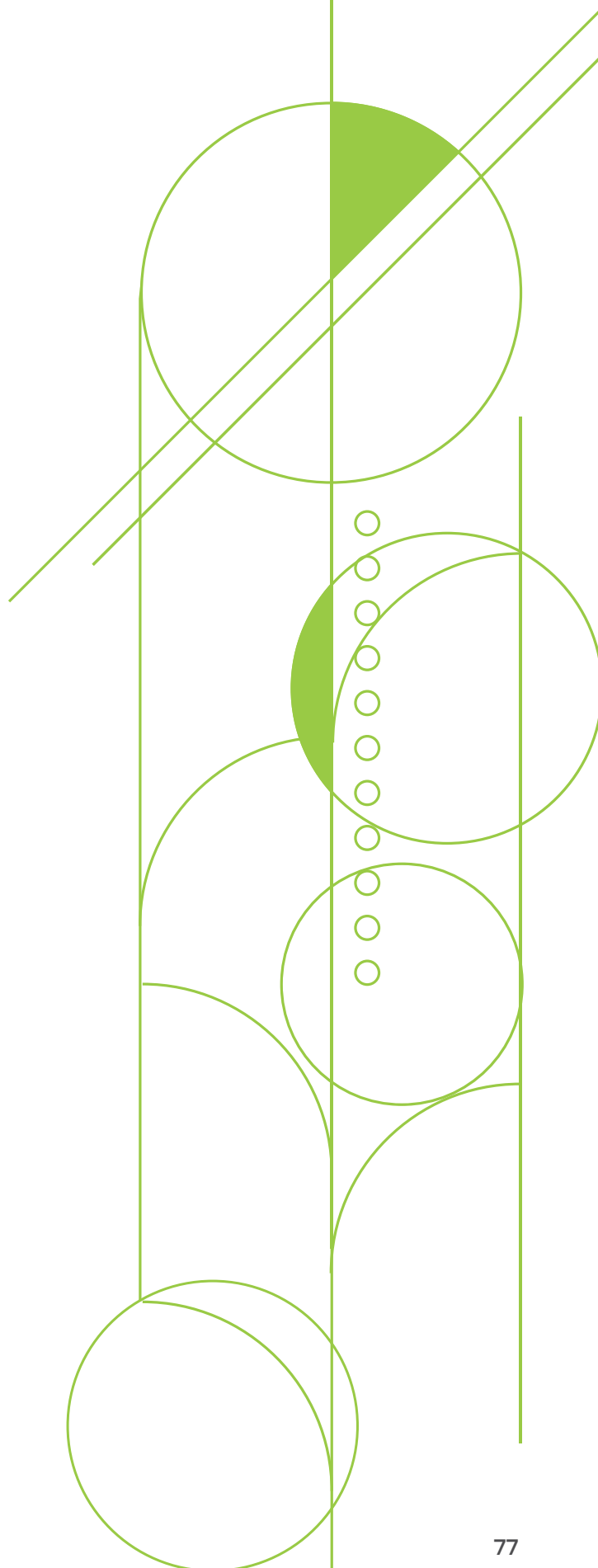


**Figure 2.** Total potassium content per acre for corn in high and moderate yielding areas at three growth stages (V6, VT, R5).



**Figure 3.** Potassium partitioning between the vegetative and reproductive plant parts at the R5 growth stage.

- o Potassium (K<sub>2</sub>O) content of reproductive tissues (including grain and cob) for high yield areas averaged 75 lbs/acre, compared to 85 lbs/acre for moderate yield areas (Figure 3).
- o Potassium is critical for regulating stomatal function in plants. The greater potassium partitioning to vegetative tissues in high yield areas compared to moderate yield areas could be due to greater demand in vegetative tissues of highly productive plants.



# Corn Biomass Sampling Update: Sulfur Content

Danny Brummel, M.S., Agronomic Resource Manager

## KEY FINDINGS

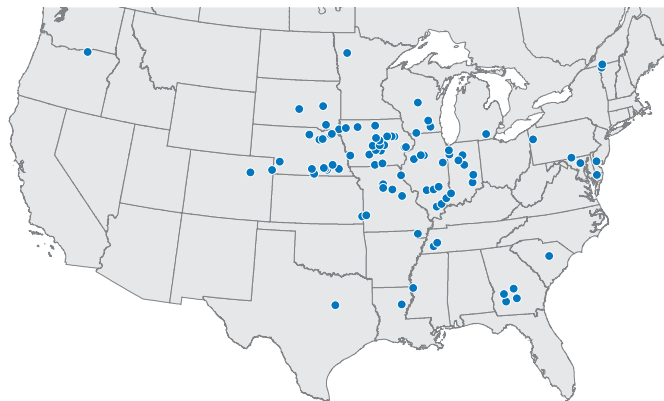
- Total sulfur content increased as corn grain yield increased.
- Sulfur content was similar between moderate and high yielding areas at V6, but higher yielding areas took up more sulfur during subsequent growth stages.
- 95% of total sulfur uptake occurred after early vegetative growth stages (post V6).

## OBJECTIVES

- A study was conducted during the 2021 and 2022 growing seasons in which corn biomass samples were collected from numerous on-farm locations across the U.S.
- The objective of this study was to evaluate corn biomass accumulation and nutrient content and their relationships with corn yield.
- This summary presents findings regarding sulfur content and corn yield.

## STUDY DESCRIPTION

- Corn biomass samples were collected during the 2021 and 2022 growing seasons across 154 locations nationwide by Pioneer agronomists (Figure 1).
- Soil samples were taken from all locations prior to crop establishment.
- In-field biomass sampling points were selected at each location based on previous yield history to include areas with moderate and high yield potential.
- Representative whole plant samples were taken within each high and moderate yield area during the growing season.
- Plant samples were taken at V6, VT, and R5 growth stages:
  - » V6 (25 whole plant samples)
  - » VT (3 whole plant samples)
  - » R5 (3 whole plant samples)
- Samples were sent to Waypoint Analytical where dry weight was recorded, and samples were analyzed for nutrient concentrations.
- Yield was recorded at harvest for the moderate and high yield sampling areas at each location.
- Data were analyzed to determine total nutrient content.



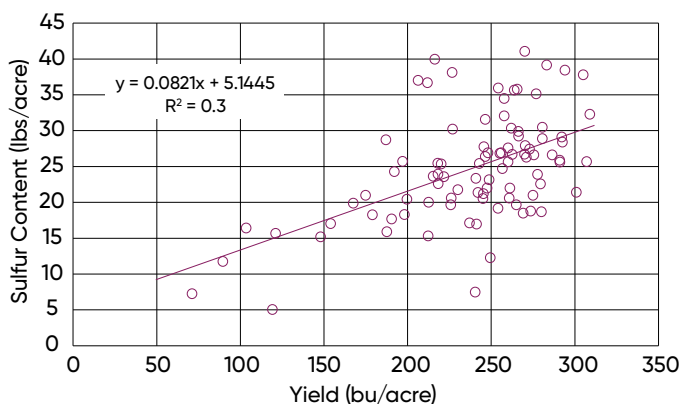
**Figure 1.** Corn biomass sampling locations in 2021 and 2022.

## RESULTS

- Management and soil characteristics for moderate and high yield sampling areas are summarized in Table 1.
- On average, high yield areas yielded 255 bu/acre and moderate yield areas yielded 218 bu/acre.
- Differences in soil properties (OM, pH) were minimal between high and moderate yield categories.

**Table 1.** Management and soil nutrition of trial locations.

Yield Category	Yield	Plant Population	Soil S	Soil OM	Soil pH
	<i>bu/acre</i>	<i>plants/acre</i>	<i>SO<sub>4</sub> ppm</i>	<i>%</i>	
High	255	34,300	12.9	3.4	6.3
Moderate	218	33,700	13.6	3.4	6.5



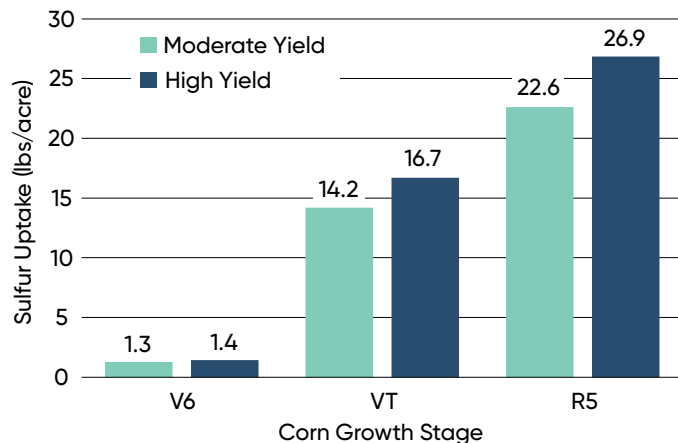
**Figure 2.** Relationship between corn yield and total sulfur content at R5 at locations sampled in the corn biomass study.

- o Biomass samples collected at the R5 growth stage showed that as corn grain yield increased, total sulfur content increased as well (Figure 2).
- o As corn yields exceed 200 bu/acre estimated total sulfur content exceeds 20 lbs/acre (Table 2).

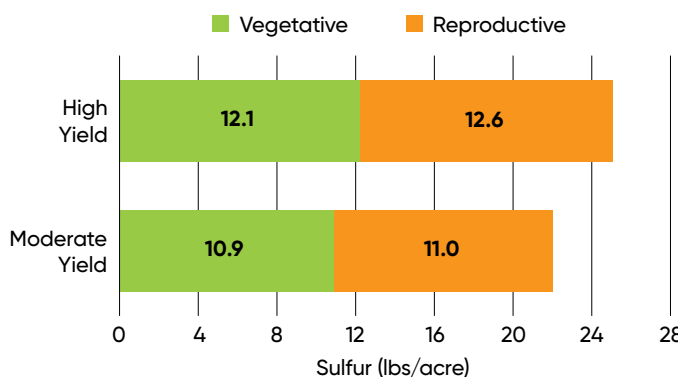
**Table 2.** Average sulfur content at R5 by corn yield level.

Corn Yield Level		Total Sulfur Content
bu/acre		lbs S/acre
100		13.4
150		17.5
200		21.6
250		25.7
300		29.8

- o Figure 3 shows average sulfur content by growth stage for samples collected from moderate and high yielding areas.
- o Sulfur content was similar between moderate and high yielding areas at V6, but higher yielding areas took up more sulfur during subsequent growth stages.
- o Very little sulfur uptake occurred prior to the V6 growth stage – 5% or less of the total uptake (Figure 3).
- o Total sulfur content at VT was 63% and 62% of that at R5 for the moderate and high yield areas, respectively.
- o If we assume no net loss of sulfur from the vegetative tissue after VT, sulfur uptake from the soil after VT was, at a minimum, 8.4 lbs S/acre for the moderate yield areas and 10.2 lbs S/acre for the high yield areas.
- o There was likely some sulfur loss through senescence of lower leaves (which was not measured in this study), so the actual quantities of post-tasseling sulfur uptake would likely have been greater than these figures.



**Figure 3.** Total sulfur content per acre for moderate and high yielding areas at three growth stages (V6, VT, R5).



**Figure 4.** Sulfur partitioning between the vegetative and reproductive plant parts at the R5 growth stage.

- o Sulfur content at R5 was slightly greater in the reproductive tissues (including grain and cob) than vegetative tissues (Figure 4).
- o Sulfur partitioning was similar in moderate and high yield areas.



# Corn Plant Nutrient Content Ratios Under Moderate and High Yields

Mary Gumz, Ph.D., Agronomy Manager

## KEY FINDINGS

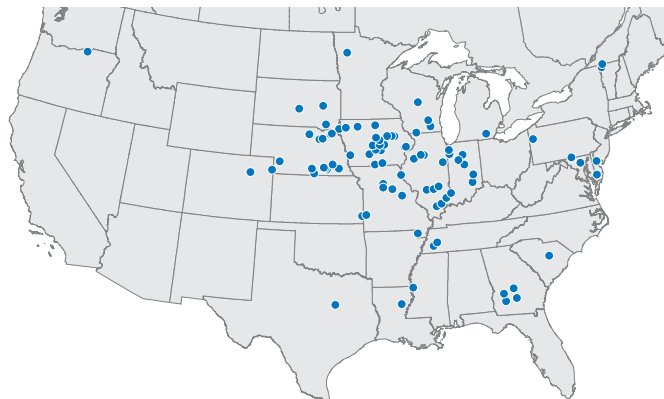
- Corn plant nutrient content (lbs/acre) was generally greater in higher yielding areas, with the greatest difference in nutrient content between yield levels at the VT stage.
- Ratios of nitrogen to sulfur and nitrogen to potassium at the R5 growth stage were around 11:1 and 1:1, respectively.
- There was no indication that the ratio of nitrogen to sulfur or nitrogen to potassium changed with yield level.

## OBJECTIVES

- A study was conducted during the 2021 and 2022 growing seasons in which corn biomass samples were collected from numerous on-farm locations across the U.S.
- The objective of this study was to evaluate corn biomass accumulation and nutrient content and their relationships with corn yield.
- This summary presents findings regarding ratios of nitrogen content to sulfur and potassium content at moderate and high yield levels.

## STUDY DESCRIPTION

- Corn biomass samples were collected during the 2021 and 2022 growing seasons across 154 locations nationwide by Pioneer agronomists (Figure 1).
- Soil samples were taken from all locations prior to crop establishment.
- In-field biomass sampling points were selected at each location based on previous yield history to include areas with moderate and high yield potential.
- Representative whole plant samples were taken within each high and moderate yield area during the growing season.
- Plant samples were taken at V6, VT, and R5 growth stages:
  - » V6 (25 whole plant samples)
  - » VT (3 whole plant samples)
  - » R5 (3 whole plant samples)
- Samples were sent to Waypoint Analytical where dry weight was recorded, and samples were analyzed for nutrient concentrations.
- Yield was recorded at harvest for the moderate and high yield sampling areas at each location.
- Data were analyzed to determine total nutrient uptake.



**Figure 1.** Corn biomass sampling locations in 2021 and 2022.

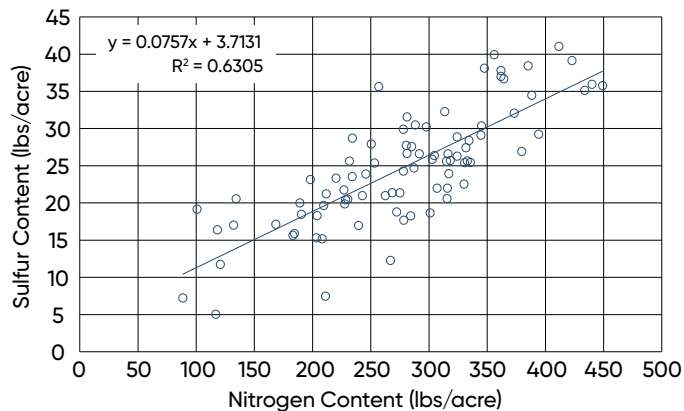
## RESULTS

- On average, high yield areas yielded 255 bu/acre and moderate yield areas yielded 218 bu/acre (data not shown).
- Corn plant nutrient content (lbs/acre) was generally greater in higher yielding areas, with the greatest difference in nutrient content between yield levels at the VT growth stage (Table 1).
  - » One notable exception was nitrogen content at the V6 growth stage, which did not differ by yield level.
  - » At the R5 stage, the difference in potassium content between yield levels diminished to considerably less than that measured at VT.
  - » Average content of nitrogen, potassium and sulfur for the two yield level groupings at VT was roughly proportional to average yield.

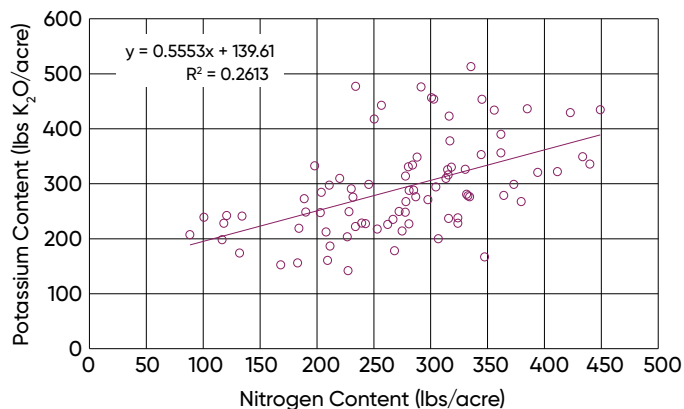
**Table 1.** Nitrogen (N), sulfur (S) and potassium (K) content of the aboveground portion of the plant by growth stage at moderate and high yield levels.

Growth Stage	V6		VT		R5	
	Mod	High	Mod	High	Mod	High
————— lbs/acre —————						
N	25	25	207	240	258	297
K	33	37	279	319	296	303
S	1.3	1.4	14	17	23	27



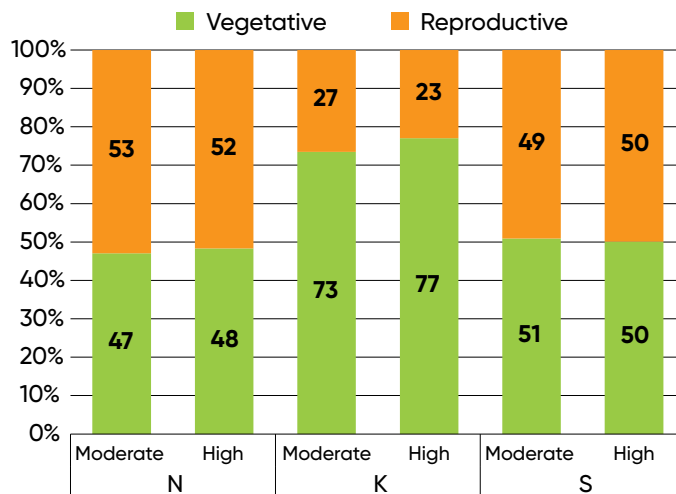


**Figure 2.** Relationship between whole plant nitrogen and sulfur content at the R5 growth stage.



**Figure 3.** Relationship between whole plant nitrogen and potassium content at the R5 growth stage.

- The ratio of nitrogen to sulfur at the R5 growth stage was around 11:1 (Figure 2).
- The ratio of nitrogen to potassium at the R5 growth stage increased with higher nitrogen content but was around 1:1 in the middle part of the observed range (Figure 3).
- The relationship of nitrogen to sulfur was stronger than that of nitrogen to potassium, which tended to be more variable.
- There was no indication that the ratio of nitrogen to sulfur or nitrogen to potassium changed with yield level.
- Partitioning of nitrogen and sulfur between vegetative and reproductive plant parts did not differ between yield levels (Figure 4).
- Partitioning of potassium was slightly greater for vegetative tissues at higher yield levels.



**Figure 4.** Partitioning of nitrogen, potassium, and sulfur between vegetative and reproductive (grain and cob) tissues at R5.



# Corn Response to High pH Soil Environments:

Northwestern Kansas, Southwestern Nebraska, and Northeastern Colorado

Mike Kriegshauser, Strategic Account Manager; Aaron Vammer, Field Agronomist; Dalton Kampsen, Former Field Agronomist; Matt McKenzie, Field Agronomist; and Cody Sullivan, Seed Territory Manager

## KEY FINDINGS

- High soil pH can limit the uptake of several nutrients, which can be detrimental to corn yield.
- Four years of Pioneer field trials showed that corn hybrids can vary in their response to high soil pH under different soil organic matter levels.
- Some products showed visual symptoms (yellowing) associated with high soil pH but still maintained yield.

## HIGH SOIL PH CAN LIMIT CORN YIELDS

- Alkaline or high pH (>7) soils are naturally occurring in parts of the western Corn Belt, including northwestern Colorado, southwestern Nebraska, and northwestern Kansas.
- High soil pH can limit the uptake of several nutrients, such as phosphorous, zinc, iron, manganese, boron, and copper.
- Corn hybrids can respond differently to high soil pH as indicated by the presence of iron chlorosis (Figure 1).
- Corn response to high soil pH may differ based on soil organic matter levels.



**Figure 1.** Severe iron chlorosis in a corn hybrid in low organic matter soil.

## CORN HYBRID EVALUATION IN HIGH PH SOILS

- Pioneer conducts field trials to evaluate corn hybrid performance in calcareous soil environments with various organic matter levels.
- Information gained from these trials helps drive better product placement recommendations for high soil pH fields.

## FIELD RESEARCH METHODS

- Trials were placed on soils with a historic high pH (>7.9) where iron chlorosis symptoms were likely to be observed (Figure 3).
- Soil samples were taken across high pH locations to determine actual pH and organic matter levels.
- Field observations were collected at 16 locations across northeast Colorado, southwest Nebraska and northwest Kansas over a four-year period.



**Figure 2.** Visual differences in early season chlorosis among Pioneer® brand corn products in high pH soil.

- Observations were collected early in the season (V6-V8) as well as late in the season (R1-R3). Yields were collected in most of these locations.
- Pioneer® brand corn products were evaluated based on color (chlorosis) and yield.
- A three-category rating system was used to rate response to high soil pH: S = Strength, A = Acceptable, and C = Consideration.
- Observations were combined, and a final rating was assigned to each corn product for calcareous high pH soils.

## RESULTS

- Pioneer brand corn products responded differently to high pH calcareous soils with varying levels of organic matter.
- Some products showed visual symptoms (yellowing) associated with high pH soil but still maintained yield across the field.



**Figure 3.** Hybrid plot within a high pH area of the field.

**Table 1.** Corn product suitability to calcareous high pH soils.

Hybrid/Brand <sup>1</sup>	Visual Crop Color	Overall Suitability
P9193 <sub>Q</sub> ™ (Q, LL, RR2)	A	A
P9466 <sub>AML</sub> ™ (AML, LL, RR2)	S	S
P9489 <sub>Q</sub> ™ (Q, LL, RR2)	A	A
P9551 <sub>Q</sub> ™ (Q, LL, RR2)	A	A
P9955 <sub>Q</sub> ™ (Q, LL, RR2)	A	S
P9998 <sub>Q</sub> ™ (Q, LL, RR2)	A	S
P0075 <sub>Q</sub> ™ (Q, LL, RR2)	S	S
P0157 Family	A	A
P0339 <sub>Q</sub> ™ (Q, LL, RR2)	A	A
P0404 <sub>Q</sub> ™ (Q, LL, RR2)	C	C
P0487 <sub>Q</sub> ™ (Q, LL, RR2)	A	A
P0622 <sub>Q</sub> ™ (Q, LL, RR2)	A	A
P0817 <sub>Q</sub> ™ (Q, LL, RR2)	A	S
P0859 <sub>AM</sub> ™ (AM, LL, RR2)	A	S
P0908 <sub>AML</sub> ™ (AML, LL, RR2)	A	S
P0924 <sub>Q</sub> ™ (Q, LL, RR2)	S	A
P0995 <sub>AM</sub> ™ (AM, LL, RR2)	A	A
P1089 <sub>AMXT</sub> ™ (AMXT, LL, RR2)	A	A
P1122 <sub>AML</sub> ™ (AML, LL, RR2)	A	S
P1164 <sub>AM</sub> ™ (AM, LL, RR2)	A	S
P1170 <sub>AM</sub> ™ (AM, LL, RR2)	A	S
P1278 <sub>Q</sub> ™ (Q, LL, RR2)	S	S
P1359 <sub>AM</sub> ™ (AM, LL, RR2)	S	S
P1366 <sub>Q</sub> ™ (Q, LL, RR2)	A	S
P1548 <sub>AM</sub> ™ (AM, LL, RR2)	A	A
P1587 <sub>Q</sub> ™ (Q, LL, RR2)	A	A
P1718 <sub>AML</sub> ™ (AML, LL, RR2)	A	A
P1742 <sub>Q</sub> ™ (Q, LL, RR2)	S	S
P1828 <sub>Q</sub> ™ (Q, LL, RR2)	S	A
P1847 <sub>AML</sub> ™ (AML, LL, RR2)	A	A
P2042 <sub>AML</sub> ™ (AML, LL, RR2)	A	A

Legend: S=Strength, A=Acceptable, C=Consideration

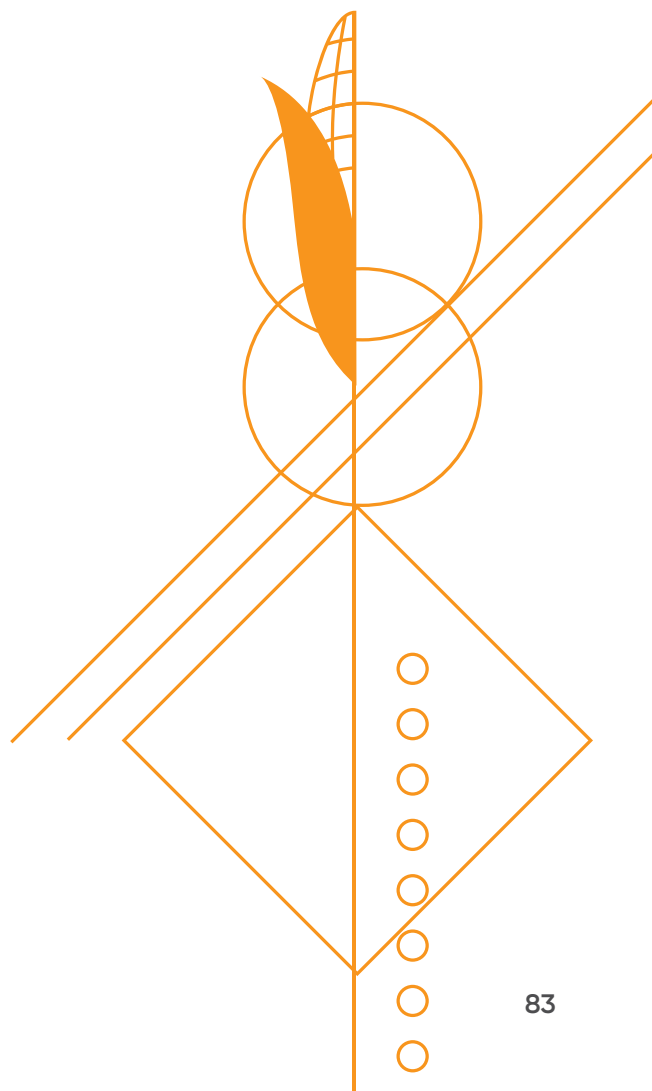
- o Performance ratings of Pioneer® brand products in calcareous high pH soils based on results of this study are shown in Table 1.
  - » S = Strength – tolerates the condition better than other Pioneer brand products observed in the same environment.
  - » A = Acceptable – has an average tolerance to the condition relative to other Pioneer brand products observed in the same environment.
  - » C = Consideration – the hybrid is less tolerant of the environment relative to other Pioneer brand products observed. Consider another product choice.

### FACTORS IN SELECTING A CORN PRODUCT:

- o Select corn products that show optimum yield performance.
- o Select corn products that can maintain acceptable plant and ear height.
- o Select corn products that can tolerate elevated soil pH levels.
- o Visit with your local Pioneer sales representative or dealer for information on Pioneer brand corn product options.

## CONCLUSIONS AND MANAGEMENT CONSIDERATIONS

- o Management practices for high pH soils include:
  - » Aggressive utilization of starter fertilizer.
  - » Manure application to areas with known micronutrient issues.
  - » Limit early water applications, if possible, to keep soils from sealing over.



# Carbon, Oxygen, and Hydrogen Fertility and Corn Grain Yield

Stephen Strachan, Ph.D., Research Agronomist

## KEY POINTS

- Carbon, oxygen, and hydrogen comprise approximately 94% of the dry weight of the corn plant.
- Plants acquire these three elements from water and the atmosphere.
- The key to managing these essential nutrients is to manage soil water.

## ELEMENTAL COMPOSITION OF CORN PLANTS

Carbon, oxygen, and hydrogen are considered “freebie” nutrients because they do not need to be applied as fertilizer in crop production. These three nutrients comprise approximately 94% of the dry weight of the corn plant (carbon – 44%; oxygen – 45%; and hydrogen – 6%) (Figure 1) (Latshaw and Miller, 1924). Yet they are hardly ever considered in a corn fertility program. Carbon, oxygen, and hydrogen are principal components of starch, protein, oil, and fiber, which comprise about 85% of the final grain yield. The remaining 15% is water. What can corn producers do to increase carbon, oxygen, and hydrogen uptake? This Field Facts article discusses the sources of carbon, oxygen, and hydrogen and considers management options to increase uptake of these essential nutrients.

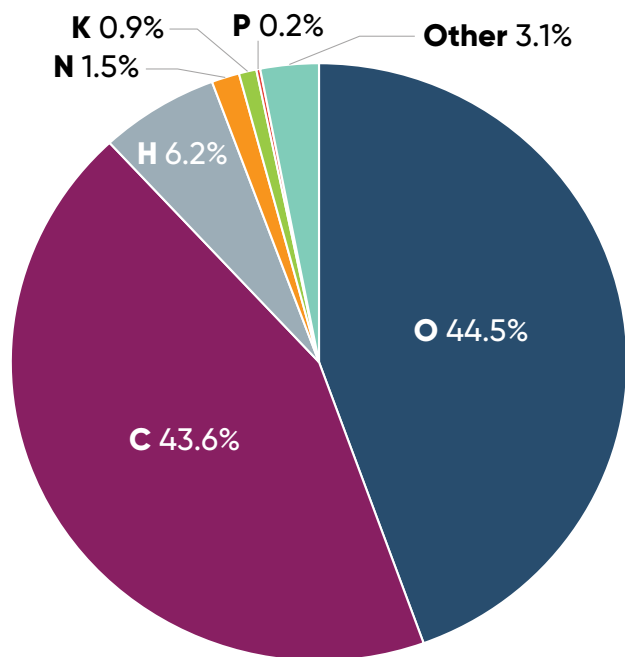


Figure 1. Elemental composition of corn plant dry weight.

## SOURCES OF CARBON, OXYGEN, AND HYDROGEN

### Carbon

Carbon is extracted from carbon dioxide ( $\text{CO}_2$ ) in the atmosphere. Photosynthesis converts low-energy carbon-oxygen (C-O) bonds primarily to higher energy carbon-hydrogen (C-H) and carbon-carbon (C-C) bonds in sugars, starch, oil, amino acids, and other organic compounds. From a fertility perspective,  $\text{CO}_2$  is an unlimited resource in the atmosphere, so we do not need to fertilize corn with carbon. Carbon is and will continue to be a “freebie” nutrient.

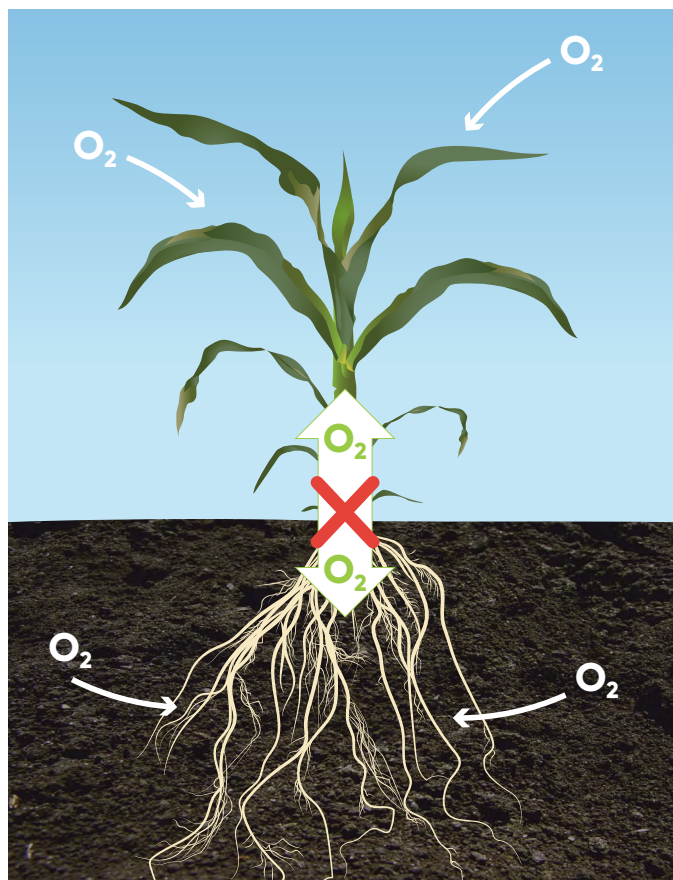


Figure 2. Sources of oxygen for the corn plant. Shoots extract oxygen from the air, while roots extract oxygen from the soil atmosphere. Very little oxygen translocates between corn shoots and roots.

### Oxygen

There are three sources of oxygen ( $\text{O}_2$ ). The first source is molecular oxygen extracted from the air or from the soil atmosphere. Mitochondria in corn plant cells require oxygen to function properly to produce energy. Mitochondria in corn

shoot cells consume oxygen extracted from the air while mitochondria in corn root cells consume oxygen extracted from the soil atmosphere. Transport of oxygen from corn shoots to corn roots is very limited and insufficient to meet root demand because water can dissolve only very low amounts of oxygen (Figure 2).

The second source is oxygen extracted from water as water molecules are split during photosynthesis (Figure 3). The vast majority of this oxygen is released into the atmosphere as molecular oxygen. However, a low percentage of oxygen molecules could be consumed by plant mitochondria to generate energy during mitochondrial respiration.



**Figure 3.** Photosynthesis converts carbon dioxide and water into sugar and oxygen.

The third source is oxygen contained in carbon dioxide (CO<sub>2</sub>) (Salisbury and Ross, 1978). During photosynthesis, this oxygen is incorporated into sugar, which is the starting material for all plant organic compounds. This is the oxygen that contributes to yield.

### Hydrogen

The source for essentially all hydrogen in the corn plant is hydrogen extracted from water (Figure 3). During photosynthesis, as plant cells assimilate oxygen extracted from CO<sub>2</sub> into sugar, these cells also assimilate hydrogen, extracted from water, into sugar. Approximately 91% of corn grain dry matter is derived from air and water.

## CARBON, OXYGEN, AND HYDROGEN UPTAKE

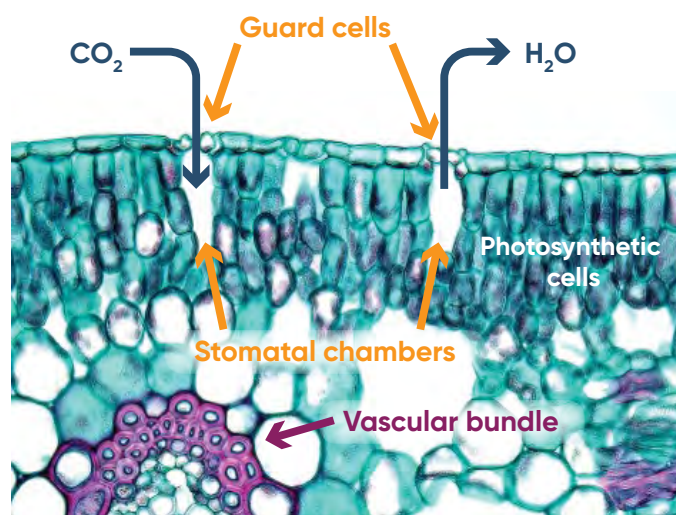
The key to managing these essential nutrients is to manage soil water. If the soil contains too much water, mitochondria in the corn root cells suffocate from lack of oxygen and die, leading to overall root death. The soil atmosphere contains up to about 21% oxygen, whereas the solubility of oxygen in water is about 6 to 12 parts per million. Oxygen in the soil atmosphere in a well-aerated soil is about 30 times more available to the corn root than oxygen in a water-saturated soil.

If the soil contains too little water, evapotranspiration is limited, plant stomates close, and very little carbon dioxide and oxygen are captured in stomatal chambers (Figure 4). Reduced carbon dioxide levels limit the amount of carbon that is converted into sugar, and reduced oxygen levels inhibit mitochondrial respiration for energy production. Limitations of both functions reduce grain yield. When the corn plant is transpiring properly, stomates are open to allow for release of water vapor into the atmosphere. These open stomates also allow CO<sub>2</sub> and O<sub>2</sub> to move from the atmosphere into stomatal chambers. As stomates close to conserve water during dry conditions, these closed stomates also restrict the capture of CO<sub>2</sub> and O<sub>2</sub>.



Managing water in the soil is like managing the oil in your tractor engine. As long as you maintain the oil level between the “full” and the “add” marks on the dipstick, oil pressure is suitable for proper engine function. For water, as long as the water content in the soil is greater than the wilting point and is at or less than field capacity, corn grows properly. Management practices to better ensure maximum corn growth and yield include:

- Install tile drainage to more rapidly remove excess water during rainy periods.
- Manage soil tillage to create a soil structure that allows maximum water percolation and capture during and after rains or irrigation events.
- Improve the soil structure to allow better retention of water between rainfalls or irrigations.
- Conserve soil moisture by maintaining surface residue to reduce evaporation of water directly from the bare soil surface.
- Fertilize properly to allow the corn plant to efficiently capture all of the carbon it can.
- Select hybrids that perform well in drier environments.



**Figure 4.** Stomatal guard cells regulate the exchange of materials between the atmosphere and the corn plant. Proper soil moisture better ensures guard cells are open to allow for maximum uptake of CO<sub>2</sub> and other gases.

# Corn Response to Reduced Nitrogen Environments

## in a 17-Year Study

Mark Jeschke, Ph.D., Agronomy Manager

### KEY FINDINGS

- Pioneer conducted a nitrogen rate by crop rotation study in which nitrogen rate treatments were applied in the same locations of the field over multiple years.
- Corn grown in rotation with soybeans was generally able to yield better under reduced nitrogen rates than corn grown continuously.
- Yield of rotated corn with no applied nitrogen gradually recovered over time, with almost no yield loss observed after the 10th year of the study. This outcome is unusual and the reason for it is unknown.

### OBJECTIVE

- Beginning in 2006, Pioneer conducted an annual study to evaluate the response of corn in limited nitrogen environments.
- This study was unique in that each nitrogen rate treatment was positioned on precisely the same field area each year.
- This allowed researchers to examine corn response to each nitrogen level over multiple years of production.
- In addition, after many years of no added nitrogen, the “zero-N” treatment represented a truly nitrogen deficient environment.

### STUDY DESCRIPTION

- The reduced nitrogen study was conducted over multiple years between 2006 and 2014 at four Corteva agriscience research stations located in Corn Belt states (Table 1).
- The study at the Johnston, IA research station was maintained continuously up through 2022.
- The York, NE location was irrigated; all others were rain-fed.

**Table 1.** Reduced nitrogen study locations.

Study Locations	Years
Johnston, IA	2006–2022 <sup>a</sup>
Windfall, IN	2007–2014 <sup>b</sup>
Champaign, IL	2007–2014
York, NE	2008–2014

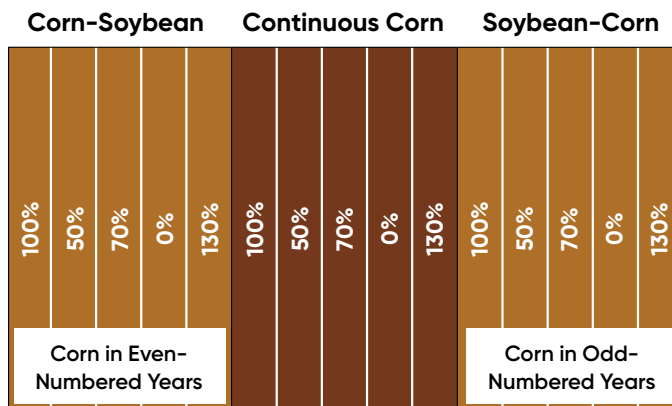
<sup>a</sup>Yield data not collected in 2012 (extreme drought), 2015 (wind damage), 2018 (flooding and wind damage), 2019 (flooding and wind damage), and 2020 (extreme wind damage).

<sup>b</sup>Yield data not collected in 2011 (flooding) and 2012 (extreme drought)



**Figure 1.** Reduced nitrogen study at Johnston, IA showing visible nitrogen deficiency symptoms in the low nitrogen rate treatments in the continuous corn block (June 11, 2009).

- Each location included two crop rotations and five nitrogen rates within each rotation for a total of 10 treatments:
  - Crop Rotations:**
    - » Continuous corn
    - » Corn-soybean rotation
  - Nitrogen Rates (% of full rate):**
    - » 0%, 50%, 70%, 100%, 130%
- Each location included two corn-soybean rotation blocks, so that corn yield from the rotation could be measured every year of the study (Figure 2). One block was planted to corn in even-numbered years and the other in odd-numbered years.



**Figure 2.** Plot layout of the reduced nitrogen study at Johnston, IA.

- For the first six years of the study, nitrogen rate treatments were based on a percentage of a “full-rate” treatment.
- The nitrogen rate considered to be a full-rate (100%) treatment differed among years and locations based on determinations of economically optimum rates for each site-year.
- Beginning in 2012, the study was changed to use a fixed set of nitrogen rates that were maintained continually at the Johnston, IA location through 2022. Actual nitrogen rates for the Johnston study are shown in Table 2.

**Table 2.** Nitrogen rates in lbs N/acre used in continuous corn and corn-soybean rotation in the reduced nitrogen study at Johnston, IA.

**Continuous Corn**

Percent of Full Rate	2006–2007	2008	2009	2010	2011	2012–2022
———— lbs N/acre ————						
0%	0	0	0	0	0	0
50%	76	92	74	90	100	75
70%	106	129	104	126	140	150
<b>100%</b>	<b>152</b>	<b>184</b>	<b>148</b>	<b>180</b>	<b>200</b>	<b>225</b>
130%	198	239	192	234	260	300

**Corn-Soybean Rotation**

Percent of Full Rate	2006–2007	2008	2009	2010	2011	2012–2022
———— lbs N/acre ————						
0%	0	0	0	0	0	0
50%	52	63	49	70	75	50
70%	73	88	69	98	105	100
<b>100%</b>	<b>104</b>	<b>126</b>	<b>98</b>	<b>140</b>	<b>150</b>	<b>150</b>
130%	135	164	127	182	195	200

- Nitrogen treatments were applied as a single application. Application timing varied from immediately after planting to approximately V2 stage depending on the location and year.
- Nitrogen was surface applied as ammonium nitrate during the first four years of the study and as stabilized urea from 2010 onward at all locations except York, NE where it was sidedressed as 28% UAN (Figure 3).
- Nitrogen fertilizer was applied by hand to ensure precise placement (Figure 4).
- Each rotation x nitrogen rate treatment plot was 8 rows wide (30-inch row spacing) and length varied by location. At Johnston, the plots were 122 ft long from 2006 through 2018 and 105 ft long from 2019 onward.



**Figure 4.** Visual nitrogen deficiency symptoms indicated that hand application of fertilizer was successful for achieving precise placement and establishment of nitrogen deficient environments.

- The corn hybrid used at a given location differed from year to year and was typically a Pioneer® brand corn leader product for that particular geography.
- In 2011, 2012, 2013, and 2014 the nitrogen rate treatments were split between two hybrids to determine whether the hybrids would respond differently to crop rotation and reduced nitrogen environments (Table 3).

**Table 3.** Pioneer® brand corn products used in the Johnston, IA reduced nitrogen study, 2007–2023.

Year(s)	Hybrid/Brand <sup>1</sup>
2007	34A20 (HXX,LL,RR2)
2008	34R67 (HX1,LL,RR2)
2009–2010	33M16 (HX1,LL,RR2)
2011	33T57 (HX1,LL,RR2), 34N42 (HX1,LL)
2012–2014	P1498 <sup>AM</sup> ™ (AM,LL,RR2), 33D53 <sup>AM</sup> ™ (AM,LL,RR2)
2015	P1498 <sup>AM</sup> ™ (AM,LL,RR2)
2016–2018	P1197 <sup>AM</sup> ™ (AM,LL,RR2)
2019–2020	P1093 <sup>Q</sup> ™ (Q,LL,RR2)
2021–2023	P1185 <sup>Q</sup> ™ (Q,LL,RR2)

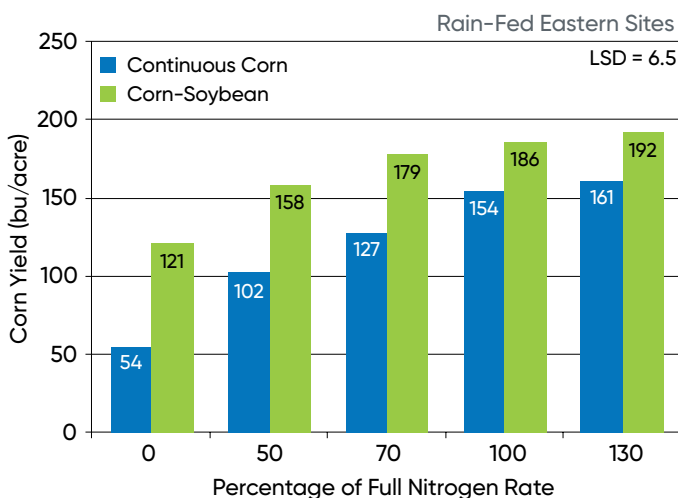


**Figure 3.** Stabilized urea (urea + DCD + NBPT) on the soil surface immediately after application. Johnston, IA, May 22, 2023.

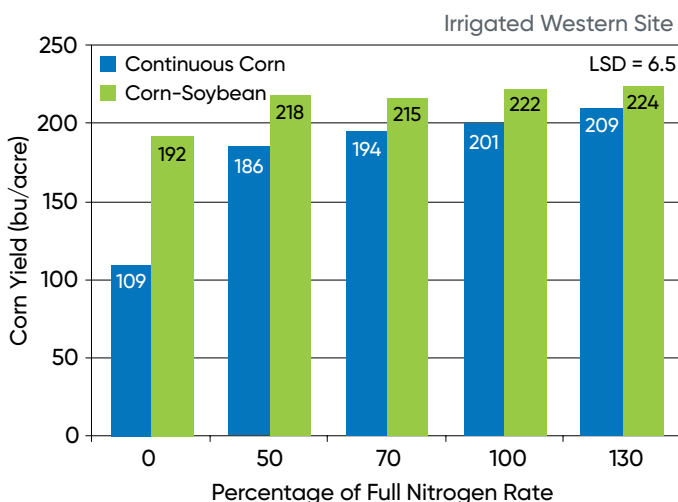
## RESULTS

### All Locations: 2006–2014

- Across all study locations, corn rotated with soybean had greater top-end yield and less yield penalty associated with reduced nitrogen fertilizer rates compared to continuous corn (Figure 5 and 6).
- Corn yield response to nitrogen rate differed between the rain-fed eastern sites (Johnston, Windfall, and Champaign) and the irrigated western site (York).
- The irrigated site had less of a yield penalty associated with reduced nitrogen rates compared to the rain-fed sites, particularly for rotated corn (Figure 6).
- In rotated corn, the average reduction in yield with zero nitrogen was 35% across the rain-fed sites, compared to only 14% at the irrigated site.
- In continuous corn, the average reduction in yield with zero nitrogen was 65% across the rain-fed sites, and 46% at the irrigated site.



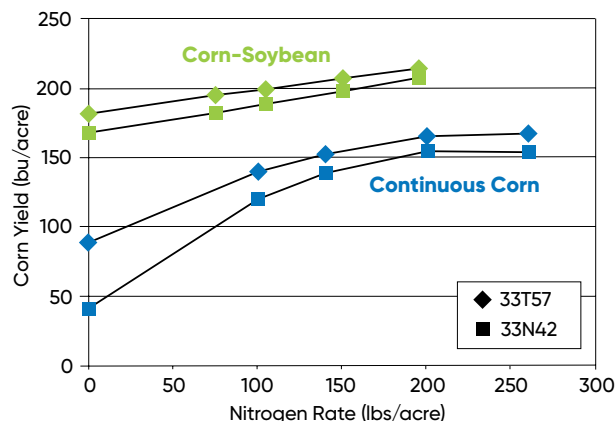
**Figure 5.** Influence of nitrogen rate and crop rotation on yield averaged over years (2006–2014) for rain-fed eastern sites (IA, IN, IL).



**Figure 6.** Influence of nitrogen rate and crop rotation on yield averaged over years (2008–2014) for the irrigated western site (NE).

### Hybrid Comparisons: 2011–2014

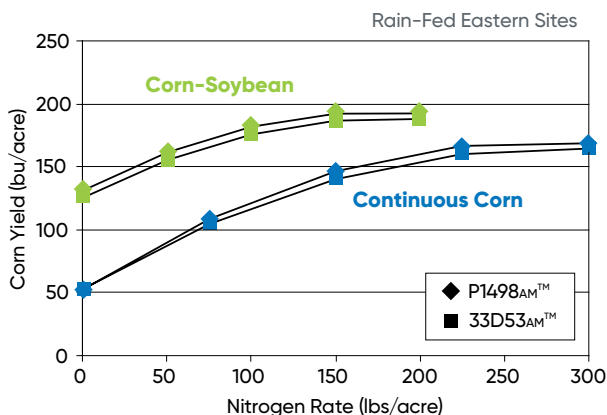
- The design of this study, with reduced nitrogen rate treatments maintained in the same locations for multiple years, provided the opportunity to compare hybrid performance in established nitrogen stress environments.
- Hybrid comparisons were first conducted in 2011, after each study location had been established for at least three years, and continued through 2014.
- Each eight-row nitrogen rate treatment strip was split into four rows of each hybrid, with the same two hybrids used across all sites.
- In 2011, Pioneer® hybrid 33T57 and 34N42 were compared in the study, based on previous Pioneer research which showed 33T57 to be more tolerant than 34N42 of low residual soil N levels, and less likely to lose yield under N stress.



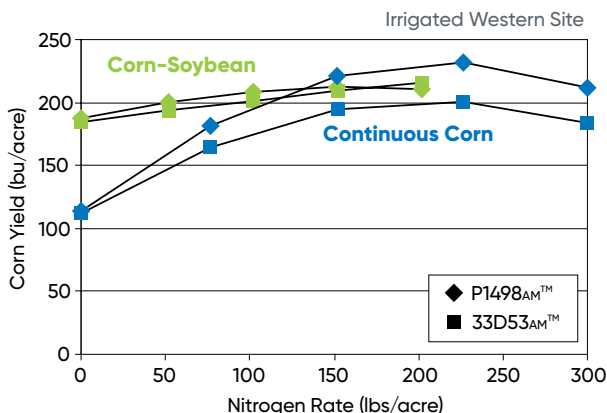
**Figure 7.** Response of Pioneer 33T57 and 34N42 to nitrogen rates under continuous corn and corn-soybean rotation, averaged across the Champaign, Johnston, and York sites.

- Pioneer 33T57 was higher yielding than 34N42 across all nitrogen rates in both rotations (Figure 7).
- In the corn-soybean rotation, both hybrids responded similarly to nitrogen rate, with yield increasing linearly up to the highest nitrogen rate.
- In continuous corn, the two hybrids diverged in their performance at the zero nitrogen rate, with Pioneer 33T57 showing greater yield stability than 34N42 under extreme nitrogen deficiency.
- In 2012, the hybrid comparison was repeated but with two different hybrids, Pioneer P1498AM™ and 33D53AM™ brand corn, with the former expected to show greater yield stability under nitrogen deficiency. This comparison was continued through 2014.
- Results differed between the eastern rain-fed sites and the western irrigated site.
- Across the eastern sites, yield response of the two hybrids to nitrogen rate was very similar in both rotated and continuous corn (Figure 8).
- At the irrigated site, P1498AM had a significant yield advantage over 33D53AM in continuous corn at the higher nitrogen rates.
- The hybrids responded similarly to nitrogen rate in rotated corn.





**Figure 8.** Response of Pioneer P1498<sub>AM</sub> and P33D53<sub>AM</sub> to nitrogen rates under continuous corn and corn-soybean rotation, averaged across the eastern rain-fed sites in 2012, 2013, and 2014 (Champaign, Windfall, and Johnston).

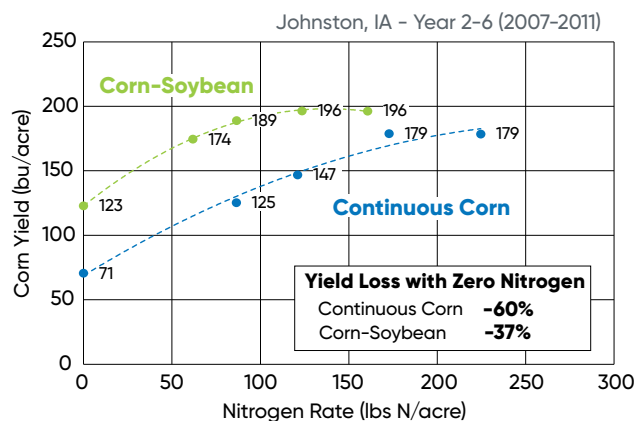


**Figure 9.** Response of Pioneer P1498<sub>AM</sub> and P33D53<sub>AM</sub> to nitrogen rates under continuous corn and corn-soybean rotation, at the western irrigated site in 2012, 2013, and 2014 (York, NE).

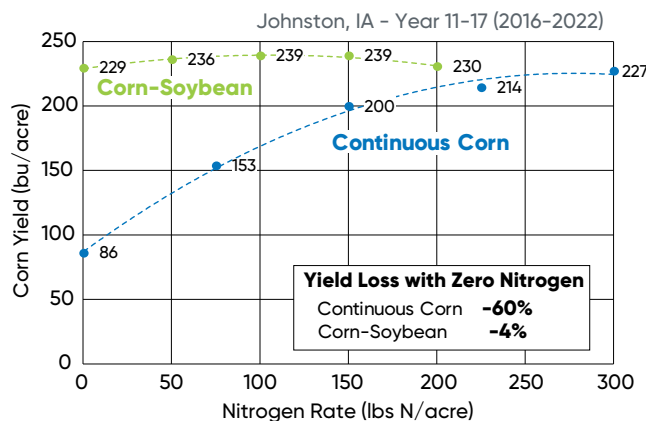
**Johnston, IA Long-Term Results: 2006-2022**

- The study was continued at the Johnston, IA site through 2022, providing the opportunity to look at long-term trends in corn yield response to reduced nitrogen environments.
- There were a few seasons in which the ability to collect quality yield data was compromised by severe weather damage, so results were grouped into two time periods: 2007-2011, which included an unbroken five-year stretch of yield data, and 2016-2022, which included four years of yield data from 2016, 2017, 2021, and 2022.
- During the 2007-2011 period, rotated corn had greater top-end yield and less yield penalty associated with reduced nitrogen rates compared to continuous corn (Figure 10).
- In the zero nitrogen treatment, yield was reduced by 60% in continuous corn and 37% in rotated corn.
- Yield of both rotated and continuous corn increased substantially in the 2016-2022 time period compared to the 2007-2011 period, reflecting the genetic gain and higher yield potential of newer hybrids (Figure 10 and 11).

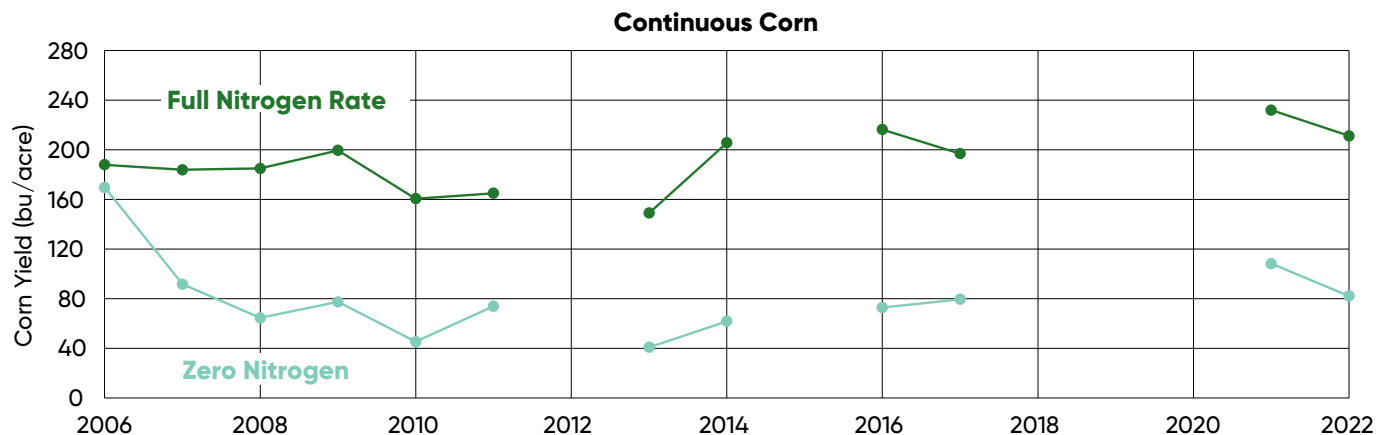
- Nitrogen treatment rates were higher for the latter time period, due to the switch to higher fixed rates beginning in 2012.
- Yield response to nitrogen rate in continuous corn was similar between time periods, with the zero nitrogen treatment yielding 60% less than the full nitrogen rate treatment in both 2007-2011 and 2016-2022.
- In rotated corn, however, nitrogen rate response changed considerably between time periods, with yield response to nitrogen nearly disappearing during the 2016-2022 period.
- The zero nitrogen treatment in rotated corn reduced yield by 37% compared to a full rate in 2007-2011, but only 4% in 2016-2022 (Figure 11).
- Visual nitrogen deficiency symptoms in the field corresponded with measured yield results.
- Distinct yellowing of the plants was observed in the lower nitrogen rates in continuous corn, with detectable deficiency symptoms in the zero nitrogen strip appearing soon after emergence.
- In the rotated corn, nitrogen deficiency symptoms were nearly nonexistent in the latter years of the study, even in the zero nitrogen strip.



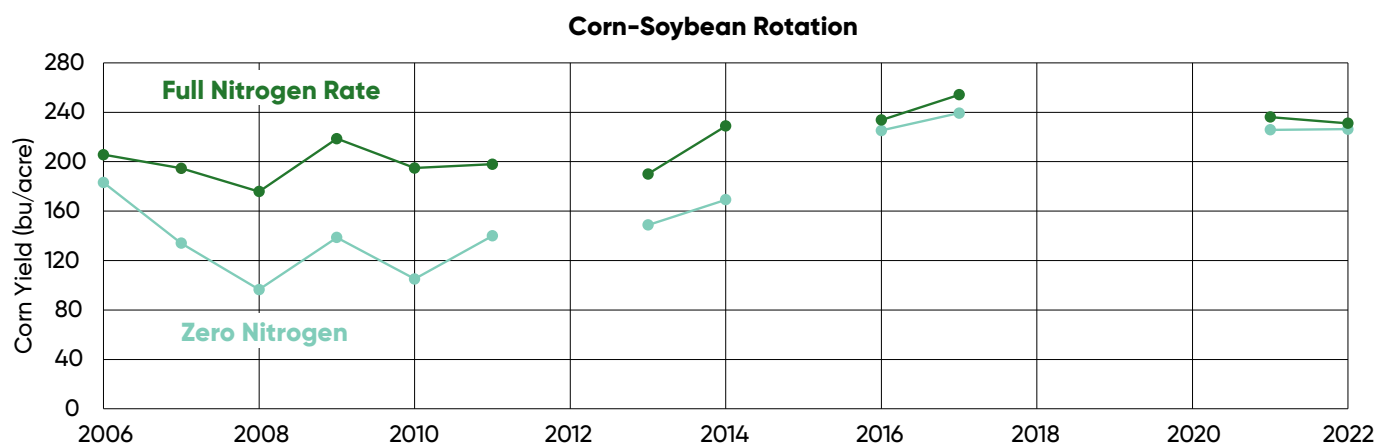
**Figure 10.** Corn yield response to nitrogen rate in continuous corn and corn-soybean rotation at Johnston, IA from 2007-2011. Actual nitrogen rates differed by years, so rates shown are averages for this time period.



**Figure 11.** Corn yield response to nitrogen rate in continuous corn and corn-soybean rotation at Johnston, IA from 2016-2022.



**Figure 12.** Yield of continuous corn with a full nitrogen rate and zero nitrogen at Johnston, IA from 2006–2022.



**Figure 13.** Yield of rotated corn with a full nitrogen rate and zero nitrogen at Johnston, IA, from 2006–2022.

- Figures 12 and 13 show corn yield of the full nitrogen rate and zero nitrogen treatments in continuous corn and rotated corn, respectively, over all years of the study at Johnston, IA.
- Relatively little yield loss occurred with zero nitrogen in the first year of the study, but yields dropped off substantially in the second and third years.
- Beyond the third year, yield loss with zero nitrogen stayed relatively constant in continuous corn with approximately 60% yield reduction compared to a full nitrogen rate.
- In rotated corn, however, yield in the zero nitrogen treatment recovered over time. The yield gap appears to narrow somewhat in 2013 and 2014 and nearly disappears in 2016.
- The years following 2016 in which it was possible to collect yield data all produced similar results, with the yield penalty not exceeding 6% in 2017, 2021, and 2022.
- Yield outcomes for the other reduced nitrogen rates are not shown but followed similar trends as the zero nitrogen treatment, gradually closing the yield gap with the full rate treatment over time.
- Caution is justified in considering the results, as this is a non-replicated trial, conducted at only one location in its later years.
- However, it is worth noting that the yield data for the corn soybean rotation came from two separate blocks. If some sort of plot effect or misapplication of fertilizer was affecting the outcome, it would most likely show up in the even-numbered or odd-numbered years, but not both.
- The long-term trends observed in this study at the Johnston site were unexpected and the reason for them is unknown. Further investigation is warranted. This study remains ongoing.

# Introduction to the Plant Microbiome

Mark Jeschke, Ph.D., Agronomy Manager

- Plants are colonized by a wide diversity of microorganisms that live both on and inside plant tissue; a community of organisms referred to as the microbiome.
- Recent advances in high-throughput genome sequencing and several other technologies have greatly expanded the ability to study complex microbiomes.
- This growing body of research on plant-microbe interactions has led to a rapid proliferation of microbial products in the crop input marketplace, all seeking to improve crop health and productivity by altering some aspect of the microbiome.
- Bacterial and fungal symbionts are the most well-known and studied, but the plant microbiome can also include archaea, protists, oomycetes, and viruses.
- Research thus far has demonstrated several beneficial effects that microbial symbionts can provide in crop plants, including nitrogen fixation, enhanced stress tolerance, and disease suppression.
- The need for sustainable solutions for existing issues in agricultural production and to drive gains in crop yield and resilience in the coming years will continue to fuel growth in microbiome research and microbial products.

*"All animals and plants form associations with microorganisms, including protists, bacteria, archaea, fungi, and viruses."*

## PLANTS CONTAIN MULTITUDES

The fact that microorganisms can play an important role in crop growth and yield should not come as a surprise to those working in crop production. Producers of leguminous crops such as alfalfa or soybeans understand that a significant portion of the nitrogen those plants need to grow comes from bacteria that colonize the roots. In return, the bacteria receive organic acids from the plants as a source of carbon and energy. The relationship between the organisms benefits both of them – a type of symbiosis referred to as mutualism.

What is likely not as well understood, is the fact that this type of interaction is not limited to legumes, it occurs in all plants and can involve numerous types of microorganisms that interact with the plant in a variety of ways. Broadly speaking, the term microbiome refers to the community of microorganisms living together within a given habitat.



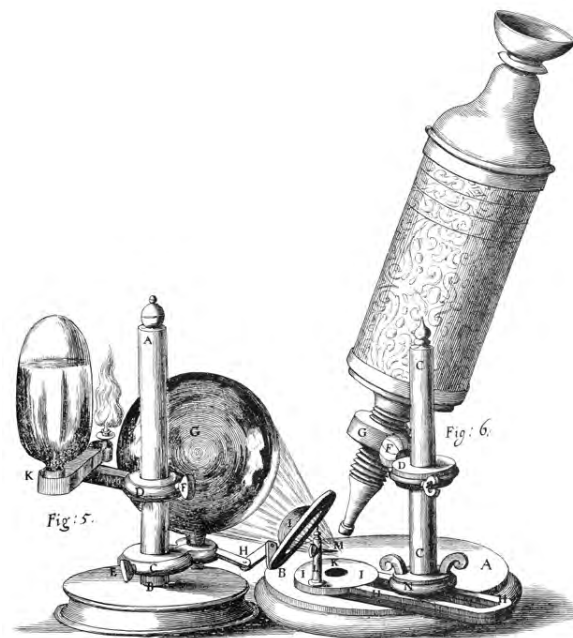
**Figure 1.** The symbiotic relationship between legume plants and *Rhizobium* bacterial species was first discovered in 1888. Since then, we have learned that it is just one of many symbiotic interactions between plants and microorganisms.

All animals and plants form associations with microorganisms, including protists, bacteria, archaea, fungi, and viruses. Plants are colonized by a wide diversity of microorganisms that live both on and inside plant tissue. These microorganisms can interact with the host plant and each other and can have significant effects on plant health and productivity. This complex community of microorganisms is referred to as the plant microbiome.

## MICROBIOME RESEARCH

### Let's Get Small

Scientific study of microorganisms began in the 17th Century with the invention of the microscope, which allowed them to be observed for the first time. Research in the 19th Century showed that microorganisms were the cause of diseases in plants. Initially, it was believed that healthy plants were free of microorganisms and that their presence was exclusively associated with disease. However, research in the 19th and early 20th centuries demonstrated the existence of beneficial microorganisms in plants. One of the most important of these early discoveries was nitrogen-fixing bacteria in the root nodules of legumes in 1888.



**Figure 2.** Robert Hooke's microscope from Scheme I. of his 1665 *Micrographia*. The invention of the microscope facilitated the first study of microorganisms in the 17th Century.

Subsequent research revealed that only a small proportion of microorganisms are associated with disease or pathogenicity. The overwhelming majority of microorganisms are essential for ecosystem functioning and can have beneficial interactions with macroorganisms as well as other microorganisms. The term *endophyte* was coined to refer to microorganisms that spend at least a portion of their lifecycle inside plants without causing any apparent harm (Hallmann et al., 1997).

### Challenges in Studying Microorganisms

Historically, understanding of plant-microbe interactions has been limited by the need to isolate and culture microbes in order to study them. Not all microbes can be cultured in a laboratory environment, so research was confined to those that can. This left numerous microbes largely uninvestigated. Furthermore, research on plant-microbe interactions commonly involved host plants grown in controlled, optimized conditions that may not reflect field conditions where environmental variables and stresses can influence microbe activity.



**Figure 3.** For a long time, the study of microorganisms was largely confined to those organisms that could be cultured in a laboratory environment.

## Rapid Growth in Microbiome Research

Recent advances in high-throughput genome sequencing and several other technologies have greatly expanded the ability to study complex microbiomes. This has led to an increased focus on how microorganisms influence plant growth and yield in crop species and opportunities to alter or enhance the microbiome to increase crop productivity and resilience against pests and abiotic stress. Areas of research that are rapidly expanding our understanding of plant microbiomes include:

- o **Metagenomics:** The collection and sequencing of a bulk sample of all genetic material extracted directly from a given environment, allowing the identification of all species present in the sample. Metagenomics offers the advantage of analyzing genomes of nonculturable microorganisms.
- o **Metatranscriptomics:** A set of techniques used to study gene expression of microorganisms. In contrast to metagenomics, which involves determining which species of microorganisms are present in an environment, metatranscriptomics is the study of which genes they are expressing, which can provide a picture of what they do and how they respond to different environments.
- o **Metabolomics:** The large-scale study of small molecules known as metabolites within cells, biofluids, tissues or organisms. Studying plant metabolites can be useful in understanding how microorganisms are affecting them.
- o **Advanced Microscopy:** Powerful imaging technologies such as confocal laser scanning microscopy have expanded the ability to directly observe microorganisms within plant tissues, providing insight on how and where microorganisms live within a plant.

The first step in understanding plant-microorganism interactions often involves characterizing the microbiome – quantifying which species (or categories of species) are present and in what quantities. Organisms whose presence correlates to crop yield can then be evaluated further to determine how they are interacting with the plant and environmental conditions that can increase or decrease their activity.

This growing body of research on plant-microbe interactions has led to a rapid proliferation of microbial products in the crop input marketplace, all seeking to improve crop health and productivity by altering some aspect of the microbiome. Navigating this marketplace of microbial products and understanding how we might influence the microbiome to increase yield requires some basic knowledge of how the plant microbiome works – the types of organisms involved, how they colonize the plant, and what they do.

## TYPES OF MICROORGANISMS

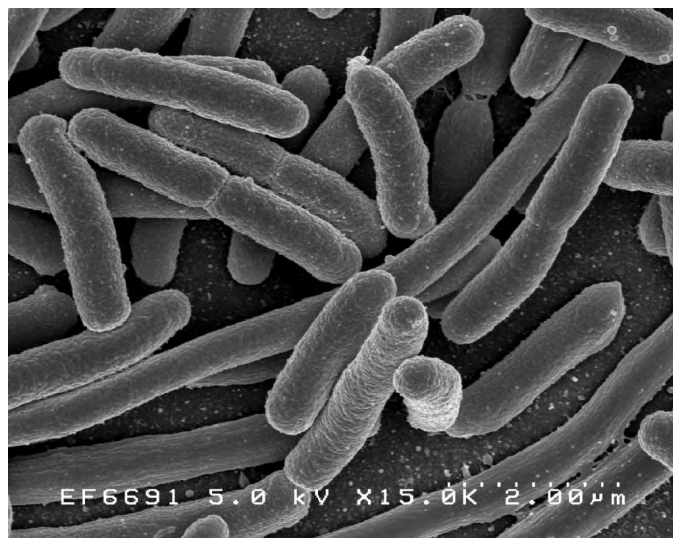
An important aspect of the plant microbiome to understand is just how vast it can be in terms of the number and diversity of organisms. A single gram of soil can contain up to a billion bacterial cells representing tens of thousands of different

species (Roesch et al., 2007), and that is just one of the types of microorganisms that can form associations with plants. Several types of microorganisms can function as symbionts of plants. Bacterial and fungal symbionts are the most well-known and studied, but the plant microbiome can also include archaea, protists, oomycetes, and viruses.

### Bacteria

Bacteria are single-celled microorganisms found nearly everywhere on Earth and are the dominant component of plant microbiomes. Bacteria are prokaryotes, meaning they lack a true nucleus and membrane-bound organelles. Their genetic material consists of a single, circular DNA molecule. Some are autotrophs, producing their own food through processes like photosynthesis, while others are heterotrophs, relying on external sources of organic carbon. Bacteria play crucial roles in nutrient cycling and decomposition. They help break down organic matter into simpler substances, making nutrients available to plants and other organisms.

Bacteria in the genus ***Rhizobium*** are the most well-known bacterial symbiont of plants. The bacteria colonize the root cells of certain plant species to form nodules where they convert atmospheric nitrogen gas into ammonia that the plants can use for their growth. In turn, the host plants provide the bacteria with carbohydrates in the form of sugars and other organic compounds through photosynthesis.



**Figure 4.** Bacteria are the largest and most well-studied component of plant microbiomes.

### Fungi

Fungi are a diverse group of eukaryotic organisms. Fungi are heterotrophs, which means they cannot produce their own food through photosynthesis. Instead, they obtain nutrients by absorbing organic matter from their surroundings. Fungi have significant ecological importance. They form symbiotic relationships with plants (mycorrhizae) and help plants absorb water and nutrients from the soil. Fungi are also important decomposers, breaking down organic matter and recycling nutrients in ecosystems. The morphology of fungi can be highly variable, allowing them to inhabit diverse environments.

Mycorrhizal fungi are one of the most well-known fungal symbionts of plants. Plants provide mycorrhizal fungi with carbohydrates produced through photosynthesis that serve as a source of energy for the fungi. Mycorrhizal fungi, with their extensive hyphal networks, extend the effective surface area of plant roots, enabling better absorption of water and nutrients—especially phosphorus and nitrogen—from the soil.

### Protists

Protists are eukaryotic microorganisms, which means their cells have a true nucleus and membrane-bound organelles. Some are unicellular while others are multicellular. Protists can be found in various habitats, including freshwater, marine environments, soil, and the bodies of other organisms. Some protists, like algae, are photosynthetic and play a vital role in aquatic ecosystems by producing oxygen and serving as the base of the food chain.

Protists can influence host plants directly, as well as indirectly through their interactions with bacteria and fungi (Nguyen et al., 2023). Known beneficial functions of protists associated with crop species include effects on biomass allocation and nitrogen translocation in the root system of wheat by *Acanthamoeba castellanii* (Henkes et al., 2018) and suppression of *Fusarium* rot in faba bean by *Rosculus terrestris* (Bahroun et al., 2021).

### Archaea

Archaea are a distinct group of single-celled microorganisms that, like bacteria, are prokaryotes. However, differences in cell wall composition, membrane structure, and genetic processes highlight their distinct evolutionary paths and separate them into two distinct domains of life. Archaea was first recognized as a separate domain of life in the late 1970s, largely based on the work of microbiologist Carl Woese at the University of Illinois. Archaea share similarities with both bacteria and eukaryotes (organisms with complex cells). Archaea are known for their ability to thrive in extreme environments, such as hot springs, acidic environments, and deep-sea hydrothermal vents.

Haloarchaea are a class of archaea that can tolerate extremely high salt concentrations. Some genera of haloarchaea can solubilize phosphorus. Recent research suggests archaea colonizing the rhizosphere of plants in hypersaline soils may play a role in phosphorus nutrition, helping the plants to survive in extreme saline environments (Yadav et al., 2015).

### Oomycetes

Although often referred to as "water molds," oomycetes are not fungi but belong to a distinct lineage of fungus-like microorganisms. This classification includes some well-known plant pathogens, such as *Pythium* and *Phytophthora* species.

Although the majority of known oomycete species are plant pathogens, some can form mutualistic relationships with certain plant species. These associations involve oomycetes and plants working together in a way that mirrors the mutualistic relationships between plants and fungi.

### Viruses

Viruses straddle the line between living and non-living things. Viruses are not made up of cells; they consist of genetic material (either DNA or RNA) surrounded by a protein coat called a capsid. Viruses lack the cellular machinery necessary for metabolism and energy production. They cannot carry out essential life processes on their own and must rely on host cells to replicate and reproduce. Viruses are usually highly specific to the type of host organism and even specific cell types within that organism.

Viruses have long been associated with disease; however, recent advances in next-generation sequencing have begun to reveal the mutualistic relationships that exist between plants and viruses (Fadji et al., 2022, Roossinck, 2015a). Endophytic viruses have been shown to increase tolerance of plants to abiotic stress in some instances (Roossinck, 2015b).

## WHERE MICROORGANISMS LIVE

Microorganisms live both on the external surface of a plant and inside the plant and can colonize both above- and below-ground tissues. The term **endophyte** refers to a microorganism that colonizes internal plant tissues for at least a portion of its lifecycle. The **endosphere** consists of all microorganisms that live inside the plant (endophytes), including above- and below-ground plant tissues. **Epiphytes** are microorganisms that adhere to external plant surfaces such as roots, shoots, leaves, and flowers.

The **rhizosphere** is the volume of soil directly surrounding a plant's roots where the microbiome is directly influenced by root exudates. The rhizosphere can contain many types of bacteria, fungi, and other microorganisms that feed off dead root cells or proteins and sugars exuded by the roots. The **rhizoplane** refers to the interface where the root tissue and soil particles contact and interact with each other. **Bulk soil** refers to soil that is not influenced by plant roots (i.e., everything that is not part of the rhizosphere).

The **phyllosphere** consists of the total aboveground surface of a plant – including stems, leaves, flowers, and fruits – that can serve as a habitat for microorganisms. Compared to the rhizosphere, the phyllosphere is a much more dynamic and harsher environment, subject to ultraviolet radiation, rainfall, and diurnal variations in temperature. Consequently, the phyllosphere microbiome is generally less abundant and diverse than that of the rhizosphere.

## THINGS THAT MICRO-ORGANISMS DO

A close biological interaction between two dissimilar species is referred to as symbiosis. The term symbiosis is often used to refer to relationships that are mutually beneficial, but this is only one of the three main types of symbiotic relationships:

○ | "A close biological interaction between two dissimilar species is referred to as symbiosis."

**Mutualism** refers to a relationship in which both species benefit from the interaction.

**Commensalism** is a relationship that benefits one species while the other is neither helped nor harmed.

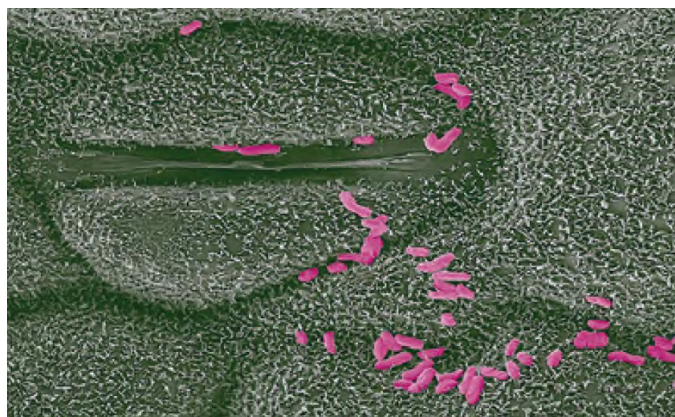
**Parasitism** is a relationship in which one species benefits at the expense of the other. The parasite benefits by deriving nutrients from the host, which is harmed in the process.

In the context of crop management systems and, specifically, examining how the microbiome might be utilized to increase crop productivity, interest is primarily focused on mutualistic relationships – microorganisms associated with crop species that provide a benefit to the host plant.

Research thus far has demonstrated several beneficial effects that microbial symbionts can provide in crop plants:

### Nitrogen Fixation

The most well-known function of microbial symbionts of plants is nitrogen fixation. This is carried out by species of bacteria and archaea with nitrogenase enzymes – known as diazotrophs – that are able to fix gaseous nitrogen in the atmosphere into forms usable to plants. Diazotrophs can colonize and associate with plants in a variety of ways. *Rhizobium* species colonize the root nodules of legumes. *Azospirillum* species are free-living soil bacteria that associate with the roots of various plants, including grasses and cereals (Gomez-Godinez et al., 2018). *Methylobacterium symbioticum* colonizes corn plants through the leaves where it scavenges methanol produced by the plant as a food source (Pascual et al., 2020; Vera et al., 2023).



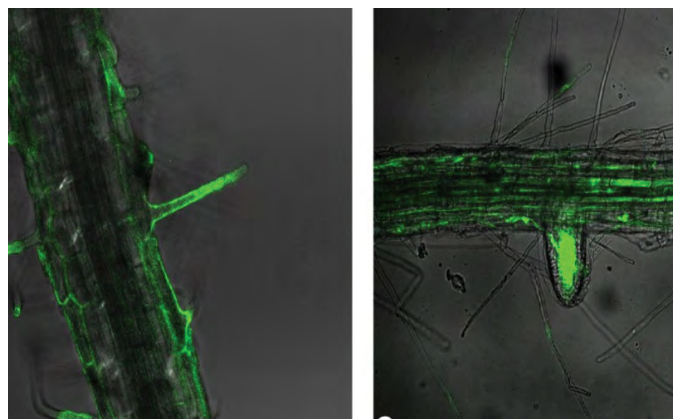
**Figure 5.** *Methylobacterium symbioticum*, the active ingredient in Utrisha® N on the surface of a plant leaf. *M. symbioticum* enter the plant through the stomata and rapidly colonize the entire plant.

### Abiotic Stress Tolerance

Two strains of bacteria (*Pseudoduganella* and *Bosea* species) that colonize the roots of corn plants have been shown to boost corn growth under chilling conditions (Beirinckx et al., 2020). Arbuscular mycorrhizal fungi can improve corn tolerance to drought stress by regulating aquaporins (membrane proteins that serve as channels in the transfer of water) in corn (Quiroga et al., 2017).

### Improved Plant Health and Function

Several genera of bacteria have shown the ability to promote growth in corn through the production of plant growth hormones (Arshad and Frankenberger, 1991; Shi et al., 2017).



**Figure 6.** Roots colonized by *Bacillus amyloliquefaciens* (shown by green fluorescence), the active ingredient in Utrisha® P.

### Nutrient Uptake and Availability

Microorganisms can increase phosphorus uptake in plants by facilitating the transport to the roots via mycorrhizal fungi (Smith and Read, 2008) or by solubilization or mineralization of phosphorus-containing molecules (Mander et al., 2012).

The active ingredient in Utrisha® P, *Bacillus amyloliquefaciens* strain FZB45, colonizes plant roots (Figure 6) and increases phosphorus availability by producing phosphatase enzymes and organic acids that solubilize organic phosphorus molecules into plant-available forms and producing siderophores that degrade iron-phosphate compounds by chelating iron.

### Disease Suppression

Some bacterial and fungal species are associated with enhanced disease resistance in plants. *Methylobacteria* have been shown to induce disease resistance via production of antimicrobial compounds and have positively correlated with disease resistance in corn (Wallace et al., 2018). *Trichoderma harzianum* is a fungal species that interacts with plants roots and has been shown to trigger induced systemic resistance to foliar disease in corn (Saravanakumar et al., 2016).

## CHALLENGES AND FUTURE POTENTIAL

Recent advances in technical and computational tools have facilitated a rapid expansion in research on the microbiomes of crop species. In the production agriculture sphere, this growth in research has led to a proliferation of biostimulants, biopesticides, and other biological products that offer the potential to improve crop health and yield by influencing the composition of the crop microbiome.

## BIOLOGICALS VS. MICROBIALS

In the agricultural marketplace, the terms *biological* and *microbial* are sometimes used interchangeably to refer to any non-synthetic crop input product; however, they are not the same thing.

The term **biologicals** in agriculture encompasses a diverse and rapidly growing array of non-synthetic crop production inputs. Generally, these are crop treatments comprised of living organisms or substances derived from living organisms. Examples of biologicals include beneficial insects, microorganisms, and plant extracts. Biologicals can benefit a crop directly through their interactions with the crop plant or indirectly through their effect on other organisms that can impact the crop such as insects or nematodes.



**Microbials** are a subcategory of biologicals comprised of living microorganisms such as fungi, bacteria, protozoa, and viruses. As with the broader category of biologicals, microbials may interact with the crop plant directly or via their effect on another species. Microbials that affect the plant directly by colonizing on or within plant tissues function as a part of the plant's microbiome.

### Current Biological Products

- o The active ingredients in **Urisha® N** (*Methylobacterium symbioticum*) and **Utrisha P** (*Bacillus amyloliquefaciens*) are both **microbials** – living organisms that form mutualistic associations with crop plants and function as part of the microbiome. *M. symbioticum* colonizes internal plant tissues through the leaves and fixes nitrogen inside the plant. *B. amyloliquefaciens* colonizes plant roots and solubilizes organic phosphorus molecules into plant-available organic forms.
- o The active ingredient in **Sosdia® Stress** abiotic stress mitigator (proline) is considered a **biological** but not a microbial. It is a natural organic molecule that is applied to crop plants, but it is not a living organism.
- o The active ingredient in **Hearken™** biological insecticide is a virus that infects *Helicoverpa* insect species. Since it's a virus, it's considered a **microbial**, but it works by directly infecting the target species – it does not form a symbiotic relationship with the host plant or function as part of its microbiome.



Microbiomes are vast and complex networks of life, and much remains to be learned about how microorganisms can be leveraged to improve crop productivity and resilience. In corn, there are large disparities in the quantity of research that has been done on different components of the microbiome. The corn rhizosphere (belowground) has been researched to a much greater extent than the phyllosphere (aboveground). Bacterial communities have been researched far more than fungal communities, and both have been researched more than other types of microorganisms (Singh and Goodwin, 2022).

o | "Much remains to be learned about how microorganisms can be leveraged to improve crop productivity and resilience."

Inconsistencies among microbiome studies has been a major issue. Differences in results may be driven by discrepancies in study designs and methods but may also be driven by environmental differences

(Singh and Goodwin, 2022). Likewise, results of agricultural field studies with biostimulant products have also often been inconsistent. One likely reason for this is the fact that any microorganism applied to a crop plant is entering an environment where it must interact and compete with billions of other microorganisms that are already there and may be better adapted to the environment (Peltier et al., 2023).

Numerous environmental and management factors can influence the composition of the crop microbiome, so the microbial community that a microbial product encounters can vary from field to field. Adding to that variability is the fact that the unique set of environmental conditions in a field in a given year can have a large impact on whether a biological product produces a measurable effect. A nitrogen-fixing bacteria, for example, may function exactly as intended but not produce a significant yield gain if plant-available nitrogen is already abundant in a field.

Despite these challenges, tremendous opportunities exist for using the crop microbiome to increase crop health and productivity. Research in this area will continue to expand and will undoubtedly help overcome obstacles and open up new opportunities. The need for sustainable solutions for existing issues in agricultural production and to drive gains in crop yield and resilience in the coming years will continue to fuel growth in this area.





# Is Smoke from Wildfires Affecting Crop Yields?

*Mark Jeschke, Ph.D., Agronomy Manager*

- In the Corn Belt region, noticeable levels of smoke in the air during summer and fall have become commonplace over the past several years.
- Wildfires in the Western U.S. and Canada have gotten worse in recent years and will almost certainly continue to increase in frequency and intensity.
- The greatest potential impact of wildfire smoke on crop growth and yield comes through the reduction in sunlight that reaches the crop.
- Wildfire smoke contains multiple pollutants that can be harmful to crops, but it's not clear that smoke increases the ground-level concentration of these compounds enough to have an impact.
- There are multiple mechanisms through which wildfire smoke could cause reductions in crop yields, but it's unlikely that the smoky conditions experienced over the past few years have had a measurable impact in most areas.
- The effects of wildfire smoke on both agricultural and natural ecosystems are likely to be an active area of research in coming years, as smoky days become more common.

## WILDFIRE SMOKE BECOMING MORE COMMON

The past several years have been marked by an increase in the frequency and severity of wildfires in the Western U.S. and Canada. The effects of these fires have been devastating on the areas directly impacted, and smoke from the fires has been a frequent health concern in nearby population centers. It has also become increasingly apparent that the impact of these wildfires can extend far beyond the immediate area. Wildfire smoke can and does impact air quality throughout North America.

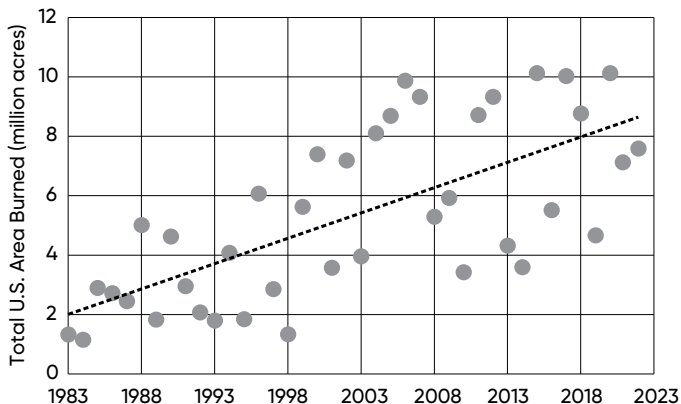
In the Corn Belt region, noticeable levels of smoke in the air during summer and fall have now become commonplace. Wildfire smoke is often most noticeable in the evenings, with hazy red sunsets resulting from the filtering of sunlight through the particulate matter suspended in the atmosphere. During the day, the smoke creates a persistent cloudy haze in the air, reducing the intensity of direct sunlight and making it more diffuse.

The increased frequency of smoky days in agricultural areas raises the question of what impact the smoke might be having on crop productivity. Ample sunlight is critical for maximizing plant photosynthesis and crop yield, and lower than normal solar radiation during grain fill can be detrimental. Corn, in particular, is susceptible to reduced yields and reduced standability if the plants need to remobilize carbohydrates from the stalk to make up for a deficit in photosynthesis. This weakens the stalks and opens the door for stalk rot pathogens.

## WHY ARE WILDFIRES GETTING WORSE?

Wildfires in North America have gotten considerably worse in recent years. Over the past 40 years, the total burned area from wildfires in the U.S. has approximately quadrupled, from around 2 million acres annually to over 8 million acres (Figure 1). In Canada, 2023 was worst wildfire season in recorded history by a wide margin, with over 38 million acres burned. This was more than double the total area burned of any previous year (CIFFC, 2023).

The increase in fire risk in North America has been driven by two major factors: increased fuel load in forested areas resulting from decades of fire management practices focused on fire suppression, and increased fuel aridity due to a hotter and drier climate.



**Figure 1.** Total acres burned by wildland fires in the U.S., 1983–2022. Source: NIFC Wildland Fire Statistics, 2023.



**Figure 2.** Smoke from Canadian wildfires over the Corteva Agriscience research farm at Johnston, Iowa. June 28, 2023.

### Forest Management

Fire is a natural feature of many forest ecosystems and controlled burns were common practice across the landscape for generations. In the early 20th Century though, focus started to shift away from forest management in favor of fire suppression after a devastating fire in 1910 known as the “Big Burn” consumed over 3 million acres across Washington, Idaho, and Montana and killed at least 85 people. This event had a long-term impact on the policy direction of the U.S. Forest Service, which had been founded five years prior (Tidwell, 2010).

“The increase in fire activity over the past 20 years has largely been driven by climate change.”

The outcome of decades of policy focused on fire suppression has been a buildup of fuel in many forested areas. Even though the importance of prescribed burning for fire risk mitigation is now well-understood, doing it has become more difficult due to the expansion of residential development in the wildland urban interface and the diversion of limited fire management resources into protecting homes and businesses from increasingly frequent and intense wildfires. A massive increase in tree mortality following an extended period of drought in California has further increased the supply of combustible fuel (Stephens et al., 2018), dramatically increasing the near-term risk of devastating fires in affected areas.

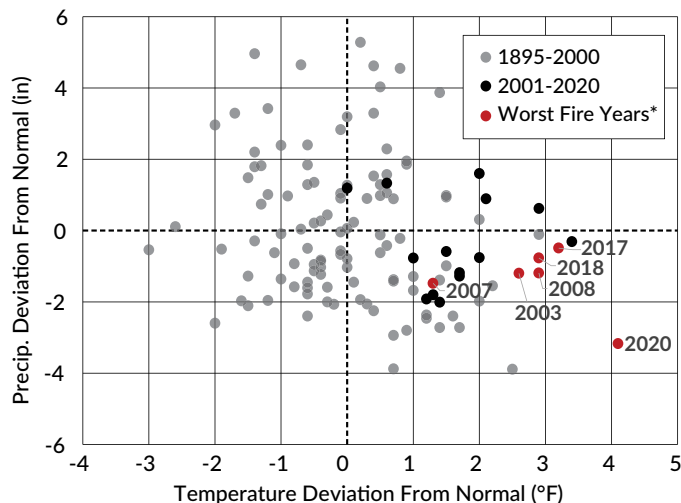
The outcome of decades of policy focused on fire suppression has been a buildup of fuel in many forested areas. Even though the importance of prescribed burning for fire risk mitigation is now well-understood, doing it has become more difficult due to the expansion of residential development in the wildland urban interface and the diversion of limited fire management resources into protecting homes and businesses from increasingly frequent and intense wildfires. A massive increase in tree mortality following an extended period of drought in California has further increased the supply of combustible fuel (Stephens et al., 2018), dramatically increasing the near-term risk of devastating fires in affected areas.

### Climate Change

The risk posed by increased fuel loads in western forests has been exacerbated by climate change, which has manifested through increased temperatures and lower precipitation during the fire season, a lengthening of the fire season due to higher spring and fall temperatures, earlier snowmelt, and reduced river flows. All of these factors have contributed to make fuel loads in forests drier and more combustible (Overpeck and Udall, 2020).

The increase in fire activity over the past 20 years has largely been driven by climate change, with hotter, drier conditions leading to larger and more frequent fires (Abatzoglou and Kolden 2013). The six worst wildfire years in California – years

in which over 1 million acres burned – have all been years with above-average temperatures and below-average precipitation during the July to November fire season (Figure 3). This set of conditions is occurring with increasing frequency. Average fire season temperatures have exceeded the 20th Century average every year since 2004, with the 2020 season setting a new high of over 4° F above average as well as a new record of over 3 million acres burned.



**Figure 3.** California temperature and precipitation deviation from average from July–November of each year, 1895–2020. \*Over 1 million acres burned. Source: NOAA National Centers for Environmental Information

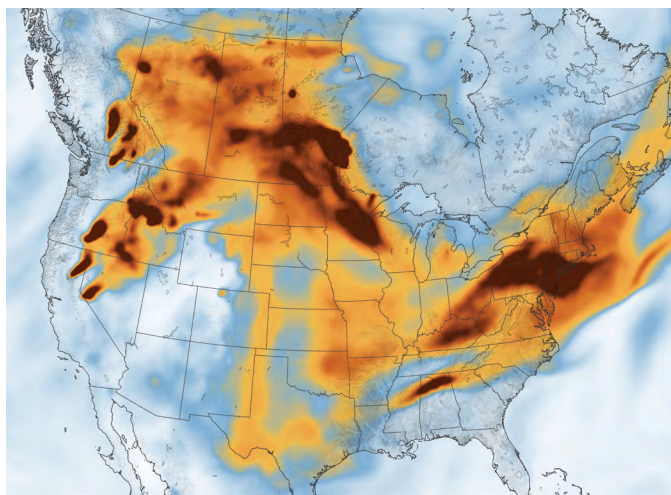
In the aftermath of wildfires – particularly those occurring near populated areas – attention is often focused on the source of ignition, under the implicit assumption that reducing or eliminating sources of ignition would be an effective means of reducing the problem of wildfires. Preventing human-caused wildfires is certainly important – entire decades-long public service campaigns have been built on this premise (Smokey Bear et al., 1944). However, the major source of ignition for wildfires is, and always has been, lightning strikes (Pérez-Invernón et al., 2023). Sources of ignition will always exist; what matters is the environmental conditions that determine whether the fire smolders and burns out or explodes into a major conflagration (Figure 4).



**Figure 4.** Smoke from wildfires in Quebec, June 3, 2023. Lightning strikes from a storm system can ignite multiple fires in an area that will then all flare up at the same time when conditions turn hot and dry. Source: NASA Earth Observatory

## IMPACT OF WILDFIRE SMOKE

The increase in wildfire activity has led to a substantial increase in the number of days each year impacted by smoke in the air. Effects of wildfire smoke extend far beyond the immediate vicinity of the fires, with increases observed throughout the U.S. (Burke et al., 2021). The heat generated by active fires lifts smoke high into the atmosphere. At high altitudes, the smoke can travel with jet stream winds across the continent (NASA, 2017). Pockets of concentrated smoke can sometimes occur far from the fires that generated it (Figure 5). Smoke is most noticeable and poses the greatest human health threat when it descends to the surface; however, smoke at any altitude has the potential to affect crop growth by reflecting and scattering incoming sunlight.



**Figure 5.** Smoke concentration in the atmosphere over North America from fires in the Western U.S. and Canada, July 21, 2021. Source: NASA Earth Observatory.

Given what is known about the factors that have led to increased wildfire activity, it’s a virtual certainty that wildfire smoke in the atmosphere will continue to increase in frequency and concentration for the foreseeable future, making it important to understand how crop growth and productivity might be affected.

## EFFECTS ON SUNLIGHT

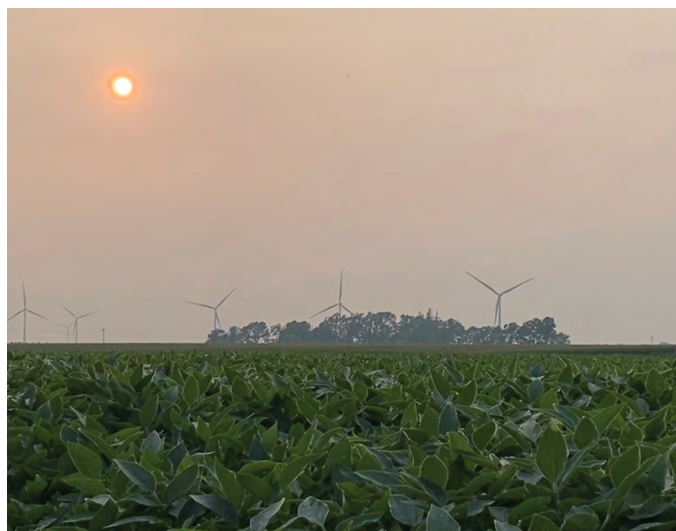
The greatest potential impact of wildfire smoke on crop growth comes through the effects that it can have on sunlight that reaches the crop; specifically, its ability to reduce sunlight intensity and increase sunlight diffusion (Figure 6).

### Reduced Sunlight Intensity

The most obvious effect of wildfire smoke in the atmosphere is a reduction in total solar radiation. Much like a hazy cloud cover, smoke reflects a portion of incoming sunlight, reducing the amount of light available to plants. Since plants depend on sunlight to carry out photosynthesis, any reduction in light is potentially detrimental to crop productivity. Plants with the C4 carbon fixation pathway, such as corn, have a higher light saturation point, making them more susceptible to reductions in solar radiation than C3 plants such as soybeans.

### Increased Diffusion of Sunlight

In addition to reflecting a portion of incoming light, smoke also scatters it, making the light available to plants more diffuse. Wildfire smoke can significantly increase the diffuse fraction of photosynthetically active radiation (PAR), which can benefit plants by increasing their light use efficiency. The potential effect of more diffuse light on plant growth depends on the characteristics of the plant canopy, with taller, higher leaf area index, and multilayer canopies likely to benefit more from diffuse radiation than shorter plants.



**Figure 6.** Smoky sunset in central Iowa. July 31, 2021.

### Complex and Interacting Effects

Of the two primary effects of wildfire smoke on photosynthetically active radiation, one of them – reduced total solar radiation – is likely to be negative in most circumstances, while increased diffusion of solar radiation could potentially be positive for crop growth. The ultimate effect on crop growth and yield will depend on the relative impact of these factors. For example, any benefit derived from increased diffuse radiation could be negated if the reduction in total solar radiation is too great.

Additional effects could come into play as well. Reduction in solar radiation can reduce surface temperatures, which may be good, bad, or neutral depending on the timing and circumstances. If a crop is suffering through a period of drought stress, a temporary moderation of daytime temperatures may be helpful. On the other hand, if a crop is running behind in its development due to below-normal GDU accumulation, further reductions in temperature from wildfire smoke will likely make things worse.

## SOLAR RADIATION AND CROP PRODUCTION

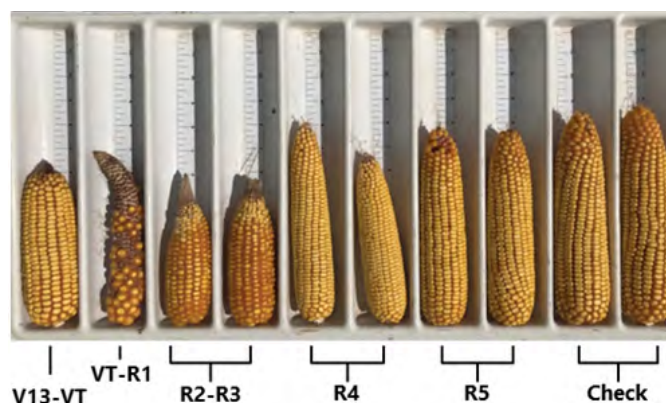
Numerous experiments over the years have studied the impact of reduced solar radiation on corn yields using shade cloths that cover a portion of the crop canopy and reduce the intensity of incident solar radiation by a certain amount. These studies have provided some important insights on the effects of reduced solar radiation on corn.

**Table 1.** Percent corn yield reduction associated with three different levels of shading (15%, 30%, and 50%) for two hybrids at three different plant densities (Yang et al., 2019).

Density (plants/acre)	Hybrid 1			Hybrid 2		
	15%	30%	50%	15%	30%	50%
	————— yield reduction (%) —————					
30,400	NS*	NS	35	13	19	50
42,500	NS	19	42	15	25	55
48,500	NS	24	51	14	29	64

\* Not significant at  $\alpha=0.05$

Reductions in yield can be dramatic. Studies that have included shade treatments that reduce light by 50% or more during grain fill have seen corn yield drop by more than half (Table 1) (Yang et al., 2019).



**Figure 7.** Effects of a 70% shade treatment applied at different timings on corn pollination and ear length in a 2021 Pioneer Agronomy study (Emmert, 2021).

Timing and intensity matter. Studies that have included multiple degrees of shading have found, not surprisingly, that the more solar radiation is reduced, the greater the effect on yield. Yang et al. (2019) found that impact on yield more than doubled when shading was increased from 30% to 50% (Table 1). The timing of shading is also of critical importance in corn (Figure 7). Reductions in solar radiation during silking and grain fill have a much greater impact than the same level of reduction prior to silking (Table 2) (Liu and Tollenaar, 2009; Reed et al., 1988).

**Table 2.** Effect of shade treatment timing on corn yield (Liu and Tollenaar, 2009).

Shade Period <sup>a</sup>	Yield Reduction (%)
4 weeks pre-silking <sup>a</sup>	3.2% NS
3 weeks at silking <sup>b</sup>	12.6% **
3 weeks post-silking <sup>c</sup>	21.4% **

<sup>a</sup>Weeks relative to silking: <sup>a</sup>-5 to -1, <sup>b</sup>-1 to +2, <sup>c</sup>+2 to +5. Shading treatments reduced solar radiation by 55%

NS=not significant, \*\*= highly significant, ( $\alpha=0.05$ )

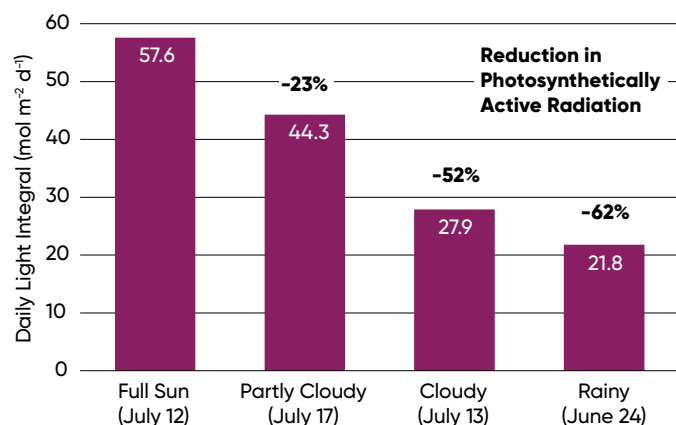
Effects can vary by hybrid and plant density. Yang et al. (2019) compared effects of shading during grain fill on two different hybrids at three different plant densities. When solar radiation was only reduced by 15%, yield impacts were similar across plant densities. As the degree of shading was increased, however, yield reductions were greater at higher plant densities. The two hybrids compared in the study also differed in their response to reduced light levels, with one hybrid consistently affected more than the other. At the 15% level of shading, yield of the more sensitive hybrid was reduced by 13–15% while the more tolerant hybrid did not have a significant reduction in yield (Table 1).

Reduced solar radiation can also affect stalk quality. In addition to direct effects on corn yield, reduced solar radiation can reduce harvestable yield by negatively affecting stalk quality and standability. Upon successful pollination, ear development places a great demand on the plant for carbohydrates. When the demands of the developing kernels exceed the supply produced by the leaves, stalk and root storage reserves are utilized. Environmental stresses which decrease the amount of photosynthate produced by the plant can force plants to extract even greater percentages of stalk carbohydrates, which preserves grain fill rates at the expense of stalk quality. As carbohydrates stored in the roots and stalk are mobilized to the ear, these structures begin to decline and soon lose their resistance to soil-borne pathogens. Instances of severe stalk rots and lodging have often been observed in association with prolonged periods of low solar radiation during grain fill.

○ *"Much like a hazy cloud cover, smoke reflects a portion of incoming sunlight, reducing the amount of light available to plants."*

### How Much Does Wildfire Smoke Reduce Solar Radiation?

Shading studies in corn have often involved treatments that reduced solar radiation by large percentages, similar to reductions that would be caused by moderate to heavy cloud cover. Data collected in Johnston, IA, found that solar radiation reductions from cloud cover ranged from 23% to 62% (Figure 8). So how much does wildfire smoke reduce solar radiation?



**Figure 8.** Daily PAR received in Johnston, IA under sunny, cloudy, and rainy conditions on four different days during summer of 2015.

**Table 3.** Daily average photosynthetic photon flux density in Wood County, Ohio (Lindsey et al., 2021).

Year	June	July
	– $\mu\text{mol}/\text{m}^2/\text{s}$ –	
2021	679	694
2017 to 2020	730	738
Difference	-7%	-6%

## DIRECT EFFECTS OF SMOKE

The Canadian wildfires of 2023 brought increased attention to the direct impacts of ground-level smoke on living organisms (Londo et al., 2023). The locations of the fires, combined with weather conditions at the time, resulted in numerous major cities in the Eastern and Midwestern U.S. being blanketed with a heavy cover of ground-level smoke for several days. This raised questions about the impacts of smoke on human health, as well as the health of living things more broadly.

### What is in Wildfire Smoke?

Smoke produced from the burning of natural biomass is composed of a complex mixture of gases and particulate matter, which includes both solids and liquids. The largest component of smoke is water vapor. Other constituents include carbon dioxide, carbon monoxide, and nitrogen oxides; however, thousands of different chemical compounds can be contained in small amounts within the particulate and gaseous fractions of wildfire smoke.

Fine particulate matter (PM<sub>2.5</sub>) is the main cause of the visible haze of smoke that reflects and scatters sunlight and is also the main concern with regards to human health. The U.S. EPA categorizes airborne particulate matter based on size:

- PM<sub>10</sub> = particles 10 micrometers or smaller
- PM<sub>2.5</sub> = particles 2.5 micrometers or smaller

For comparison, a human hair is typically 50–70 micrometers in diameter. Particles under 2.5 micrometers are the most dangerous for human health because they are small enough to penetrate deep into the lungs and enter the bloodstream. Over 90% of the particle mass in wildfire smoke is comprised of PM<sub>2.5</sub>.

### Smoke Changes Over Time

Compounds contained in wildfire smoke can undergo reactions in the atmosphere, changing the composition of the smoke over time and potentially making it more toxic (Gray, 2020). Hazardous air pollutants (HAPs) such as benzene and formaldehyde can be produced by these reactions. One of the most important of these secondary products is ozone.

### Ozone

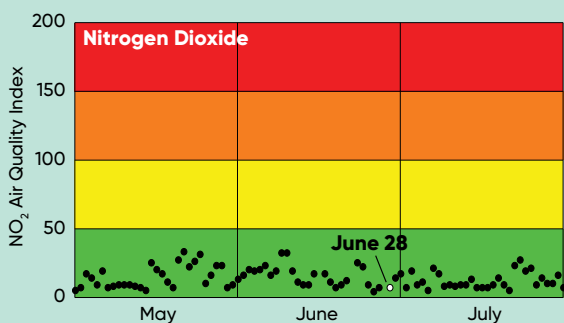
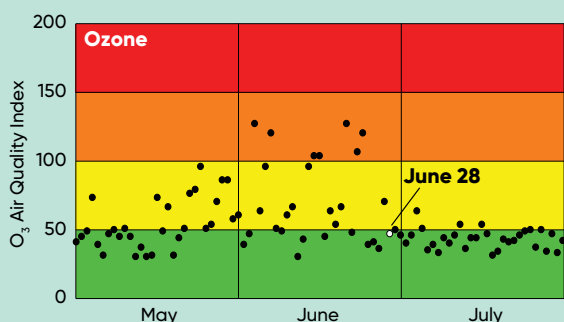
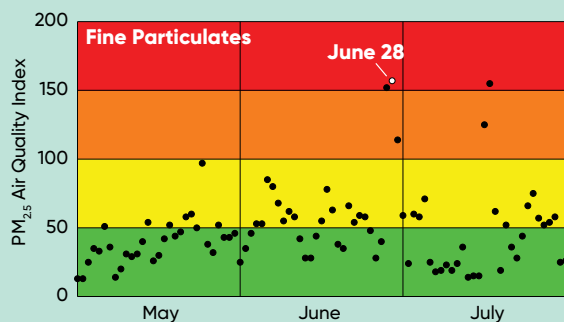
Ozone (O<sub>3</sub>) is most commonly known for the naturally occurring ozone layer in the upper atmosphere that shields Earth from harmful ultraviolet radiation. Ground-level ozone, however, is a damaging air pollutant that is harmful both to human health and plant growth.

## HOW DOES SMOKE AFFECT GROUND LEVEL AIR QUALITY?

- The air quality index (AQI) is the EPA's index for reporting air quality. Pollutant levels are indexed on a scale ranging from 0 to 500 based on their impact on human health.
- The smokiest day of 2023 at the Corteva Agriscience research farm at Johnston, IA, was June 28 (shown in Figure 1 and 9).
- The main pollutant associated with wildfire smoke is fine particulate matter (PM<sub>2.5</sub>). Air quality monitoring showed a large spike in PM<sub>2.5</sub> on June 27 and 28.
- Ground level ozone exceeded an AQI of 100 several times in June, with concentrations well into the range known to reduce crop yields, but there was no spike corresponding with the wildfire smoke, indicating that other factors were primarily driving ozone levels.
- Nitrogen dioxide levels never exceeded an AQI of 50.

### Air Quality Index (0-500 Scale)

0-50	Good
51-100	Moderate
101-150	Unhealthy for Sensitive Groups
151-200	Unhealthy
201-300	Very Unhealthy
301 and up	Hazardous



Ozone is formed when pollutants, mainly nitrogen oxides and volatile organic compounds, react in the atmosphere in the presence of sunlight. Wildfires emit large quantities of these precursor compounds. Nitrogen oxides and organic carbons produced by wildfires can be transported long distances by regional weather patterns before they react to create ozone in the atmosphere, where it can persist for several weeks.

Ground-level ozone is very harmful to plants, causing more damage to plants than all other air pollutants combined (USDA ARS, 2016). Ozone is a strong oxidant and damages plants by entering stomata and oxidizing (burning) plant tissue during respiration. Elevated ozone levels have the potential to significantly reduce crop yields. Dicot species such as soybean are generally thought to be more susceptible to yield reduction than monocot species such as corn (Heagle, 1989), although research has shown that corn and soybean are both susceptible to yield loss from ozone pollution (McGrath et al., 2015).



### Phytotoxic Effects of Pollutants

Particulate matter, ozone, nitrogen dioxide (NO<sub>2</sub>), and sulfur dioxide (SO<sub>2</sub>) are all components of wildfire smoke that are known to be harmful to plants. Furthermore, all four have been shown to reduce yields in corn and soybeans. A 2021 study estimated that the presence of these pollutants in the atmosphere has reduced yields of corn and soybean in the U.S. by roughly 5% over the past 20 years (Lobell and Burney, 2021).

However, these pollutants can come from a variety of sources other than wildfire smoke, such as industrial and automotive pollution, so the question then becomes whether the additional contribution from wildfire smoke is large enough to impact yield. Based on the available evidence, it seems unlikely. Although these pollutants are proven to reduce crop yield, exposure from sources such as industrial and automotive pollution would be relatively constant over time for crops in affected areas, whereas any additional contribution from wildfire smoke is likely to be short-lived. Furthermore, smoke plumes higher up in the atmosphere may not affect ground-level air quality at all.



# Impacts of the El Niño Southern Oscillation on Crop Production

Mark Jeschke, Ph.D., Agronomy Manager

- The El Niño Southern Oscillation (ENSO) is a natural cycle involving interactions between the ocean and the atmosphere in the tropical Pacific Ocean that affects atmospheric circulation and weather patterns globally.
- El Niño is the most well-known of the three phases of the El Niño Southern Oscillation, which also includes its opposite phase, La Niña, and a neutral phase.
- El Niño and La Niña events typically reach their peak strength during the late fall or early winter months in the tropical Pacific Ocean.
- El Niño and La Niña have their strongest influence on U.S. seasonal climate during winter, in the months shortly following the peak. Effects during summer are mostly weak or insignificant.
- Weather during the winter and early spring can have important effects on conditions going into the start of the summer growing season; however, ENSO phase is not strongly predictive of U.S. corn and soybean yields.

*"The impacts of ENSO can be significant and can have widespread effects on ecosystems, agriculture, and human activities."*



## EL NIÑO SOUTHERN OSCILLATION

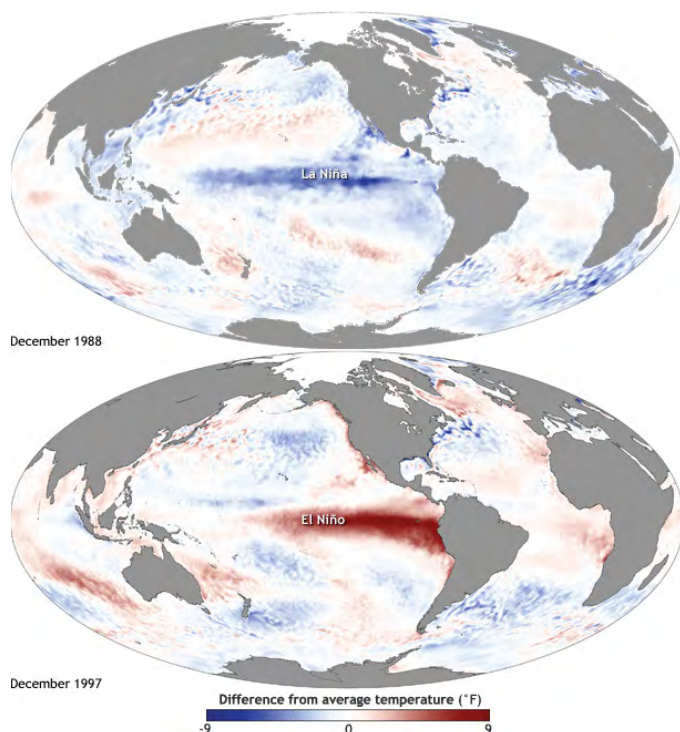
The El Niño Southern Oscillation (ENSO) is a natural phenomenon that involves the interaction between the ocean and the atmosphere in the tropical Pacific Ocean. ENSO is characterized by irregular fluctuations in sea surface temperatures, atmospheric pressure, and winds in the equatorial Pacific region, which occur over a period of two to seven years. This change in ocean temperature and current affects atmospheric circulation and weather patterns globally. The impacts of ENSO can be significant and can have widespread effects on ecosystems, agriculture, and human activities.

### 'YO SOY EL NIÑO'

The phenomenon of El Niño was first observed centuries ago by fishermen off the coast of Peru, who noticed occasional periods of abnormally warm waters that would reduce the abundance of fish. This phenomenon was dubbed El Niño, a Spanish language reference to the Christ child, because it typically began to appear around Christmas.

As better weather records became available for the South Pacific during the 19th Century, a consistent negative correlation was noticed between atmospheric pressure in the western and central South Pacific – high pressure and drought conditions recorded at Darwin in the Northern Territory of Australia often coincided with low pressure and wet conditions in French Polynesia (near the center of the South Pacific). This phenomenon was first documented by British climatologist Sir Gilbert Thomas Walker and named the Southern Oscillation. Further work by Walker showed that the impacts of the Southern Oscillation extended far beyond the South Pacific, with statistical evidence that climate anomalies around the world were associated with it.

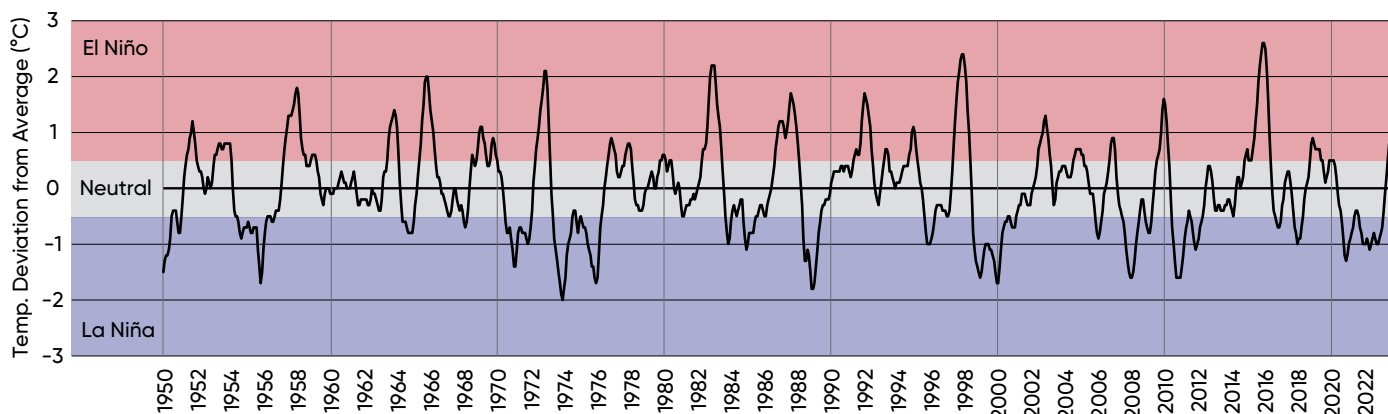
○ *"ENSO follows a regular cycle, but the timing and pattern of the cycle can vary considerably."*



**Figure 1.** Sea surface temperature across the tropical Pacific Ocean in December 1988 (top) during a strong La Niña and in December 1997 (bottom), during a strong El Niño.

Maps by NOAA Climate.gov, based on data from NOAA's Physical Science Lab.

It wasn't until the 1960s that meteorologist Jacob Bjerknes recognized that El Niño and the Southern Oscillation were actually components of the same large interacting system of atmospheric and ocean circulation, now referred to as the El Niño Southern Oscillation. Scientific interest and study of ENSO increased following the strong El Niño event of 1982-1983 and it entered the popular consciousness in the 1990s following a rapid succession of El Niño events and one particularly memorable Saturday Night Live sketch in 1997.



**Figure 2.** Oceanic Niño Index (ONI) values from January 1950 through July 2023, showing 3 month running mean of sea surface temperature anomalies in the Niño 3.4 region, based on centered 30-year base periods updated every 5 years.

NOAA National Weather Service Climate Prediction Center, [https://origin.cpc.ncep.noaa.gov/products/analysis\\_monitoring/ensostuff/ONI\\_v5.php](https://origin.cpc.ncep.noaa.gov/products/analysis_monitoring/ensostuff/ONI_v5.php)

## ENSO PHASES

El Niño is the most well-known of the three phases of the El Niño Southern Oscillation, which also includes its opposite phase La Niña and a neutral phase. El Niño is not necessarily more important or impactful than La Niña; it is more well-known because it was the part of the cycle that was discovered and named first.

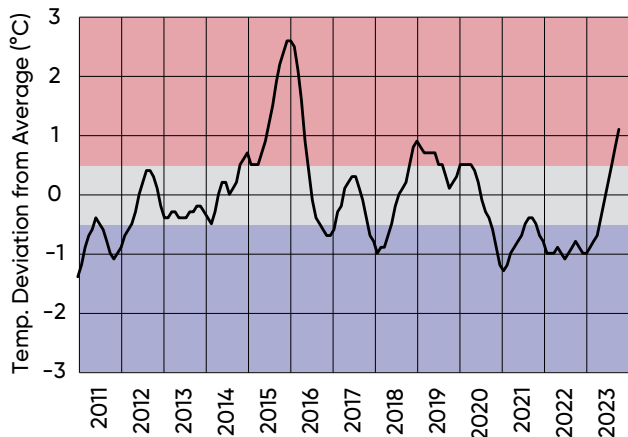
**Neutral phase:** This is the normal state of the tropical Pacific, where the trade winds blow from east to west, causing warm surface water to accumulate in the western Pacific and cooler water to upwell in the eastern Pacific. During this phase, sea surface temperatures are relatively stable.

**El Niño phase:** During an El Niño event, the trade winds weaken, and the warm surface water in the western Pacific flows back towards the east, causing sea surface temperatures to rise in the eastern Pacific. This results in changes in atmospheric circulation and weather patterns globally, such as droughts in Southeast Asia and Australia and wetter conditions in western South America.

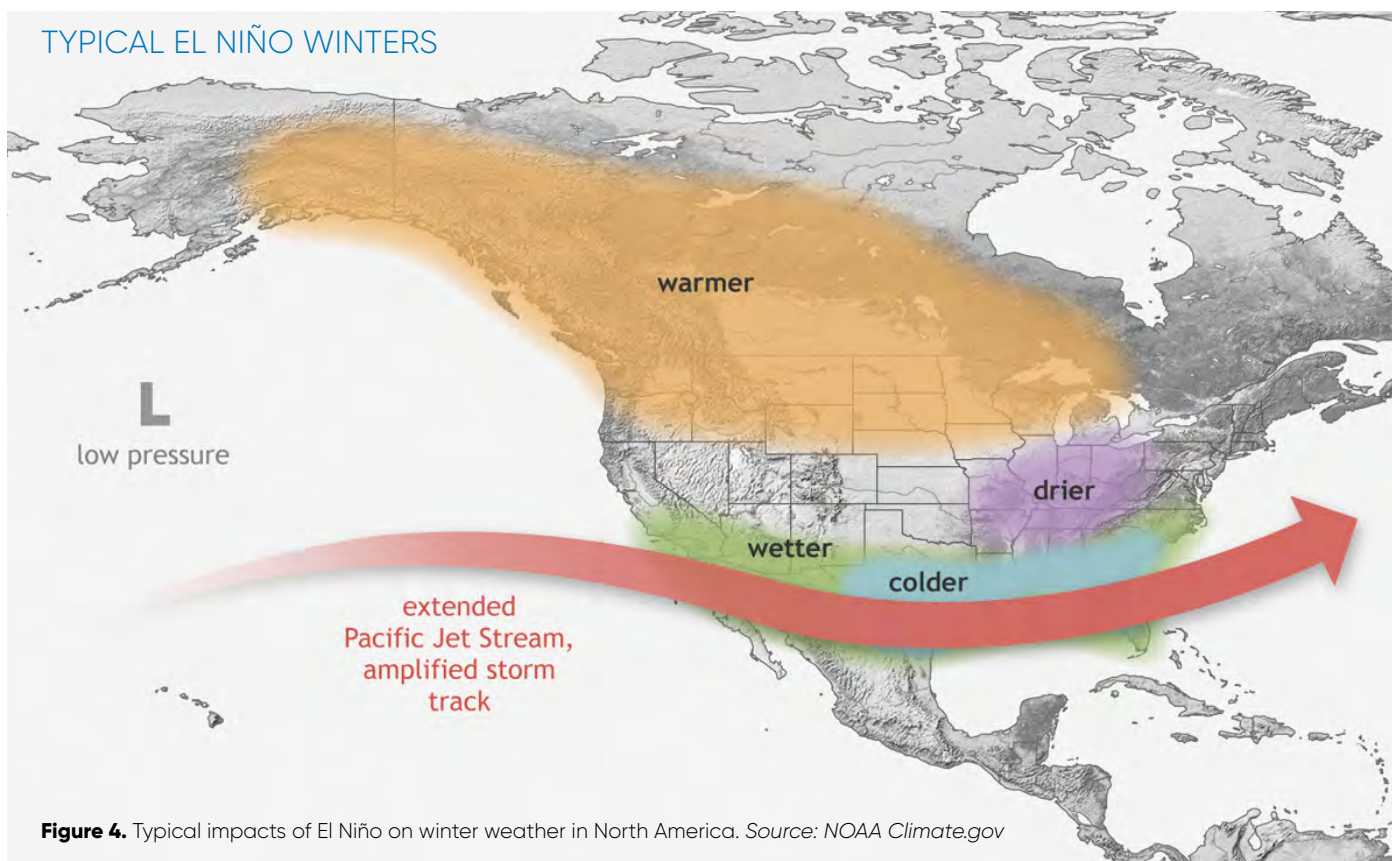
**La Niña phase:** During a La Niña event, the trade winds strengthen, causing even more warm water to accumulate in the western Pacific and cooler water to upwell in the eastern Pacific. This leads to cooler sea surface temperatures in the eastern Pacific and affects atmospheric circulation and weather patterns differently than during El Niño events.

## MONITORING ENSO

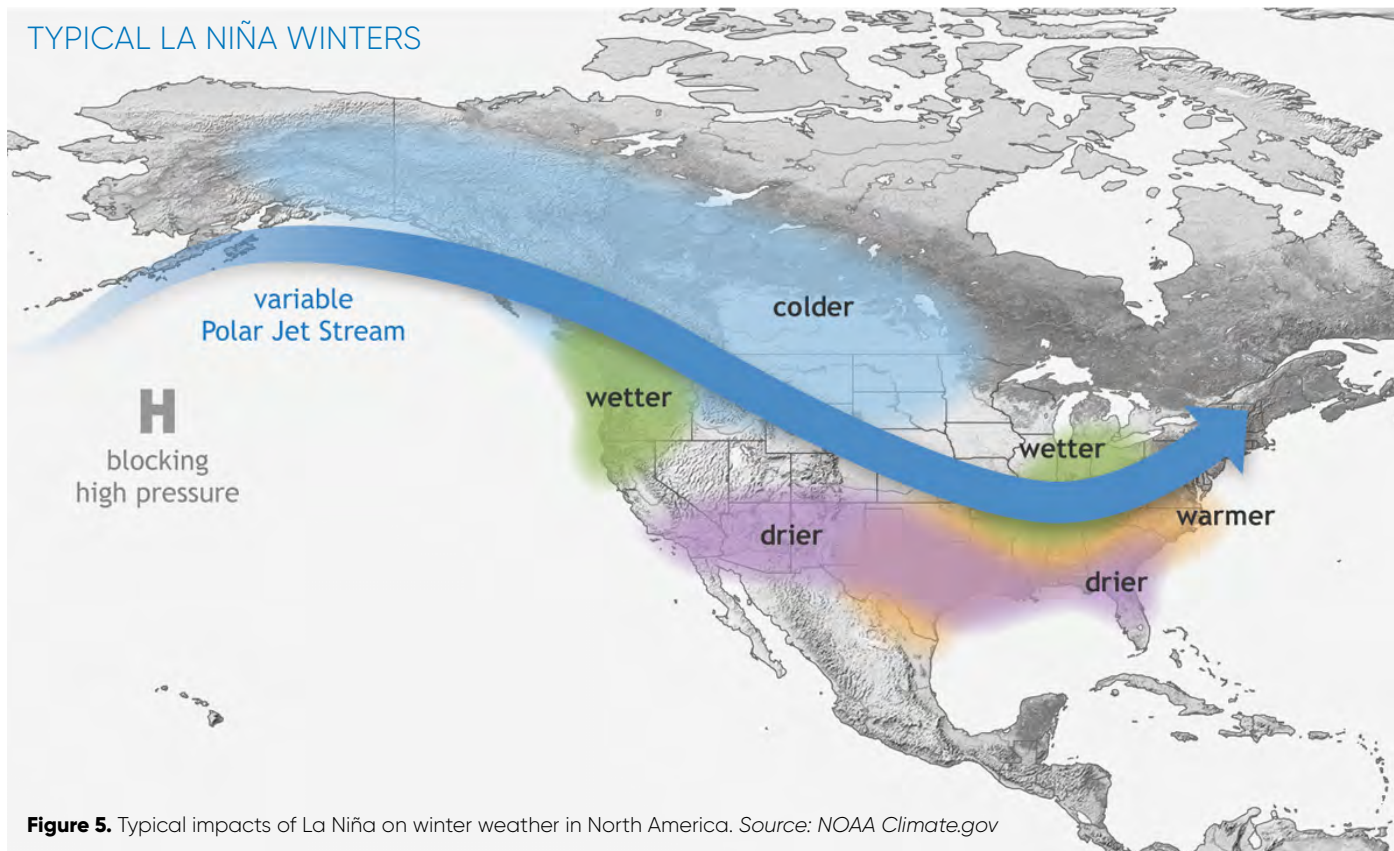
El Niño and La Niña events can vary in strength. The ocean temperature component of ENSO is characterized by the Oceanic Niño Index, which is a three-month rolling average of sea surface temperatures in the east-central region of the equatorial Pacific (Figure 2). Temperatures within  $\pm 0.5^\circ\text{C}$  of the 30-year average are considered neutral, more than  $0.5^\circ\text{C}$  above average is considered El Niño conditions and  $-0.5^\circ\text{C}$  or lower is considered La Niña. The greater the deviation from average, the stronger the El Niño or La Niña event is considered to be. The strongest El Niño event in recent history occurred during the winter of 2015–2016 when the ONI peaked above  $+2.5^\circ\text{C}$  from November through January, and the strongest recent La Niña was in winter of 2010–2011 with a peak of  $-1.6^\circ\text{C}$  from September through December 2010.



**Figure 3.** Oceanic Niño Index (ONI) values from 2011–2023, showing the most recent El Niño phases in 2015–2016 and 2018–2019, the extended La Niña phase that began in 2020 and continued through early 2023, and the shift to El Niño that occurred in mid-2023.



**Figure 4.** Typical impacts of El Niño on winter weather in North America. Source: NOAA Climate.gov



**Figure 5.** Typical impacts of La Niña on winter weather in North America. Source: NOAA Climate.gov

ENSO follows a regular cycle, but the timing and pattern of the cycle can vary considerably, with the time between El Niño events ranging from two to seven years in most cases. Episodes of El Niño and La Niña typically last nine to 12 months but can sometimes last for years.

El Niño and La Niña events typically reach their peak strength during the late fall or early winter months in the tropical Pacific Ocean when sea surface temperatures in the central and eastern equatorial Pacific Ocean are at their warmest and coolest, respectively. While the peaks may occur during this period, the impacts of El Niño and La Niña on global weather patterns, including changes in precipitation and temperature, can extend into the following months, affecting various regions around the world. The specific timing and intensity of El Niño events can vary from one occurrence to another, and their effects on weather patterns can also be influenced by other atmospheric and oceanic factors.

### IMPACTS ON WEATHER IN NORTH AMERICA

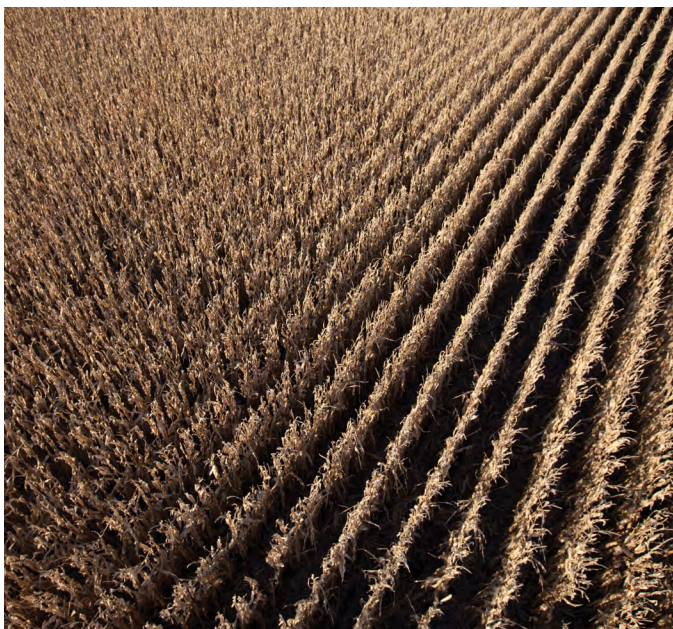
ENSO has significant impacts on weather patterns around the world, including North America. El Niño and La Niña have their strongest influence on U.S. seasonal climate during winter. The effects of the El Niño phase on North America can vary depending on the strength and timing of the El Niño event, but common impacts include:

- Increased rainfall in the southern U.S., particularly in the winter months. This can lead to flooding in some regions (Figure 4).
- Warmer-than-average temperatures in the northern U.S. and Canada during the winter months.

- Drier and warmer conditions in the Pacific Northwest and parts of the Midwest, which can lead to drought conditions and an increased risk of wildfires.
- Milder winters to the northern U.S., reducing the chances of heavy snowfall and colder temperatures in regions like the Midwest and Northeast.
- Suppression of Atlantic hurricane activity, reducing the number and intensity of hurricanes in the Atlantic Basin.

La Niña is the counterpart to El Niño and its climate impacts tend to be the opposite of the El Niño phase of the cycle. Common impacts of La Niña on the climate of North America include:

- Wetter-than-average conditions in the northern U.S., particularly in the Pacific Northwest and northern Rockies during the winter months. This can result in above-average snowfall (Figure 5).
- Colder-than-average temperatures in the northern U.S. during the winter. This can lead to prolonged periods of wintry weather.
- Drier conditions in the southern U.S., including the Southwest, Southern Plains, and Southeast. This can result in drought conditions, reduced water availability, and an increased risk of wildfires.
- Increased likelihood of an active Atlantic hurricane season. Warmer waters in the tropical Atlantic can fuel the development of hurricanes, potentially affecting the Gulf of Mexico and the southeastern U.S.
- Enhanced potential for severe weather outbreaks, including tornadoes, in the southern and central United States during the spring.



## IMPACTS ON CROP PRODUCTION

ENSO is a major source of climate variability that has impacts on crop production regions around the world, and numerous studies have examined its effects on regional and global crop yields. In the U.S. and Canada, yields of summer annual crops such as corn and soybean tend to be less affected because the strongest effects of ENSO do not occur during the growing season.

In general, ENSO-related temperature and precipitation impacts across the U.S. and Canada occur during the cold

half of the year – October through March. Usually, El Niño or La Niña episodes attain peak strength in autumn or early winter, and the most reliable climate impacts in the U.S. and Canada are during winter, often a few months after the peak. ENSO effects during summer are mostly weak or insignificant; however, they can be more substantial and consistent in other regions of the globe.

*"El Niño and La Niña episodes usually attain peak strength in autumn or early winter and the most reliable climate impacts in the U.S. and Canada are during winter."*

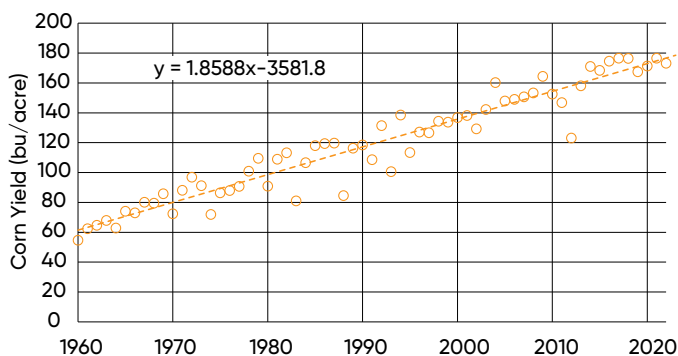
Effects on weather during the winter and early spring can have important effects on conditions going into the start of the summer growing season. For example, recharge of water in the soil profile following a drought and overwintering of insect pests are both factors that are affected by temperature and precipitation patterns during the winter. However, temperature and precipitation during the summer months – which are the greatest drivers of yield – are not as directly and consistently affected.

## CORN AND SOYBEAN YIELD TRENDS

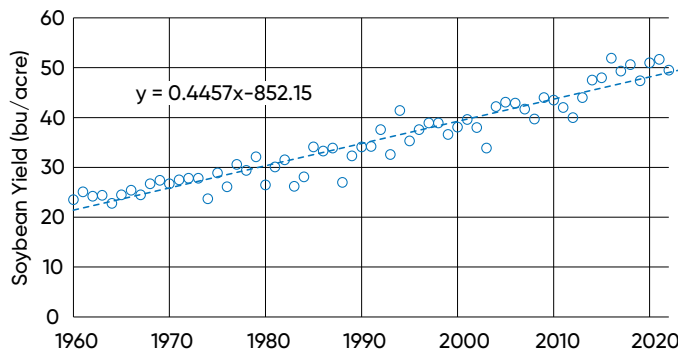
A 2016 analysis by the University of Illinois (published during the last major El Niño event) looked at the impacts of El Niño on U.S. corn and soybean yields the following season (Irwin and Good, 2016a; Irwin and Good, 2016b). The authors calculated the deviation of yearly corn and soybean yields from the long-term trendline and summarized numbers for crop years following strong El Niño events ( $>1.0^{\circ}$  C ONI) to see if yields tended to be above or below trendline in those years. Results suggested a slightly elevated risk of below trendline yields following an El Niño event for both corn and soybeans on average, but results varied widely, with yields above trendline occurring with about the same frequency as below trendline.

The following charts and tables provide an update and expansion of the University of Illinois analysis to include crop years up through 2022 and a summary of yield trends following both El Niño and La Niña events. Figures 6 and 7 show U.S. average yields from 1960 to 2022 for corn and soybean, respectively. Yields of both crops increased linearly over this period, by an average of 1.86 bu/acre/yr for corn and 0.45 bu/acre/yr for soybean.

Tables 1 and 2 show corn and soybean yield deviations from the 1960–2022 trendlines (calculated as percentage above or below) for growing seasons following strong El Niño and La Niña events.



**Figure 6.** Average U.S. corn yields, 1960–2022. Source: USDA National Agricultural Statistics Service.



**Figure 7.** Average U.S. soybean yields, 1960–2022. Source: USDA National Agricultural Statistics Service.

Tables 1 and 2 also show the peak ONI temperature for each event and the month or months in which that temperature peak was recorded. In some cases, that peak temperature was sustained for multiple months, sometimes extending from the end of one year into the beginning of the next.

Results show yields slightly below trendline on average for both corn and soybean following both El Niño and La Niña events. However, much like the University of Illinois analysis, results show a mixed picture, with above trendline yields occurring with around the same frequency as below trendline.

*"ENSO phase is not strongly predictive of U.S. corn and soybean yield performance in the subsequent growing season."*

**Table 1.** El Niño events exceeding +1.0° C ONI from 1960 to present, and U.S. corn and soybean yield deviations (%) from trendline yield in the following crop year.

El Niño Event	Peak Temp. Dev.	Peak Months	Crop Year	Yield Dev. From Trend	
				Corn	Soy
	°C			- % -	
1963-64	1.4	Nov 63	1964	-8.7	-1.7
1965-66	2	Oct - Nov 65	1966	0.7	5.4
1968-69	1.1	Jan - Feb 69	1969	9.9	7.7
1972-73	2.1	Nov - Dec 72	1973	6.6	2.1
1982-83	2.2	Nov 82 - Jan 83	1983	-22.2	-17.3
1986-87	1.2	Dec 86 - Feb 87	1987	7.3	1.3
1987-88	1.7	Aug 87	1988	-25.5	-20.4
1991-92	1.7	Jan 92	1992	8.7	5.4
1994-95	1.1	Dec 94	1995	-10.3	-4.7
1997-98	2.4	Nov - Dec 97	1998	1.8	1.4
2002-03	1.3	Nov 02	2003	0.6	-16.5
2009-10	1.6	Dec 09	2010	-1.2	-0.5
2015-16	2.6	Nov - Dec 15	2016	5.5	11.9
<b>Average Deviation from Trendline Yield</b>				<b>-2.1</b>	<b>-2.0</b>
<b>Number of Years Above Trendline</b>				<b>8</b>	<b>7</b>
<b>Number of Years Below Trendline</b>				<b>5</b>	<b>6</b>

The worst years for corn yields since 1960, in which average yield was more than 10% below trendline, included three El Niño years (1983, 1988, 1995), two La Niña years (1974, 2012), and two neutral years (1960, 1993). The best corn yield years (more than 10% above trendline) included one La Niña year (1972), and four neutral years (1979, 1982, 1994, 2004).

For soybean, the worst yield years included three El Niño years (1983, 1988, 2003), three La Niña years (1974, 1984, 2012), and one neutral year (1980). The best years included one El Niño year (2016), and two neutral years (1961, 1994).

Overall, results show that ENSO phase is not strongly predictive of U.S. corn and soybean yield performance in the subsequent growing season.

**Table 2.** La Niña events below -1.0° C ONI from 1960 to present, and U.S. corn and soybean yield deviations (%) from trendline yield in the following crop year.

El Niño Event	Peak Temp. Dev.	Peak Months	Crop Year	Yield Dev. From Trend	
				Corn	Soy
	°C			- % -	
1970-71	-1.4	Jan - Feb 71	1971	7.6	4.5
1971-72	-1	Nov 71	1972	15.8	3.8
1973-74	-2	Dec 73	1974	-17.8	-14.3
1975-76	-1.7	Dec 75	1976	-3.5	-8.6
1983-84	-1	Nov 83	1984	0.6	-12.5
1984-85	-1.1	Dec 84	1985	9.3	4.7
1988-89	-1.8	Nov - Dec 88	1989	0.8	-6.0
1995-96	-1	Oct - Dec 95	1996	-1.0	0.4
1998-99	-1.6	Dec 98	1999	-0.1	-5.7
1999-00	-1.7	Dec 99 - Jan 00	2000	0.8	-2.9
2007-08	-1.6	Dec 07 - Jan 08	2008	1.7	-7.3
2010-11	-1.6	Sept - Dec 10	2011	-6.0	-4.9
2011-12	-1.1	Nov 11	2012	-22.1	-10.3
2020-21	-1.3	Nov 20	2021	1.1	6.4
2021-22	-1	Nov 21 - Jan 22	2022	-1.9	0.9
2022-23	-1	Sept - Oct 22	2023		
<b>Average Deviation from Trendline Yield</b>				<b>-0.7</b>	<b>-2.8</b>
<b>Number of Years Above Trendline</b>				<b>9</b>	<b>7</b>
<b>Number of Years Below Trendline</b>				<b>7</b>	<b>9</b>



# High Temperatures Increase Water Stress in Corn

Mark Jeschke, Ph.D., Agronomy Manager

## KEY POINTS:

- Higher temperatures cause the transpiration rate of plants to increase, placing a greater demand on soil water supply and accelerating the onset of drought stress.
- The increased water demand under extreme heat is substantial – raising temperature from 80° F to 95° F (27° C to 35° C) causes water demand to double
- Corn plants respond to water stress by closing their stomates, which helps preserve water but also reduces the CO<sub>2</sub> intake needed for photosynthesis.

## EXTREME HEAT INCREASES WATER STRESS

- High temperatures can impact corn directly by reducing pollination and net photosynthesis, but the greater impact comes through the interaction of heat and water stress.
- Higher temperatures create a higher vapor pressure deficit (VPD) between the saturated leaf interior and the ambient air.
- This causes the transpiration rate of plants to increase, placing a greater demand on soil water supply and potentially accelerating the onset of drought stress.

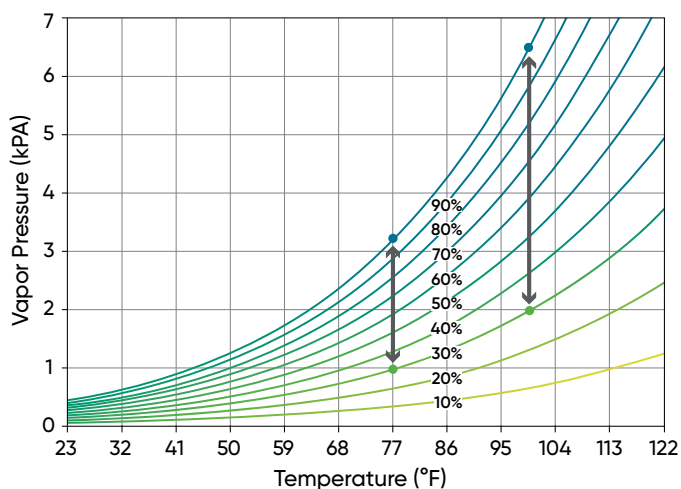


**Figure 1.** Corn showing the effects of extreme heat and drought stress in central Iowa in 2012.

## VAPOR PRESSURE DEFICIT

- Vapor pressure deficit (VPD) combines relative humidity (RH) and temperature into a single variable to describe the evaporative potential of the atmosphere.
- Air space in the interior of living plant tissue is essentially fully saturated with water (100% RH).
- Water vapor moves from an area of higher concentration to an area of lower concentration.

- As long as the ambient air is less than 100% humidity, it will pull water out of plant leaves, driving transpiration of water through the plant.
- The greater the vapor pressure deficit between the leaf interior and the surrounding air, the faster the rate at which water will be pulled out of the plant and evaporated.
- Temperature is important to this equation because VPD increases exponentially with increasing temperature, even if relative humidity stays constant (Figure 2).



**Figure 2.** Vapor pressure for water by relative humidity and temperature. As temperature rises, the difference in vapor pressure between the interior of plant leaves and the ambient air increases.

## CORN RESPONSE TO HIGH VAPOR PRESSURE DEFICIT

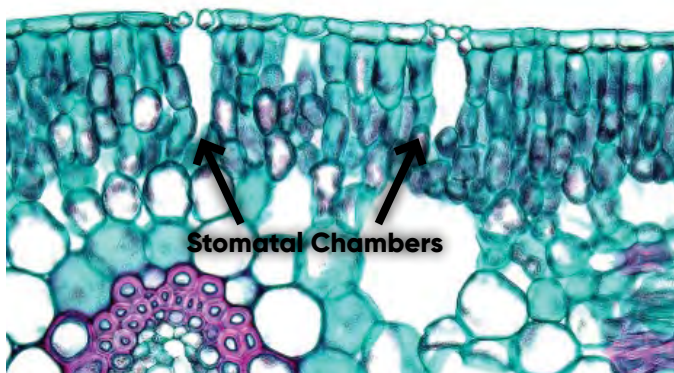
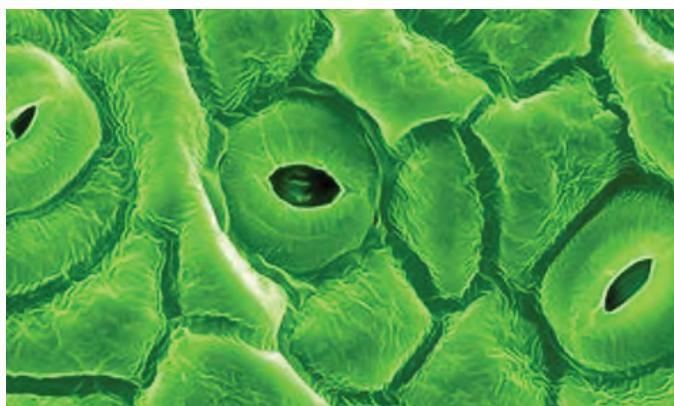
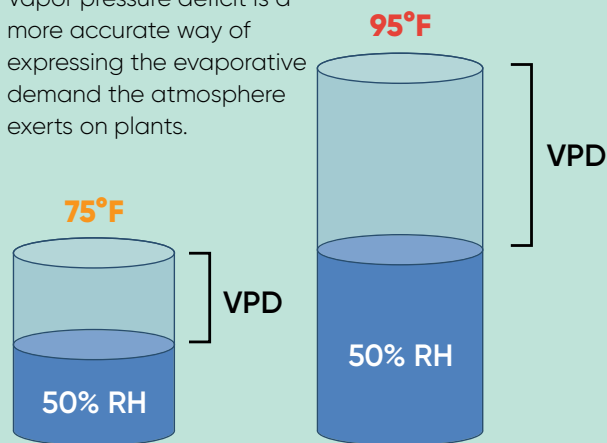
- Corn plants respond to higher VPD by closing their stomates, which helps preserve water for periods when evaporative demand is lower (Figure 3).
- Reduced stomatal conductance also reduces the rate at which plants are able to take in CO<sub>2</sub>, which lowers the rate of photosynthetic carbon fixation during high-VPD portions of the day.
- Field experiments conducted in an environment in which temperatures reached daily highs in the mid-90s (°F) showed reduced photosynthesis and growth of corn associated with high VPD (Hirasawa and Hsiao, 1999).
- On days with high atmospheric VPD, photosynthetic rate and stomatal conductance peaked during late-morning and then declined throughout the afternoon as temperature and VPD continued to climb (Figure 4).
- Even in irrigated plots, this afternoon depression in photosynthetic rate was apparent, although decline was much greater in non-irrigated plots (Figure 5).

### Vapor Pressure Deficit vs. Relative Humidity

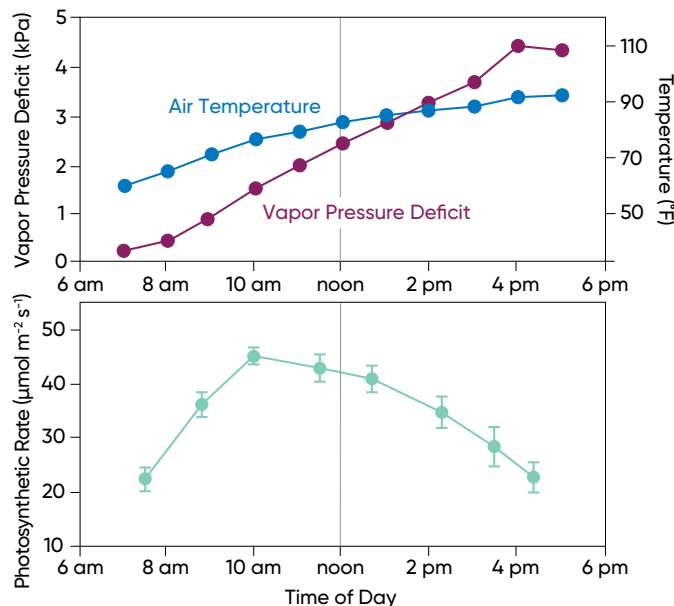
How does VPD differ from relative humidity? Relative humidity refers to the amount of water vapor in the air versus what it can hold; however, the amount of water air can hold varies with temperature.

If you think of the atmosphere as a container holding water, that container gets bigger as temperature increases so it takes more water to fill it.

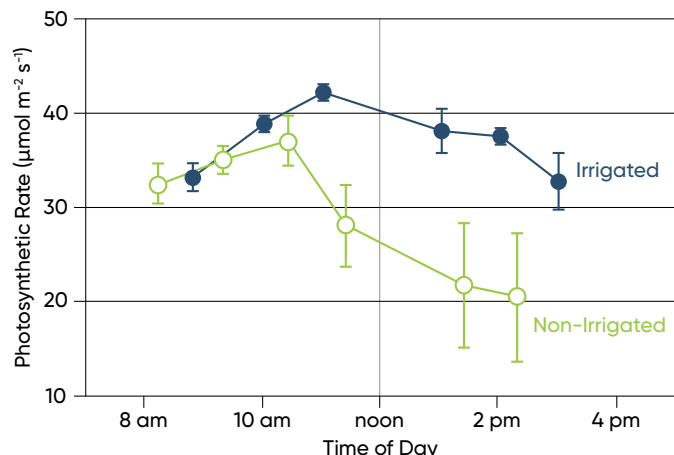
Vapor pressure deficit is a more accurate way of expressing the evaporative demand the atmosphere exerts on plants.



**Figure 3.** Stomatal pores and stomatal chambers. Stomatal pores allow for the exchange of water and CO<sub>2</sub> between the atmosphere and leaf internal structures. Stomatal chambers serve as locations where liquid water converts to water vapor and escapes into the atmosphere. There are approximately 36,000 stomates/in<sup>2</sup> on the upper surface and 50,000 stomates/in<sup>2</sup> on the lower surface of a corn leaf.



**Figure 4.** Air temperature, atmospheric vapor pressure deficit, and leaf photosynthetic rate in irrigated corn over the course of a day (Hirasawa and Hsiao, 1999).



**Figure 5.** Leaf photosynthetic rate by time of day for irrigated and non-irrigated corn (Hirasawa and Hsiao, 1999).

### EXTREME TEMPERATURES INCREASE VPD

- The increased water demand under extreme heat is substantial – raising temperature from 80° F to 95° F (27° C to 35° C) causes water demand to double (Lobell et al., 2013).
- The damage caused by extreme heat can be partially mitigated by increased precipitation, but not eliminated (Roberts et al., 2013).
- Lobell et al. (2013) compared the water stress effect caused by a 20% reduction in precipitation over a month-long period with that caused by a 2° C increase in temperature over the same time period and found that increased temperature had a greater impact on water stress than reduced precipitation.
- Total seasonal rainfall was found to have a relatively weak relationship with corn yield, indicating that water demand can matter as much or more than water supply.

# Field Edge Effects in Corn

Mark Jeschke, Ph.D., Agronomy Manager

Photos courtesy of Alex Woodall, Pioneer Field Agronomist

## KEY POINTS:

- → Reduced corn yield along field edges can be associated with the effect of incoming winds on the microclimate within the field.
- → Hot, dry air hitting the leading edge of a field increases evaporative demand and amplifies heat and drought stress along the field edge.
- → The air picks up more moisture as it moves across the field, so plants in the interior experience less stress than those on the edge.

## LOWER PERFORMANCE ALONG FIELD EDGES

There are a number of factors that can cause corn yields to be lower along the edges of a field:

- Insect populations that move in from fence rows.
- Herbicide drift from neighboring fields.
- Soil compaction in the end rows, especially in areas that have heavy traffic during harvest.
- In some cases, poor performance is specifically associated with exposure of the field edge to wind.
- Edges adjacent to a road or a shorter crop, such as soybeans, that are directly exposed to wind fare worse than edges along another corn field that have a greater degree of protection.
- Poor performance is more frequently observed on the southern and western edges of fields (Figure 1).



**Figure 1.** Corn field showing stress symptoms along the western edge of the field, with soybeans in the neighboring field (September 2021).

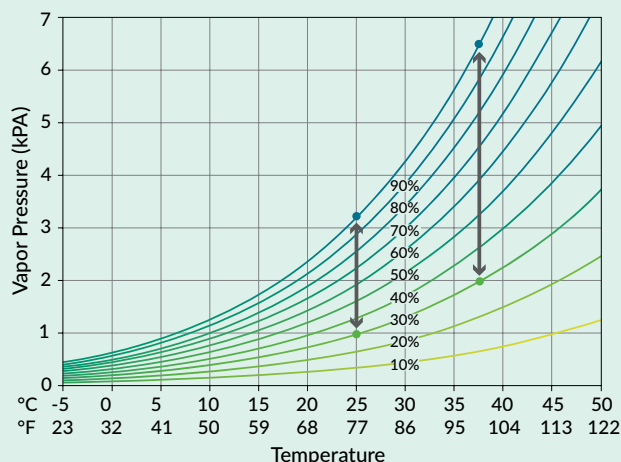
- In cases where herbicide drift can be ruled out, the edge effect is likely associated with incoming winds affecting the microclimate within the field.
- Particularly in hot and dry summers, arid winds can amplify heat and drought stress along exposed edges of the field.

## HEAT AND DROUGHT STRESS

- Vapor pressure deficit (VPD) is the difference between how much water the air can hold when it is saturated and how much water it currently holds.
- Higher temperatures increase crop water demand by creating a higher VPD between the saturated leaf interior and the ambient air.
- Air space in the interior of living plant tissue is essentially fully saturated with water.
- The greater the vapor pressure deficit between the leaf interior and the surrounding air, the faster the rate at which water will be pulled out of the plant and evaporated.
- Extreme heat dramatically increases water demand – raising temperatures from 80° F to 95° F (27° C to 35° C) causes water demand to double (Lobell et al., 2013).

### Vapor Pressure Deficit and Temperature

- Extreme heat dramatically increases water demand because VPD increases exponentially with increasing temperatures, even as relative humidity (RH) stays constant.
- For example, if the RH of ambient air is 30%, the VPD will be much greater at 100° F (38° C) than at 77° F (25° C), creating a much higher evaporative demand at the higher temperature (Figure 2).

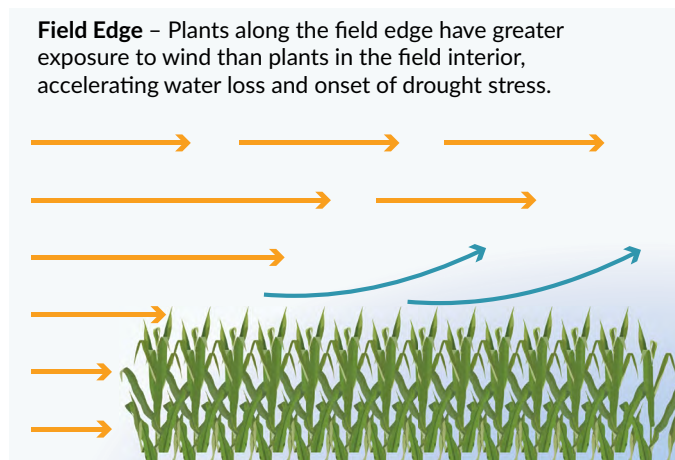
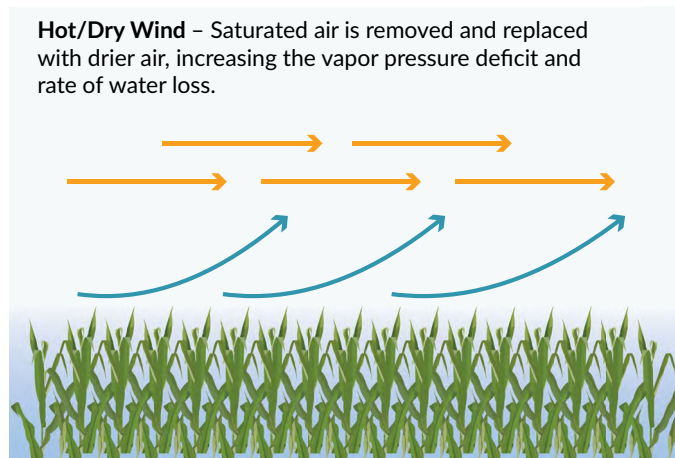
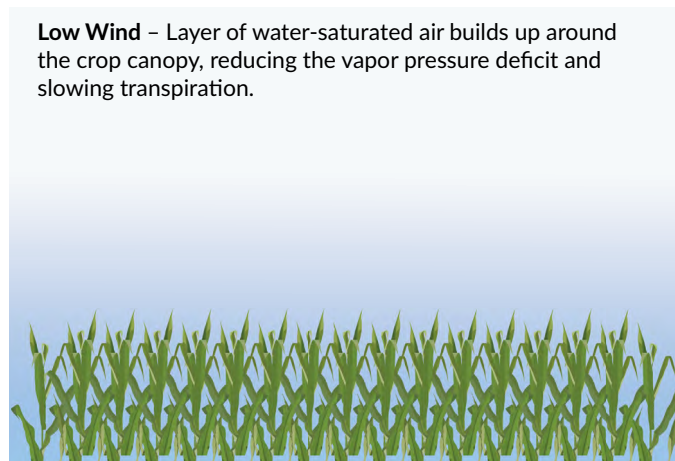


**Figure 2.** Vapor pressure for water by relative humidity and temperature.



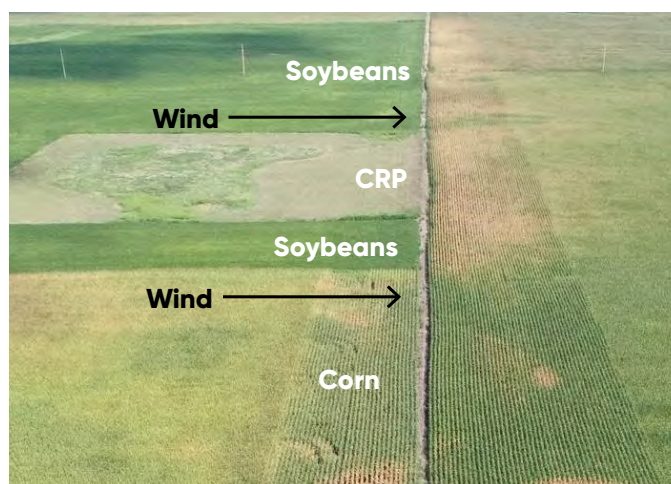
## WIND INCREASES STRESS

- Wind can exacerbate heat stress by increasing the vapor pressure deficit (VPD) between the leaves and the air immediately surrounding them.
- When water is evaporated from plant leaves, the air above the surface gradually becomes more saturated with water vapor.



**Figure 3.** Illustration of the effect of arid wind on the microclimate of the crop canopy.

- If winds are low, this layer of saturated air stays in place around the crop canopy, causing the evapotranspiration rate to decrease (Figure 3).
- When winds are high, this layer of saturated air is constantly being removed and replaced with drier air (Allen et al., 1998).
- At high relative humidity, wind speed will matter less, as the wind will only be able to replace the saturated air with slightly less saturated air.
- Under arid conditions, small variations in wind speed may result in large variations in VPD and evapotranspiration.
- The more severe stress along the field edge is likely due to the fact that the air is driest when it encounters the leading edge of the field and picks up moisture as it moves across the crop canopy (White and Licht, 2020; Westgate and Vittetoe, 2017).
- Consequently, the effect of wind on VPD is greatest for plants near the field edge and lower for plants in the rest of the field (Figure 4).



**Figure 4.** Corn field showing stress symptoms along the edge of the field where it is bordered by soybeans and conservation reserve program land (CRP), but no symptoms where it is bordered by corn (September 2021).

## IMPACT ON CORN PLANTS

- Corn plants respond to higher VPD by closing their stomata, which helps preserve water, but also reduces the rate at which plants take in  $\text{CO}_2$ , which lowers the rate of photosynthesis and decreases yield.
- Greater evaporative demand also increases the rate at which the soil water supply is depleted, which can cause longer-term stress on the crop.
- Plants on field edges may be at greater risk for sunscald, which occurs when evaporative demand increases faster than the plant is able to respond, causing leaf tissue to die.

# High Humidity Can Disrupt Pollen Shed in Corn

Mark Jeschke, Ph.D., Agronomy Manager

## ○ KEY POINTS:

- → Anthers on the tassels of corn plants need to be dry in order to release pollen.
- → Peak pollen shed typically occurs mid-morning when rising temperatures cause the relative humidity to drop and the dew on the plant evaporates.
- → On days when cool, wet conditions or high humidity prevent the anthers from drying out, pollen shed may be delayed until later in the day or may not occur at all.

## POLLINATION PERIOD IN CORN

- Pollen shed across a corn field typically lasts 10 to 14 days, with around a 4-day period when pollen shed is at its peak.
- Pollen shed from an individual plant occurs over a shorter period – typically not more than seven days.
- Peak pollen shed from an individual plant typically occurs on the second and third day and then tapers off.
- Not all plants begin shedding pollen at the same time, which is why the total pollination period lasts longer than that of individual plants.
- Plant-to-plant variability in the timing of peak pollen shed, along with the sheer volume of pollen produced (estimates range from 2 to 25 million grains per plant), provide a margin of safety for achieving complete pollination.
- Even if unfavorable conditions disrupt pollination for a few days, there is usually enough time and pollen available to complete pollination without issue.
- However, when unfavorable conditions persist for more than a few days, it is possible that incomplete pollination can result.



**Figure 1.** Corn plants across a field do not all reach pollination at exactly the same time, so the pollination period for the field is longer than that of an individual plant.



**Figure 2.** Each tassel has around 1,000 individual spikelets and each one contains two florets encased in two large glumes. Each floret contains three anthers. Pollen shed begins in the middle of the central tassel spike and then progresses outward (Nielsen, 2018).

## WHAT FACTORS CAN DISRUPT POLLINATION?

- Incomplete pollination can result from issues on the receiving end; e.g., there is plenty of pollen released but the silks are unable to receive it.
- Heavy feeding on silks by insects, such as corn rootworm beetles or Japanese beetles, is one factor that can prevent the silks from receiving pollen.
- Extreme drought stress during silking can delay silk emergence until after peak pollen shed, referred to as “missing the nick.”
- Problems can also occur on the sending end that prevents viable pollen from reaching receptive silks.
- Extreme heat during pollen shed can desiccate pollen grains before they reach silks.
- Prolonged wet and humid conditions can also cause problems. Anthers on the tassel need to be dry to release pollen. If they cannot dry out, pollen shed cannot occur.



**Figure 3.** Close-up view of anthers on a corn tassel showing the outward bend at the tips of the locules, creating an opening for pollen to escape.

### MECHANISM OF POLLEN SHED

- Pollen release from anthers requires two events. First, pollen grains mature inside anthers. Secondly, pores of anthers open to release pollen, a process called dehiscence.
- The opening of the anthers and subsequent pollen release is initiated by the desiccation of the anther tips (Aylor et al., 2003).
- Each anther is comprised of four pieces called locules that are held together by a thin membrane of tissue called the septum.
- Shortly before dehiscence, the four locules will fuse together in pairs, forming two locules.
- As the tips of the two locules dry, they bend outward, creating a pore through which pollen is released (Figure 3).
- Evaporation of water from the anther, as well as active retraction of water by the plant, may play a role in anther desiccation and pollen shed (Bonner and Dickinson, 1990; Heslop-Harrison et al., 1987).
- This process is reversible – if the anther is rewetted, the locules will unbend and the pore will close. Additionally, and if ambient conditions such as high humidity or rain prevent the anther from drying out, it will not open at all.
- Under wet and windy conditions, anthers may fall to the ground without ever opening to release their pollen.

#### Some Important Terms:

**Anther:** In flowering plants, the part of a stamen that produces and contains pollen.

**Exsertion:** The pushing out of the anthers from inside the florets.

**Dehiscence:** The splitting of a mature plant structure along a built-in line of weakness to release its contents; in this case, the anther and pollen.

**Diurnal:** A process that cycles over a 24-hour day.

### POLLEN SHED OCCURS ON A DIURNAL CYCLE

- The dependence of pollen shed on anther desiccation means it tends to follow a diurnal cycle, with peak pollen shed occurring in the morning when rising temperatures and falling humidity dry the dew off the plant.
- The exact timing of peak pollen shed can vary from day to day depending on weather conditions.
- A Corteva Agriscience field study that tracked pollen shed in a corn field over a period of four days in 2021 found that pollen shed peaked before 10:00 a.m. on two of the days and after 10:00 on the other two days, and that the timing roughly corresponded with the time at which the morning dew was completely evaporated (Strachan, 2022).
- In some cases, pollen shed has been shown to have a bimodal pattern with a large peak mid-morning, followed by a lull, then a subsequent smaller peak two to three hours later (van Hout et al., 2008).
- In cases where a second peak is observed, it appears to be associated with an increase in wind turbulence.



**Figure 4.** Corn anthers and pollen grains on a leaf. Anthers drop off of the tassel once their pollen has been released.

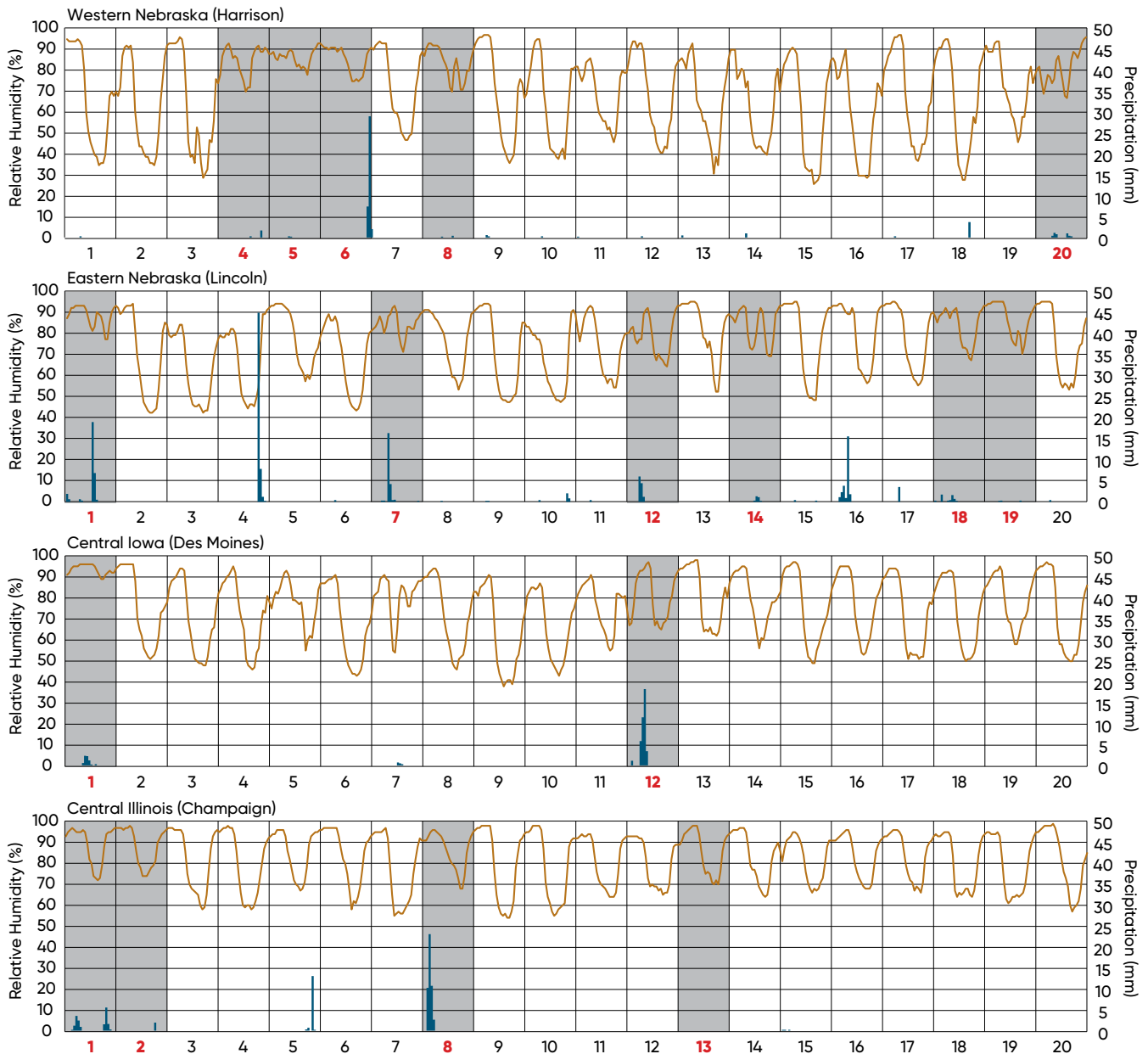
### EFFECT OF AMBIENT CONDITIONS ON DEHISCENCE

- Although it is well understood that drying out of the anthers is necessary for pollen shed, the effect of ambient conditions on this process is complex and can involve multiple factors.
- Consequently, it has been difficult to pin down exact temperature or relative humidity thresholds necessary for pollen shed to occur.
- One field study conducted to address this question found that the initial morning release of pollen was related to a decrease in relative humidity that raised vapor pressure deficit (VPD) values to 0.2-0.5 kPa around the anthers (Jarosz et al., 2005). (At an air temperature of 65°F, a VPD range of 0.2-0.5 kPa would correspond to a relative humidity range of 75-90%.)
- Wind can affect the rate of anther drying and the physical movement it creates helps disperse pollen.
- Direct solar radiation also appears to play a role in drying of the anthers and pollen release (van Hout et al., 2008).
- Cool, cloudy, and high humidity conditions can lead to a temporary pause in pollen shed (Jackson and Lyford, 1999).

## HIGH HUMIDITY EFFECTS ON POLLINATION

- High humidity conditions can suspend pollen shed in corn, but does an extended period of high humidity have a serious impact on pollination?
- Corn has evolved characteristics to ensure complete pollination in most circumstances – plants produce way more pollen than is needed to pollinate the ears and the pollen is not all released at the same time – so there is some margin of safety even if conditions prevent pollen shed for a day or two.

- It is possible that an extended period of wet and humid conditions could disrupt pollen shed over a longer duration, but such a period would be unusual during the summer.
- Figure 5 shows hourly precipitation and relative humidity data for four Corn Belt locations from July 1-20, 2023.
- Precise thresholds for pollen shed are difficult to ascertain because of the multiple factors involved (only two of which are considered here). However, the charts below provide a look at humidity and precipitation during a 20-day period, as well as days when these factors could have potentially reduced pollen shed.



**Figure 5.** Hourly relative humidity and precipitation for four locations from July 1 to July 20, 2023. Days shaded in gray are days in which pollen shed could potentially have been reduced by rainy conditions or high humidity (>70%). Data from NOAA NCEI U.S. Climate Reference Network monitoring stations.

"Genetic and morphological analyses confirmed soybean gall midge to be a previously undescribed species, now named *Resseliella maxima*"

# Gall Midge in Soybeans

Mark Jeschke, Ph.D., Agronomy Manager

- Soybean gall midge is a new insect pest of soybeans first found in Nebraska in 2011 that has now spread into parts of several other states.
- Gall midge injury in soybean is a result of larval feeding, which occurs near the base of the plant. Prolonged feeding can cause the stem to break, resulting in plant death.
- Injury is generally most severe at field edges, which suggests that populations are moving in from adjacent fields planted to soybeans the previous season.
- Yield loss reports have ranged from a 1-2 bu/acre to nearly total yield loss depending on how early injury occurs and the severity of the infestation in certain areas of a field.
- In 2019, populations of a second gall midge species that feeds specifically on white mold-infected plant tissue were found in soybeans in Minnesota.
- Management recommendations for soybean gall midge are still in the process of being developed. Research on soybean variety susceptibility and foliar insecticide and seed treatment efficacy is currently underway.

## GALL MIDGE – A NEW PEST OF SOYBEAN

Soybean gall midge is a relatively new insect pest of soybean. Gall midge was first observed in soybeans in Nebraska in 2011. Initially, it appeared to be a relatively minor pest of soybeans, mostly confined to field margins and feeding on soybean plants that were already damaged or diseased. However, instances of greater infestation levels and damage to soybeans were observed beginning in 2018, with populations extending further into field interiors and feeding on otherwise healthy plants.

Very little was known up to this point about the biology of soybean gall midge, including exactly what species it was. Initial investigations identified gall midge observed in soybeans as belonging to the genus *Resseliella*, which included 15 species known to exist in the U.S., none of which were known to infest soybeans. Genetic and morphological analyses subsequently confirmed soybean gall midge to be a previously undescribed *Resseliella* species, now named *Resseliella maxima* (Gagne et al., 2019).



**Figure 1.** Gall midge larvae feeding in soybean stems. Iowa, August 3, 2018. Photo: Jessie Alt, Corteva Agriscience Research Scientist.

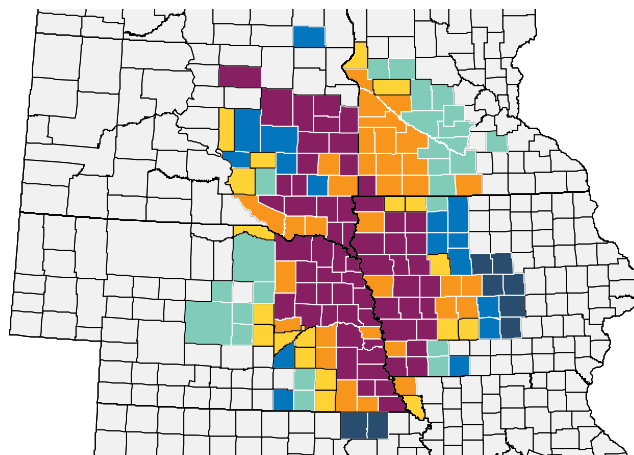
Soybean gall midge has now been confirmed in seven states and has proven capable of causing significant crop damage and reductions in yield. There is still much to be learned about the biology and lifecycle of this pest, as well as effective management practices. The situation was further complicated in 2019 with the discovery of a second gall midge species affecting soybeans in parts of Minnesota.

### FIELD OBSERVATIONS IN SOYBEANS

Gall midge damage in soybeans was first reported in Nebraska in 2011 in isolated cases mostly associated with damaged or diseased stems. Sporadic infestations were observed in subsequent years, but damage generally was not severe enough to impact yield. While remaining a relatively minor concern for soybean production, gall midge populations began to spread, with feeding in soybeans first reported in South Dakota in 2015 and western Iowa in 2016.

Pioneer agronomists and scientists at the University of Nebraska, Iowa State University, and South Dakota State University all noted increased infestation in 2018, with infestations occurring earlier in the season and causing

higher levels of damage to soybeans. Numerous infestations were observed in 2018 by Pioneer agronomists on otherwise healthy soybean plants, indicating that damaged or diseased tissue is not a necessary prerequisite for gall midge infestation. Economic levels of damage were observed again in 2019. The spread of soybean gall midge has continued, with populations reported in Missouri in 2019, North Dakota in 2022, Kansas in 2023, as well as the expansion of affected areas in Nebraska, Iowa, and South Dakota (Figure 2).



**Soybean Gall Midge (*Resseliella maxima*)**

Year of First Detection

2018 2019 2020 2021 2022 2023

**Figure 2.** Counties with documented infestations of soybean gall midge and year of first detection. (Source: [www.soybeangallmidge.org](http://www.soybeangallmidge.org))

### CHARACTERISTICS AND PLANT INJURY

Larvae are very small and start out white, turning bright red or orange as they mature (Figure 3). Adult midges are small (2-3 mm in length) and have long antennae and hairy wings (Figure 4). Gall midge injury in soybean is a result of larval feeding, which occurs near the base of the plant. Multiple larvae can infest a plant. Larvae feed inside the stem, causing swelling and abnormal growth (galls). Infested portions of the stem will appear swollen and brown (Figures 5 and 6). Discolorations of the stem often begin near the soil surface and can extend up to the unifoliate node. Prolonged feeding can cause the stem to break off, resulting in plant death.



**Figure 3.** Gall midge larvae feeding in a soybean stem at the soil surface, South Dakota, August 8, 2018. Photo: Curt Hoffbeck, Pioneer Field Agronomist.



**Figure 4.** Gall midge adults.



**Figure 5.** Galls on a soybean stem due to gall midge infestation (left). Stem girdling from prolonged feeding (right). Photos: Jessie Alt, Corteva Agriscience Research Scientist.



**Figure 6.** Galls on a soybean stem near the soil surface due to gall midge infestation. Nebraska, August 8, 2018. Photo: Jessie Alt, Corteva Agriscience Research Scientist.

## INJURY PATTERNS IN SOYBEANS

Infestation can occur during vegetative and reproductive stages. Injury is generally most severe at field edges (Figures 7 and 8). Injury on field margins suggests fly movement from previous crop residue to new crop. Research has shown that overwintering generation adult emergence comes almost entirely from fields infested the previous year, with very low rates of emergence observed in fencerows and other non-crop areas (McMechan et al., 2021a). Injury has been observed next to CRP, pastures, and tree lines in some cases. In severe cases, infestation can extend into the interior of the field.



**Figure 7.** Dead soybean plants due to gall midge injury along the edge of a soybean field. South Dakota, August 8, 2018; Photo: Curt Hoffbeck, Pioneer Field Agronomist.

Depending on the severity of gall midge infestation, some soybean plants may wilt, die, or simply show signs of poor pod development and small seed size, especially in the upper third of the canopy on “healthy-appearing” green plants. Yield loss varies depending on how early injury occurs and the severity of the infestation in certain areas of a field. Yield losses in soybean gall midge infested fields can be up to 100% within 100 ft from the field edge, with losses of 17%-31% further into the field (McMechan et al., 2021c).

## GALL MIDGE SPECIES

- » The term midge is used to refer to a broad group of small fly species, encompassing several taxonomic families.
- » Gall midge refers to species of flies in the family Cecidomyiidae. Gall midges are characterized by larvae that feed inside plant tissue, resulting in abnormal plant growth (galls).



Hessian fly (*Mayetiola destructor*), an agricultural pest in the *Cecidomyiidae* family. Photo courtesy of Scott Bauer, USDA-ARS.

- » More than 6,000 species of gall midge have been described worldwide, although the total number of species in existence is believed to be much larger. More than 1,100 species have been described in North America.
- » The gall midge family includes numerous species that are economically important pests of agricultural crops, including Hessian fly (*Mayetiola destructor*), wheat blossom midge (*Sitodiplosis mosellana*), and sunflower midge (*Contarinia schulzi*).
- » Some species of gall midge are known to feed primarily on decaying organic matter, fungi, and molds; therefore, they tend to be attracted to damaged or diseased areas on plants.

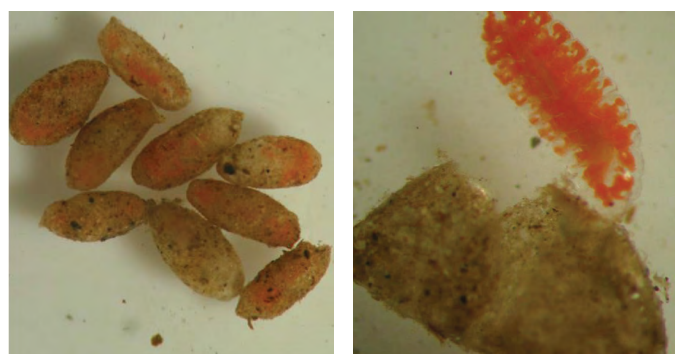


**Figure 8.** Dead soybean plants due to gall midge injury near the edge of a soybean field. Approximately 95% of plants in this area were dead. Iowa, August 3, 2018; Photo: Jessie Alt, Corteva Agriscience Research Scientist.

## SOYBEAN GALL MIDGE LIFECYCLE

Soybean gall midge undergoes complete metamorphosis, with egg, larva, pupa, and adult stages. Gall midge larvae overwinter in larval cocoons in the soil, similar to wheat midge (*Sitodiplosis mosellana*) (Figure 9). The majority of larvae overwinter in the top 1.5 inches of soil. This is relatively shallow compared to species such as northern and western corn rootworm that overwinter as eggs at depths of 4 to 6 inches. Overwintering larvae would have very little protection at such shallow depths from extreme cold temperatures and freeze-thaw cycles. The extent to which winter temperatures and snow cover can influence gall midge populations the following season is not yet known.

"Soybean gall midge undergoes complete metamorphosis, with egg, larva, pupa, and adult stages."



**Figure 9.** Soybean gall midge larval cocoons found in soil samples taken in a field with high soybean gall midge pressure (left). A soybean gall midge larva extracted from a larval cocoon (right). Photos courtesy of Kirk Anderson and Marion Harris, Dept. of Entomology North Dakota State University.

Timing of adult emergence from the soil varies by geography with first adult emergence observed in mid-June in Nebraska and early July in Minnesota (Knodel, 2019). Adults have a long emergence window – overwintering generation adult emergence extended over a 17-day period in a Corteva

Agriscience study in 2019 and as long as 37 days in a 2021 study (Figure 10). Adults live three to five days and do not feed on soybean plants (Calles-Torrez et al., 2020).

Females lay eggs in cracks and fissures in soybean stems. Females do not pierce the stem tissue when laying eggs. Larval infestation of soybean plants has not been observed prior of the V2-V3 growth stage. At this stage of soybean growth, the stem diameter expands creating small fissures allowing the overwintering generation adults to deposit eggs into the stem (McMechan et al., 2021c). Prior to V3, the soybean stems do not have these fissures.



**Figure 10.** Trap set up following soybean planting to measure soybean gall midge adult emergence from the soil in 2019.

Newly hatched larvae feed under the epidermis of the stem and go through three instars. Larvae drop off the plant to the soil, where they form larval cocoons and pupate (Calles-Torrez et al., 2020). Adults then emerge and repeat the cycle. Adults are not strong fliers, so are limited in their mobility. The effect of wind in dispersing adults over longer distances is under investigation.

Based on observations so far, soybean gall midge appears to go through two or three overlapping generations per season. The substantial overlap between generations makes it difficult to detect discrete generations within the growing season, and larvae can be present in an infested field continually over the majority of the growing season. The timing of adult emergence cessation in the fall appears to be relatively consistent from year to year (McMechan et al., 2021a).

Research on soybean gall midge lifecycle has been challenging due to the fact that entomologists have not yet been able to sustain a colony in a laboratory environment. What is known about the insect's lifecycle so far comes



entirely from field observations. Consequently, many aspects of the soybean gall midge lifecycle have been difficult to ascertain or remain unknown. Basic facts such as generation time, number of eggs laid by females, favorable conditions for development, and characteristics that drive host plant selection are all important for formulating a management plan, but remain poorly understood.

Two other host species for soybean gall midge have been identified – alfalfa and sweet clover. There is no apparent need for management in these alternate hosts. Populations observed in alfalfa have been relatively low (McMechan et al., 2021a).



## A SECOND GALL MIDGE SPECIES IN SOYBEAN

In 2019, populations of a second gall midge species were observed in soybeans in Minnesota. These populations were identified as belonging to a different species in the gall midge family (Cecidomyiidae), *Karshomyia caulicola*, known to exist in North America and northern Europe (Koch et al., 2019). Observations of *Karshomyia caulicola* have been in fields infected with white mold and, within the context of soybean management, it is now being referred to as white mold gall midge (WGM). *Karshomyia caulicola* is known to be a fungus feeder on other plant species and appears to only feed on white mold fungus in soybeans and not on the soybean plants. There is no evidence so far of white mold gall midge causing or spreading white mold infection.

Populations of white mold gall midge have been found in soybeans fields in Minnesota, Wisconsin, and North Dakota. White mold gall midge appears to be widespread in the North Central region of the U.S. (Calles-Torrez et al., 2020).

Larvae of white mold gall midge are very similar in appearance to those of soybean gall midge. The most effective way to distinguish between the two species is based on the timing and location of larval feeding. White mold gall midge feeding is specifically associated with the presence of white mold infection, so it has only been observed later in the season after flowering when infected tissue is present. White mold gall midge feeding can occur anywhere in the field where there are infected plants and anywhere on the plant where there is infected tissue.

## MANAGEMENT CONSIDERATIONS

Management practices for gall midge are currently under investigation; however, nothing has worked very well so far. Preliminary investigations into foliar insecticide treatments have shown some promise for suppressing gall midge populations when ap-



*"The long emergence window of soybean gall midge adults poses a significant challenge for timing and effectiveness of insecticide application."*

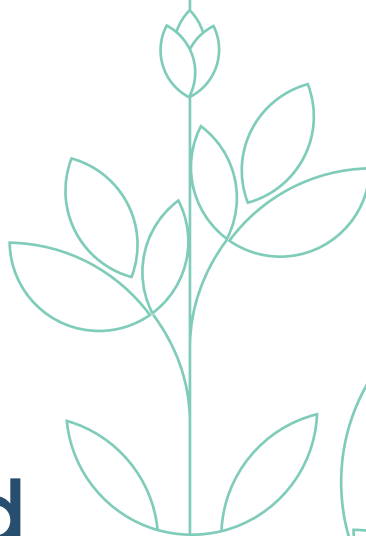
plied at the time of pre- or early post-emergence herbicide applications to control egg-laying adults. However, these types of insecticide applications still need more thorough evaluation, and careful consideration is needed to avoid insect resistance issues with midge or other insects, and potential harm to beneficial insects.

The long emergence window of soybean gall midge adults poses a significant challenge for timing and effectiveness of insecticide application. Foliar treatments later in the season when larval feeding in the stems is already underway are not likely to be effective since the larvae are protected from exposure to the insecticide. More insecticide treatment timings, active ingredients, and rates need to be fully evaluated to determine what options are effective.

In general, the best opportunity for managing soybean gall midge is to limit overwintering generation's ability to infest soybean plants. Tillage of previously infested fields has been investigated as a way to potentially reduce adult emergence by disturbing the larval cocoons in the soil. Spring tillage has shown some effectiveness in reducing emergence rates and also appears to shift emergence earlier, possibly due to the quicker warming of the soil (McMechan et al., 2021b). Ridging soil around the stems of soybean plants has also been investigated as a way to impede egg laying in stem fissures. This technique has shown some effectiveness but is not likely to be a practical management tactic for many growers. Planting fields with a history of soybean gall midge last may provide some benefit, as early-planted soybeans tend to attract more overwintering generation adults.

Research on differences in soybean variety susceptibility to gall midge damage is ongoing. Host plant resistance is used to manage midges in other crops, so may offer some promise in soybeans. The goal is to identify a characteristic that makes soybeans less attractive or more resistant to egg-laying midges (Sever, 2021).

"White mold is a monocyclic disease, which means that it goes through one development cycle per crop cycle."



# White Mold Management in Soybeans

Mark Jeschke, Ph.D., Agronomy Manager

- White mold (*Sclerotinia sclerotiorum*) is a fungal disease of soybean that has become a more frequent issue over the past 30 years in the Northern U.S. and Canada.
- White mold is a disease of high yield potential soybeans – the better the establishment and growth of the crop, the greater the risk of white mold.
- White mold is favored by cool and wet weather and dense soybean canopies that help retain these conditions under the crop canopy.
- Integrating several cultural practices is the most effective means of managing white mold. Cultural practices include variety selection, crop rotation, weed management, no-till, and if necessary, limiting dense canopy formation.
- Several fungicides are labeled for white mold but must be applied before the appearance of symptoms and generally will not provide complete control.
- Foliar chemical applications should be targeted at early flowering (R1); penetration of spray to the lower soybean canopy is necessary for treatments to be effective.

## A GROWING PROBLEM IN SOYBEANS

White mold (*Sclerotinia sclerotiorum*) is a fungal disease that can attack hundreds of plant species. Also known as Sclerotinia stem rot, white mold was first observed on soybeans in central Illinois in 1948 and for many years was only a sporadic soybean disease in Minnesota, Wisconsin, and Michigan. However, since the 1990s it has become a more frequent threat to northern states from Minnesota to New York., as well as the northern areas of states bordering to the south.

The reason for the abrupt increase in the frequency and severity of white mold infection is not fully understood. Changes in soybean management practices likely have played a role. Practices such as earlier planting, longer maturity varieties, and narrow row spacing that have been important in driving higher soybean yields also tend to create a more favorable environment for white mold disease development by accelerating canopy closure during the season. Changes in genetic resistance of commercial soybean varieties, as well as changes in the pathogen itself may also be factors.



**Figure 1.** White fungal mycelia visible on the stem of a soybean plant infected with white mold.

A successful management plan for white mold in soybean needs to take factors such as variety selection and agronomic management into account, in addition to any chemical control treatments.

## LIFE CYCLE AND SYMPTOMS

White mold is a monocyclic disease, which means that it goes through one development cycle per crop cycle. White mold persists in soybean fields over time by survival structures called sclerotia. These dark, irregularly shaped bodies about ¼ to ½ inch long are formed within the white, cottony growth both inside and outside the stem. Sclerotia contain energy reserves and function much like seeds, surviving for years in the soil and eventually germinating, producing millions of spores beneath the plant canopy.



**Figure 2.** Mushroom-like apothecia forming on sclerotia.  
Image courtesy of the Plant Disease Clinic, Ext. Plant Pathology, Univ. of MN.

In the most common form of germination, a sclerotium produces one or more germ tubes or stipes that grow upward from a depth of two inches or less in the soil. When it reaches the soil surface, the germ tube is triggered by light to produce a small, flesh-colored structure much like a mushroom, called an apothecium. One sclerotium can produce numerous apothecia simultaneously or sequentially throughout the growing season. Each apothecium produces millions of spores beneath the plant canopy, which are periodically released and spread to the plants.



**Figure 3.** Senescing flowers are the entry point for the white mold pathogen to infect the plant.

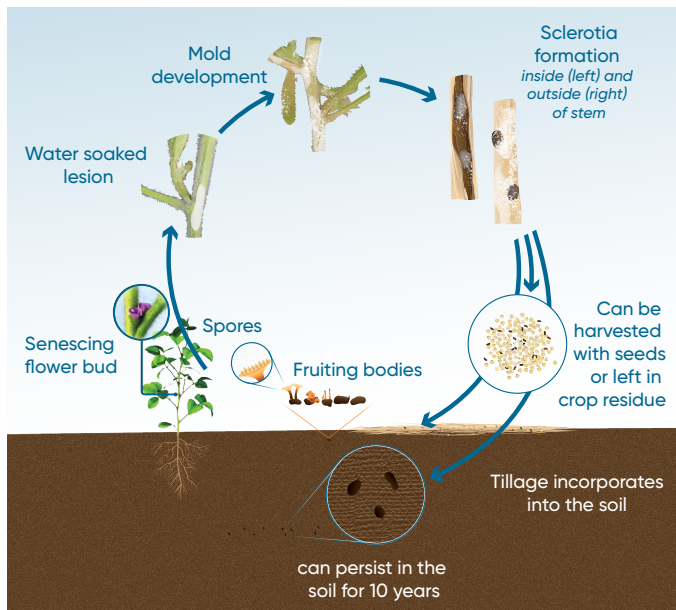
White mold spores are not able to invade plants directly but must colonize dead plant tissue before moving into the plant. Senescing flowers provide a ready source of dead tissue for colonization. Flowers start senescing as soon as they open. From these senescing flowers in the branch axils or stuck to developing pods, the fungus spreads to healthy tissue.

It takes around 2 to 3 weeks from initial infection for the fungus to colonize the plant and erupt. The first symptom of white mold infection appears as a water-soaked stem lesion originating from a node. If the lesion remains wet, it becomes overgrown with white mold. The disease can then spread directly from plant to plant by contact with this moldy tissue. Sclerotia are formed within the moldy growth and inside the stem to complete the disease cycle. The shape of the sclerotia can vary based on where they form. Those that form outside the plant will be more spherical, while those that form inside the plant stem will be more oblong.

Plant damage is incurred as tissue rot and formation of sclerotia inside the stem result in rapid wilting and death of the upper part of the plant. As the disease progresses, premature death of the entire plant can occur.



**Figure 4.** White mold sclerotia on soybean stem.



**Figure 5.** White mold disease cycle.

## FAVORABLE CONDITIONS

Wet, cool conditions are required throughout the white mold disease cycle, including germination of the sclerotia in the soil, spore release, infection of soybean flowers by spores, and spread of white mold from plant to plant.

- Sclerotia in the soil require seven to 14 days of high soil moisture to germinate and produce apothecia (fruiting bodies). Temperatures between 40° F and 60° F are optimal for this process.
- Spores are forcibly ejected from the fruiting bodies during wet weather conditions.
- After spores are released, a wet surface on senescing flowers or other dead or dying tissue is required for spore germination. Specifically, two to three days of continuous wetness, or more than 12 hours of daily wetness for three to five days is required.
- White mycelial growth develops on stem lesions that remain wet, and spreads by contact to neighboring plants. Temperatures under 85° F are favorable for disease spread.



**Figure 6.** White mold on soybean stems.

Early establishment of a dense soybean canopy increases the likelihood that the high-humidity conditions required for white mold development will occur. Early canopy closure is a goal for many soybean producers, especially in northern locations and growing environments where solar radiation may be limited, as it is important for maximizing light interception and yield. Soybean management practices such as early planting and narrow rows can help achieve earlier canopy closure. Unfortunately, these practices can also encourage white mold development.

## RISK FACTORS FOR WHITE MOLD

The North Central Plant Health Initiative has developed the following list of risk factors for white mold.

### Seasonal Risk Factors for White Mold Development

**Weather:** Moderate temperatures (<85° F), normal or above normal precipitation, soil moisture at field capacity or above, and prolonged morning fog and leaf wetness (high canopy humidity) at and following flowering into early pod development.

**Early canopy closure** due to early planting, high plant population, narrow rows, excessive plant nutrition and optimal climatic conditions creates dense canopy and increased apothecia density.

**History of white mold** in the field, density of the white mold pathogen, apothecia present on soil surface at flowering, distribution of pathogen/disease in field.

**Soybean variety planted.** Plant structure and physiological functions govern variety reaction to white mold. Varieties range from partially resistant to highly susceptible.

### Long-Term Risk Factors for White Mold Development

**Field/cropping history.** Pathogen level will gradually increase if:

- Other host crops are grown in rotation with soybean.
- Only 1- to 2-year intervals occur between soybean crops.
- White mold susceptible varieties are grown.

**Weed management systems.** Inoculum will increase if control of broadleaf weeds is ineffective. Some herbicides used in rotation systems may be suppressive to white mold.

**Topography of field.** Pockets of poor air drainage, tree lines and other natural barriers that impede air movement will create a favorable micro-environment for white mold development.

#### Pathogen introduction:

- Contaminated and infected seed.
- Movement of infested soil with equipment.
- Wind-borne spores from apothecia from area outside fields.

## MANAGEMENT OF WHITE MOLD

White mold is a disease of high yield potential soybeans. Often, the better the establishment and growth of the crop, the more likely it will be damaged by white mold. Management practices that may be useful for reducing the severity of white mold infection may also limit the yield potential of the crop; consequently, an integrated management strategy for white mold often involves weighing the tradeoffs between pushing for maximum yield vs. protecting against disease based on the white mold risk in a given field.

No single practice will be effective in completely controlling white mold, but several options are available to help reduce disease pressure. Current options include disease avoidance, variety selection, changes in cropping systems including tillage and rotation, and adjusting production methods such as planting practices, chemical applications and weed control.



**Figure 7.** Infected soybean stem.

### Disease Avoidance

White mold spreads either by movement of spores or sclerotia from field to field. Spores are airborne and may originate from any field that has had white mold in the past. However, spores generally do not move long distances, as they originate near the soil surface and commonly stay contained below the crop canopy. Spread over longer distances is usually due to movement of sclerotia.

Sclerotia move from field to field in harvest equipment or in contaminated seed. Harvest equipment should be thoroughly cleaned when moving from infected to non-infected fields. Harvesting infected fields last provides additional safety. Because sclerotia are roughly the size of soybean seed, they can't be easily separated by the combine. Soybeans harvested from infected fields are most likely loaded with sclerotia. Planting these soybeans would place them at the ideal depth for germination and infection of that crop and field. Growers should absolutely not save seed from infected fields.

Corteva Agriscience avoids growing seed beans in fields with a history of white mold. In addition, seed is thoroughly cleaned and inspected to ensure that it is disease-free. Seed cleaning with a gravity table or centrifugal tower is essential to remove sclerotia. Fungicide seed treatments can help ensure that no disease is transmitted by mycelia present on seed.

### Variety Selection

There is no absolute resistance available to white mold (all varieties can get the disease under severe pressure), but differences in tolerance exist between varieties. Pioneer variety ratings range from 2 to 7 on a scale of 1 to 9 (9 = resistant). Ratings reflect varietal differences in the rate at

which infection develops as well as the extent of damage it causes and are based on data from multiple locations and years. Choosing varieties that rate high for tolerance is an important management practice in areas that commonly encounter white mold. Your local Pioneer sales professional can suggest white mold tolerant varieties with a complete package of traits needed for top soybean production in your area.

Variety maturity is also an important consideration. Longer maturity varieties can help maximize yield potential, but they also have a longer window of flowering, which extends the period of time that senescing flowers are present and susceptible to infection.

### No-Till

Research studies have shown that no-till is generally superior to other tillage systems in limiting white mold development by leaving sclerotia to deteriorate on the soil surface. Sclerotia germinate from the top two inches of soil. Below that depth, they can remain dormant for five or more years. Because of its longevity in the soil, it is difficult to devise a strategy to control white mold with tillage. Deep tillage buries sclerotia from the soil surface but may also bring prior sclerotia into their zone of germination.

### Crop Rotation

Rotation with a non-host crop can help reduce disease pressure in a field. Non-host crops include corn, sorghum, and small grains. Susceptible crops to avoid in a rotation include alfalfa, clover, sunflower, canola, edible beans, potato, and others. Depending on soybean tolerance, field history and other factors, more than one year away from soybeans may be required. Including a small grain crop in the rotation can be particularly helpful, as the canopy is dense enough to trigger formation of apothecia from the sclerotia in the soil but there is no host crop to infect. However, because of the longevity of sclerotia in the soil, crop rotation is only a partial solution.

### Planting Date

Later planted soybeans are generally shorter and less branched and therefore later to reach canopy closure. Some planting date studies show that later planting results in less incidence of white mold. However, yields are generally reduced when planting is delayed past mid-May in northern states. The tradeoff between less yield reduction due to white mold but more yield reduction due to late planting may not be favorable, especially in years of low disease pressure.

### Row Spacing and Seeding Rate

Row spacing and seeding rate both influence soybean canopy closure and density, which affect development of white mold. However, given that early canopy closure is generally favorable to yield, adopting wider row spacings or lower seeding rates to manage white mold may also reduce yield potential.

The most common row spacings for soybeans in the U.S. are 15 inches and 30 inches. Drilled soybeans in row spacings less than 15 inches were once common but have declined in recent years. Numerous studies over many years have demonstrated

a yield advantage for narrow-row (<30 inches) soybeans. A Pioneer review of several university trials found an average yield benefit of around 4 bu/acre for drilled or 15-inch row soybeans compared to 30-inch rows (Jeschke and Lutt, 2016).

Research has shown that seeding rate is likely a more important factor affecting white mold development than row spacing (Lee et al., 2005). In fields with high risk of white mold, seeding rates should be sufficient for uniform stand establishment, but shouldn't be aggressively high. Actual rates will vary depending on planting date, seedbed conditions, and seed quality. A multi-state university study found that wider rows and reduced seeding rates were both effective at reducing white mold severity, but also reduced soybean yield when white mold did not develop (Webster et al., 2022). Results suggested that wider rows and reduced seeding rates as tactics to manage white mold should be reserved for fields with a history of white mold where disease is likely to occur.

### Weed Control

White mold has over 400 plant hosts, including many broadleaf weeds. Host weeds that are also common weed species throughout soybean growing areas include lambsquarters, ragweed, pigweed, and velvetleaf. In addition to acting as host to the disease, weeds can also increase canopy density, which favors disease development.

## CHEMICAL TREATMENTS FOR WHITE MOLD

Despite the best use of cultural practices to limit the incidence of white mold, weather and other conditions conducive to disease development may still cause heavy infestations. In cases of high disease risk, a foliar application of a chemical product or a soil application of a biological product may help reduce disease severity and protect soybean yield.

Products labeled for white mold control or suppression include several foliar fungicides (Table 1), a biological fungicide (Contans® fungicide), and the herbicide lactofen (active ingredient in Cobra® herbicide and Phoenix® herbicide).

**Table 1.** Fungicides labeled for control of white mold in soybeans with an efficacy of "fair" or better (Wise, 2023).

Fungicide Trade Name	Active Ingredient	White Mold Efficacy
Approach® 2.08 SC	picoxystrobin	good
Topguard® 1.04 SC	flutriafol	fair
Proline® 480 SC	prothioconazole	fair
Domark® 230 ME	tetraconazole	fair
Topsin-M®	thiophanate-methyl	fair
Omega® 500 DF	fluazinam	good
Endura® 0.7 DF	boscalid	very good
Propulse® 3.34 SC	fluopyram, prothioconazole	good
Delaro® 325 SC	trifloxystrobin, prothioconazole	fair

White mold efficacy is based on R1-R2 application timing, and lower efficacy is obtained at R3 or later application timings, or if disease symptoms are already present at the time of application.

Chemical treatments generally will not provide complete control of white mold. Reduction of disease in university field trials has ranged from 0% to 60% (Mueller et al., 2015). Consequently, chemical treatments need to be used as part of an integrated management strategy for white mold.

### Foliar Fungicides

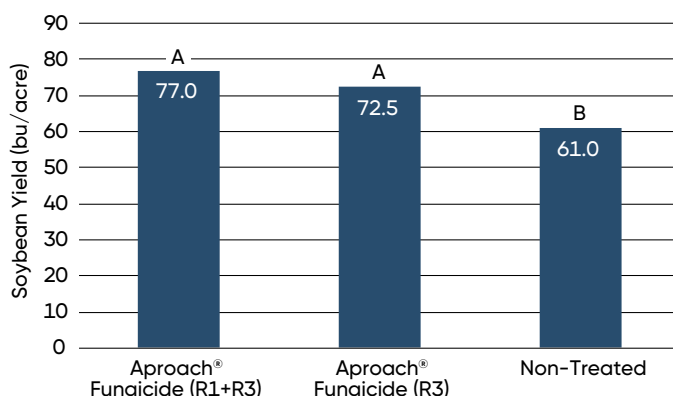
Optimum application time of fungicides for white mold control in soybeans is the R1 to R2 growth stage, also known as the beginning bloom or first flower stage (Mueller et al., 2015). For much of the U.S. Corn Belt, the R1 stage coincides with the first two weeks of July when the vegetative growth stage is typically about V7 to V10 (Pedersen, 2009). Fungicides applied up to the R3 stage can provide some benefit in reducing white mold.

Fungicides have little activity on established disease and must be applied prior to white mold invasion of senescing flowers. Applications made just prior to pathogen invasion have helped reduce disease severity in some studies. Because soybeans normally flower for 30 days or more (R1 to R5) and fungicides for white mold control have maximum residual activity of about two weeks, a second application may be necessary if conducive environmental conditions persist into mid-summer.

One drawback to later (R3) fungicide application is the potential for reduced canopy penetration. Though soybeans grown in 30-inch rows at moderate seeding rates may allow for good penetration of the lower canopy at R1, spray coverage of the lower nodes becomes increasingly difficult with continued vegetative growth. As depicted in Figure 5, the lower canopy can remain relatively wet or humid, providing the appropriate environment for pathogenicity. Thus, it is essential for spray droplets to reach the lower two-thirds of the soybean canopy in order to obtain satisfactory disease control.

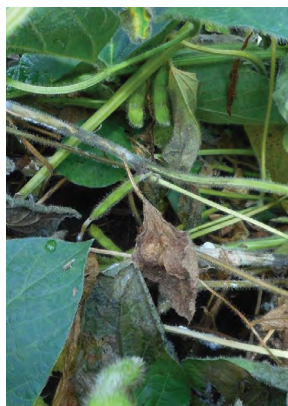
### Fungicide Research Results

A University of Wisconsin research trial conducted near Hancock, WI, in 2016 found significant increases in soybean yield associated with Aproach® fungicide treatment under high levels of white mold pressure (Figure 8). A single treatment at the R3 growth stage increased yield by 11.5 bu/acre and sequential applications at the R1 and R3 stages increased yield 16 bu/acre compared to the non-treated check.



**Figure 8.** Yield of soybeans treated with Aproach® fungicide at the R3 growth stage and the R1 and R3 stages compared to non-treated soybeans in a Univ. of Wisconsin trial at Hancock, WI, in 2016 (Smith et al., 2016).

Means labeled with the same letter are not significantly different based on Fisher's Least Significant Difference (LSD;  $\alpha=0.05$ )

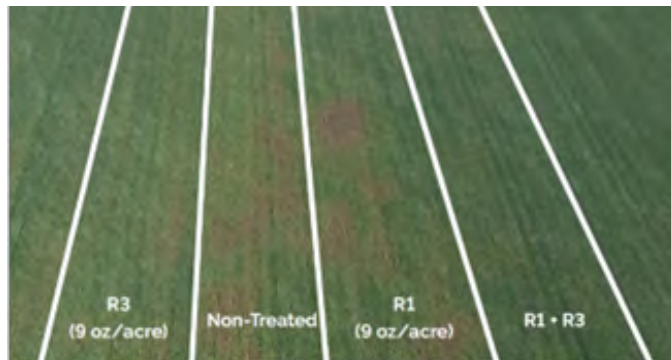


**Figure 9.** Soybean plants infected with white mold.

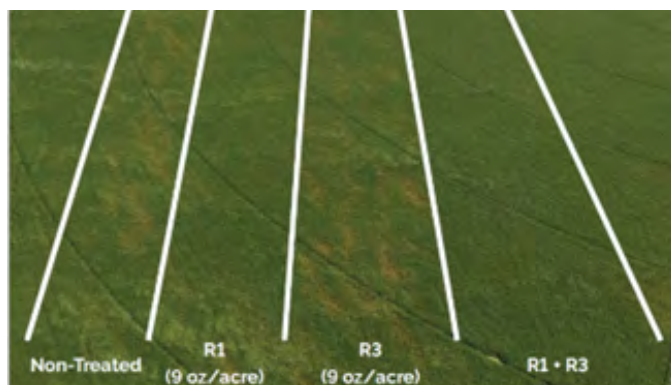
Corteva Agriscience on-farm research trials were conducted in 2017 at locations near Orchard, NE, and Edgar, WI, that experienced high white mold pressure. Both trials compared sequential applications at the R1 and R3 growth stages and single-pass treatments at both R1 and R3 to a non-treated check. The Wisconsin trial was non-replicated, and the Nebraska trial included two replications. The two-pass fungicide program increased yield by an average of 13.3 bu/acre in these trials (Table 2). The R3 and R1 treatments increased yield by an average of 8.7 and 6.7 bu/acre.

**Table 2.** Soybean yield associated with Aproach® fungicide treatments in on-farm trials with heavy white mold pressure in Wisconsin and Nebraska.

Fungicide Treatment	Edgar WI	Orchard NE	Average	Yield Advantage
————— bu/acre —————				
Aproach® (R1+R3)	66.6	55.9	61.3	<b>+13.3</b>
Aproach® (R3)	57.7	55.6	56.7	<b>+8.7</b>
Aproach® (R1)	61.9	47.4	54.7	<b>+6.7</b>
Non-Treated	54.8	41.2	48.0	



**Figure 10.** Corteva Agriscience on-farm fungicide research trial near Edgar, WI comparing Aproach® fungicide applied at R1, R3, and R1+R3 growth stages to a non-treated check under heavy white mold pressure (September 11, 2017).



**Figure 11.** Corteva Agriscience on-farm fungicide research trial near Orchard, NE comparing Aproach® fungicide applied at R1, R3, and R1+R3 growth stages to a non-treated check under heavy white mold pressure (August 23, 2017).

**Cobra® Herbicide**

Lactofen, the active ingredient in Cobra herbicide, and Phoenix® herbicide is for post-emergence weed control in soybeans. In addition, it is a potent elicitor of the phytoalexin glyceolin (Nelson et al., 2001). Phytoalexins are antimicrobial substances produced by plants in response to invasion by certain pathogens or by chemical or mechanical injury (Agrios, 1988).

Studies have shown that the optimum application time for Cobra herbicide is at R1, which is identical to timing recommendations for foliar fungicides. Although small yield improvements were observed with V4 to V5 Cobra herbicide treatments, yield increases were larger and more consistent with applications at R1 (Figure 6). Despite heavy disease pressure (48% incidence), Cobra herbicide has been shown to reduce disease incidence and increase yield of susceptible soybean varieties (Oplinger et al., 1999). However, a moderately resistant variety showed no response to Cobra herbicide and produced a higher yield than a treated susceptible variety. Due in part to unpredictable disease levels and variations in varietal tolerance to white mold, yield increases with Cobra herbicide have tended to be highly variable (Nelson et al., 2002).

Herbicides with PPO inhibiting sites of action, such as Cobra, herbicide usually cause moderate levels of leaf necrosis.

Although the reduction in leaf area from this necrosis is likely a contributing factor in white mold control with Cobra herbicide, yield loss may result in the absence of disease (Dann et al., 1999; Kyle, 2014). Producers should use caution when considering the widespread use of Cobra herbicide, especially on moderately resistant varieties when environmental conditions do not favor disease.

Contans® WG fungicide: Contans fungicide is a biological control agent of white mold. The product contains the soil fungus *Coniothyrium minitans*, which acts as a parasite attacking the overwintering survival structures (sclerotia) of white mold. Contans fungicide is applied to the soil, its spores germinate with sufficient moisture, and the fungus can destroy sclerotia if given adequate time. According to the manufacturer, Contans fungicide should be applied at least three months prior to white mold infection, and soil-incorporated immediately following application to a depth of at least 4 inches. Contans fungicide has been evaluated in both greenhouse and field studies (Hao et al., 2010). In both cases, efficacy has been good, as reduced apothecia number and improved soybean yield have been observed. Although Contans fungicide may be fall- or spring-applied, fall applications have performed better than those done in spring.

# Red Crown Rot in Soybeans

Mark Jeschke, Ph.D., Agronomy Manager

## KEY FINDINGS

- → Red crown rot is a fungal disease of soybeans that has been common in the southern U.S. for years but is now spreading in the Midwest.
- → Red crown rot causes deterioration of the stem and roots, as well as premature senescence and can result in significant reductions in yield.
- → Later planting in infested fields, improved soil drainage, and management of root-feeding insects and nematodes can help reduce the impact of red crown rot.

## NEW TO THE MIDWEST, BUT NOT NEW

- Red crown rot is a fungal disease of soybeans caused by the soilborne pathogen *Calonectria ilicicola* (anamorph: *Cylindrocladium parasiticum*) and characterized by fungal structures on the stem and root that give it a reddish appearance (Figure 1).
- Red crown rot is a new disease of soybeans in the Midwestern U.S., having first been detected in Pike County, Illinois, in 2017 (Kleczewski, 2020).
- In the years since its initial detection, red crown rot has spread through central Illinois and into Kentucky (Bradley, 2021).
- *C. ilicicola* was first identified in 1950 and has been a pathogen of soybeans in the southern U.S. since the 1970s and in Japan since the 1960s.
- *C. ilicicola* has a broad host range and is a disease in several other crops, including peanut, ginger, and blueberry. Red crown rot is common in areas of the south and southeast where soybeans are grown in rotation with peanuts.



**Figure 1.** The key identifying characteristic of red crown rot in soybean is the presence of tiny red balls on the crown and stem near the soil line.



**Figure 2.** Foliar symptoms of red crown rot – interveinal chlorosis and necrosis – are indistinguishable from those caused by SDS, so inspection of the stem and crown is necessary to determine the causal pathogen.

## INFECTION AND SPREAD IN SOYBEANS

- *C. ilicicola* is soilborne and causes deterioration of the root and stem in soybeans.
- Infection is favored by wet conditions following planting and will often show up in low-lying and poorly drained areas of a field.
- Disease progression is favored by warm, wet conditions during the growing season.
- Warm soil temperatures between approximately 77° F and 86° F favor disease development, with infection decreasing when soil temperatures exceed 86° F.
- Secondary spread during the growing season can be caused by the ejection of mature ascospores from the perithecia on the stem, which are distributed by splashing and runoff from rainfall.
- Later in the season, the fungus can produce a toxin that accumulates in the leaves, causing interveinal chlorosis followed by necrosis (Figure 2).





**Figure 3.** Soybean plant with senesced leaves caused by red crown rot infection.

- Severely affected plants will senesce prematurely, with the leaves staying attached to the plant (Figure 3).
- *C. illicicola* overwinters in soils as microsclerotia, which can survive for several years without the presence of a host crop.
- Microsclerotia are spread by the movement of plant debris and infested soil particles, which can be carried by wind or transported between fields by equipment or livestock.

## SYMPTOMS AND IDENTIFICATION

- Red crown rot infection is often detected after the R3 stage with the appearance of yellowing on the leaves, although root and stem rot can occur without producing foliar symptoms.
- Foliar symptoms can be very similar to those of other common soybean diseases, such as sudden death syndrome, brown stem rot, and southern stem canker, so inspection of the stems and roots is necessary to determine the causal pathogen.
- Foliar symptoms typically do not appear uniformly across a field, often showing up as single plants or small patches of infected plants randomly throughout the field.
- The key distinguishing characteristic of red crown rot is the presence of perithecia on the crown and roots just below the soil line, which look like tiny red balls and will give the crown a reddish coloration.

- Under wet conditions, the perithecia can extend above the soil line on the lower stem.
- Other factors can cause a reddish coloration of the lower stem, so it is important to look closely to confirm the presence of fungal tissues.
- White fungal hyphae can also appear on infected tissue.
- The pith in the crown of an infected plant may have a gray discoloration.
- Plants with severely rotted roots can be easily pulled from the soil. Diseased plants may have more than one pathogen present.

## MANAGEMENT CONSIDERATIONS

- Yield losses of 25% to 30% have been documented for red crown rot infections in soybeans in Louisiana and Mississippi, where the disease has been present for years.
- Severely infected areas can be significantly impacted; however, red crown rot usually only affects patches within a field.
- Management options for red crown rot are limited and no rescue treatments are available to mitigate plant damage and yield impact once infection has been detected.
- Delaying soybean planting in fields known to be infested with *C. illicicola* can help reduce the severity of infection.
- Management of pathogenic nematodes can help reduce the severity of red crown rot. Nematode damage to the roots can create access points for infection by soilborne pathogens.
- Crop rotation into a non-host crop can help reduce inoculum load in the soil.



**Figure 4.** Perithecia on a soybean plant with red crown rot.

# Soybean Vein Necrosis Virus

Mark Jeschke, Ph.D., Agronomy Manager

## KEY POINTS:

- Soybean vein necrosis is the most widespread viral disease of soybeans in the United States.
- Soybean vein necrosis virus is primarily transmitted by soybean thrips, which pick up the virus by feeding on infected plants and then spread the virus to other plants.
- Neither thrip feeding nor plant disease associated with soybean vein necrosis virus typically cause economic levels of damage in soybeans.

## VIRAL DISEASE OF SOYBEANS

- Soybean vein necrosis virus is a viral pathogen first identified in soybeans in Arkansas and Tennessee in 2008 (Tzanetakis et al., 2009).
- The relatively low genetic diversity of the virus and inefficiency of its spread in soybean suggest that it originated in a different host species and was introduced to soybean relatively recently (Zhou and Tzanetakis, 2013; 2019).
- Since its discovery, soybean vein necrosis virus has been reported throughout the major soybean-producing areas of the U.S. and Canada (Zhou et al., 2011).

## DISEASE HOSTS AND TRANSMISSION

- Viruses are obligate pathogens that must always pass from living host to living host.
- Viral diseases in crops are typically spread via an insect vector that picks up the virus by feeding on an infected plant, then spreads the virus to other plants.
- Soybean vein necrosis virus belongs to the genus *Orthospovirus*, a group of plant viruses transmitted by thrips.
- Soybean vein necrosis virus is primarily transmitted by soybean thrips (*Neohydatothrips variabilis*), but may also be spread by eastern flower thrips (*Frankliniella tritici*) and tobacco thrips (*F. fusca*) (Zhou and Tzanetakis, 2013; Keough et al., 2016).
- Several alternate host species have been identified, some of which can host the virus without displaying any symptoms of disease (Table 1).
- Kudzu may be the most important host species for soybean vein necrosis virus. It is a perennial weed prevalent throughout the Southeastern U.S. that could serve as a major reservoir for the virus and an early-season habitat for thrips (Zhou and Tzanetakis, 2019).



**Figure 1.** Symptoms of soybean vein necrosis virus begin as light green to yellow (chlorotic) patches near main leaf veins, which can enlarge and eventually become necrotic.

**Table 1.** Known host species for soybean vein necrosis virus (Zhou and Tzanetakis, 2013; 2019).

Common Name	Scientific Name
Pigeon pea	<i>Cajanus cajan</i>
Muskmelon	<i>Cucumis melo</i>
Field pumpkin	<i>Cucurbita pepo</i>
Chrysanthemum	<i>Dendranthema grandiflorum</i>
Buckwheat	<i>Fagopyrum esculentum</i>
Soybean	<i>Glycine max</i>
Ivy-leaved morning glory	<i>Ipomoea hederacea</i>
Entireleaf morning glory	<i>I. hederacea</i> var. <i>integriuscula</i>
Pitted morning glory	<i>I. lacunose</i>
Medicago	<i>Medicago truncatula</i>
Kudzu	<i>Pueraria montana</i>
Benth	<i>Nicotiana benthamiana</i>
Tobacco	<i>N. tabacum</i> , <i>N. glutinosa</i>
Mung bean	<i>Vigna radiata</i>
Cowpea	<i>V. unguiculate</i>

## SOYBEAN THRIPS

- Soybean thrips (*Neohydatothrips variabilis*) are a very common insect pest of soybeans.
- Thrips have rasping and piercing mouthparts that they use to puncture plant cells and feed on the contents.
- They usually feed along the veins on the undersides of leaves, leaving tiny, pale-colored scars.



Soybean thrip (Image credit: Adam Sisson, Iowa State University, Bugwood.org)

- Populations go through multiple overlapping generations each year and adults are present throughout the growing season.
- Thrips can cause visible damage to soybeans, particularly when heavy feeding occurs early in the growing season, but they are not generally considered an economic pest of soybean.
- Higher levels of thrip damage can occur with hot and dry conditions.

## SYMPTOMS AND CROP IMPACT

- Soybean vein necrosis virus causes localized infection in soybean. The virus is restricted to the area around the point of infection and is not systemic in the plant.
- Early symptoms are light green to yellow (chlorotic) patches near main leaf veins, where thrips feed (Figure 2).
- Chlorosis progresses to necrotic (dead) tissue, which may eventually lead to leaf death (Figure 3). Browning of veins may be noticeable on the undersides of leaves.
- Vein necrosis symptoms are more common during hot, dry summers when thrip activity is increased.
- Soybean vein necrosis virus typically does not cause significant yield loss but may reduce seed oil content (Anderson et al., 2017).
- Soybean varieties may differ in their susceptibility to soybean vein necrosis virus.
- Research indicates it is unlikely that soybean vein necrosis virus is transmitted via seed (Zhou and Tzanetakis, 2019).



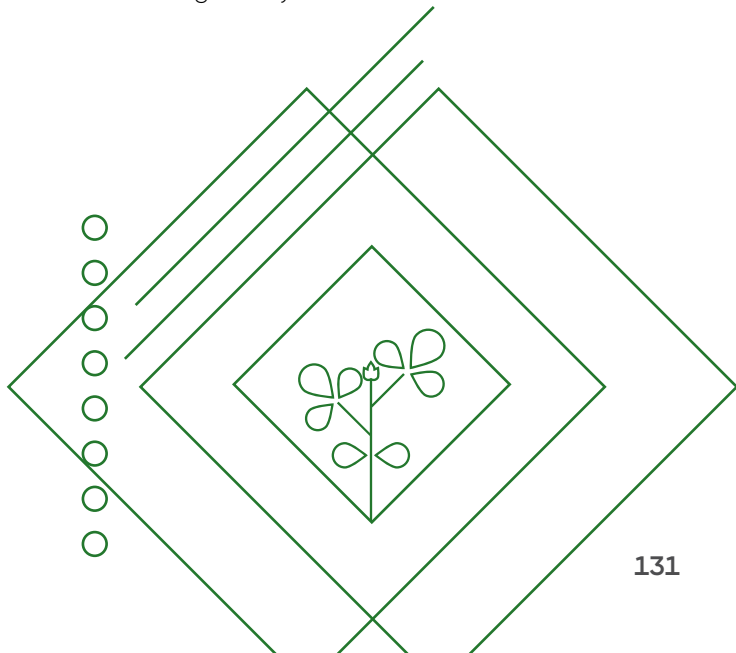
**Figure 2.** Early symptoms of soybean vein necrosis virus are light green to yellow (chlorotic) patches near main leaf veins, where thrips fed.



**Figure 3.** Later symptoms of soybean vein necrosis virus. Infected patches on the leaves have turned necrotic.

## MANAGEMENT

- No management recommendations currently exist.
- Management practices for similar viral diseases have generally focused on host plant resistance and managing vector populations.
- Neither thrip feeding nor plant disease caused by soybean vein necrosis virus typically cause economic levels of damage in soybeans.



# Soybean Cyst Nematode Populations Across Northern Iowa

Bill Long, Troy Deutmeyer, Nate LeVan, and Alex Woodall, Field Agronomists; Nate Pech, Field Sales Agronomist; Jake Bates, Product Agronomist; Cale Gent, Sales Consultant; Nick Hanson, Associate Seller; and Chris Phipps, Territory Manager

## KEY FINDINGS

- → More than 93% of fields sampled had soybean cyst nematode (SCN) population levels capable of causing some level of crop damage (10% or greater yield loss potential).
- → SCN egg counts were 61% lower on average in areas of the sampling locations planted to varieties with Peking SCN resistance compared to areas planted with PI88788 varieties.
- → Soybean growers can reduce the risk of SCN damage by planting resistant varieties, rotating between PI 88788 and Peking resistance sources, and using a nematode protectant seed treatment such as ILEVO® HL.

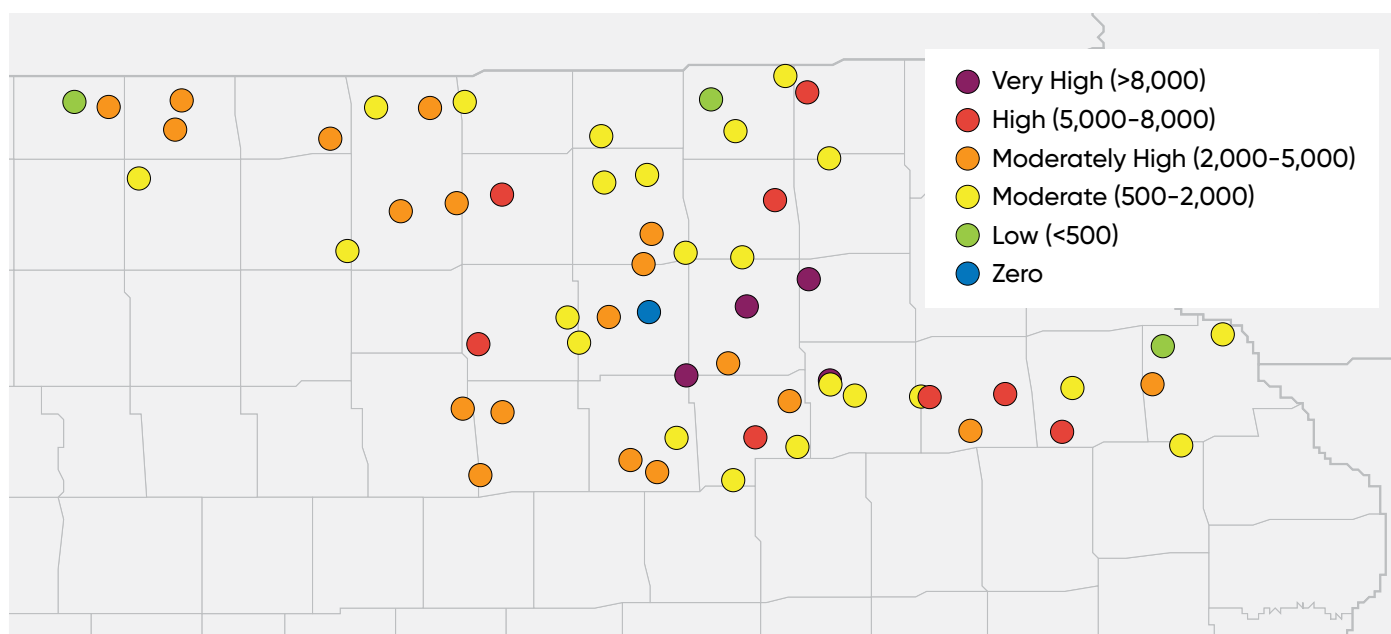
## OBJECTIVES AND STUDY DESCRIPTION

- Soybean cyst nematode (SCN) samples were collected from 61 soybean fields in northern Iowa to determine SCN population levels and potential for soybean yield loss (Figure 1).
- Sample locations included varieties with PI88788 and Peking SCN resistance sources planted in the same field. SCN samples were collected from both.

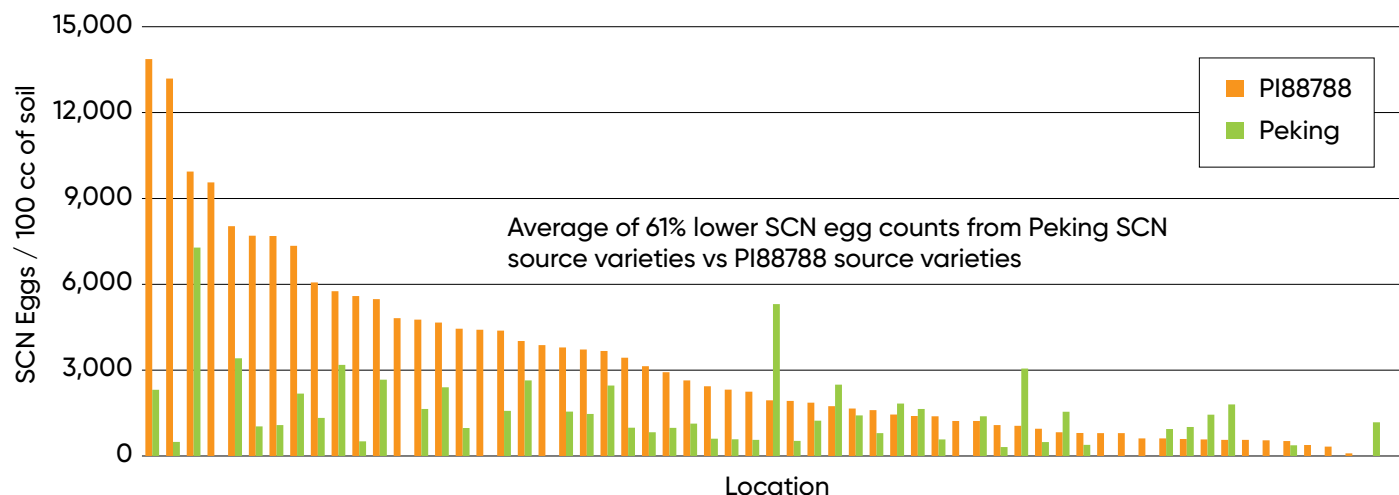
- Fields were sampled at the end of the growing season following harvest.
- Sample cores were taken to a depth of approximately six inches. Subsamples from across the PI88788 or Peking variety areas were blended into composite soil samples and submitted to Ever-Green Nematode Testing Labs for analysis.

## RESULTS

- SCN infestations were found throughout the study area, with more than 93% of fields sampled having some level of SCN infestation that could lead to yield losses greater than or equal to 10% (Table 1).
- 54% of fields sampled had SCN population levels capable of causing moderately high to severe crop damage (>20% yield loss) (Table 1).
- SCN egg counts were 61% lower on average in areas of the sampling locations planted to varieties with Peking SCN resistance compared to areas planted with PI88788 varieties (Figure 2).
- 48 of the 61 sample fields (79%) had lower SCN egg counts in the areas planted to varieties with Peking SCN resistance compared to areas planted with PI88788 varieties (Figure 2).



**Figure 1.** SCN sampling locations and population levels across northern Iowa in 2023.



**Figure 2.** SCN egg counts from areas planted to Peking or PI88788 soybean varieties at 61 northern Iowa sampling locations in 2023.

**Table 1.** SCN population classifications, population levels of 2023 study locations, and potential soybean yield loss.

SCN Population (eggs/100 cc of soil)	Percent of Sample Locations in 2023	Potential Yield Loss with no Management*
Zero	1.6	–
Low (<500 eggs)	4.9	Unlikely
Moderate (500–2,000)	39.3	~10%
Mod-High (2,000–5,000)	32.8	~20%
High (5,000–8,000)	13.1	~50%
Very High (>8,000)	8.2	Very High

\* SCN population classifications and yield loss estimates per analysis reports provided by Ever-Green Nematode Testing Labs. Actual yield loss will depend on multiple factors.

## SCN MANAGEMENT

### Decreased Efficacy of PI88788 Resistance

- Beginning in the 1990s, the widespread availability of soybean varieties with PI88788 SCN resistance provided a largely effective management tool for SCN in North America.
- In recent years however, PI88788 has been losing its effectiveness as a SCN management tool.
- Levels of reproduction on PI88788 among Iowa SCN populations have increased steadily over the last two decades. These results show that Iowa SCN populations are adapting to PI88788 resistance and the resistance is considerably less effective now compared to when it was introduced in the early 1990s (Tylka, 2022).

### Management Recommendations

- The SCN Coalition provides the following recommendations for developing a plan to manage SCN ([www.thescncoalition.com](http://www.thescncoalition.com)):
  - » Test your fields to know your numbers
  - » Rotate resistant varieties
  - » Rotate to non-host crops
  - » Consider using a nematode protectant seed treatment

### Rotate Resistant Varieties

- If your SCN populations are found to be increasing, select varieties with sources of resistance other than PI88788.
- The most common source of resistance other than PI88788 is PI548402 or “Peking” resistance.

### Rotate to Non-Host Crops

- Rotation to a non-host crop to reduce SCN pressure.
- Corn, alfalfa and small grains are the most common non-crop choices for reducing SCN numbers.
- Since SCN persists in the soil for many years, it cannot be totally eradicated by rotation.

### Seed Treatments

- Several nematicide seed treatments with activity against SCN are currently available and can provide added protection when used with a SCN-resistant soybean variety.
- Nematicide seed treatments are intended to supplement current SCN management strategies, not replace them. Seed treatments should therefore be used in coordination with SCN-resistant varieties and rotation to non-host crops.
- The LumiGEN™ system offering includes ILEVO® HL fungicide/nematicide seed treatment, which has activity against SCN.

# Soybean Seeding Rate Considerations

Mark Jeschke, Ph.D., Agronomy Manager

*"Soybeans are generally less affected by seeding rate than some other crop species such as corn due to the inherent adaptability of the plant."*

- Soybean yield is generally less sensitive to plant density than crops such as corn; however, establishing an adequate stand is still important for maximizing yield potential.
- Average soybean seeding rates in the U.S. have trended lower in recent years for a number of reasons, including advances in seed treatments and better planter technology.
- An analysis of more than 200 soybean seeding rate studies in the U.S. and Canada showed that optimum seeding rates were higher in more northern and less productive environments.
- Soybean seeding rates should be high enough to provide some degree of protection against less-than-ideal conditions at emergence, which can reduce stand establishment.
- A dense soybean canopy can help suppress weeds; a benefit that may be more important to consider as herbicide-resistant weeds become more prevalent.
- Several additional factors should be considered in soybean seeding rate decisions on a field-by-field level, including soil type, planting date, and seedbed condition.

## SEEDING RATE DECISIONS

The number of seeds to plant per acre is a decision that crop producers must make each year and is important for maximizing the yield potential of the crop. In general, the objective is to plant seeds at sufficient density to maximize light capture and yield potential but avoid planting more seeds than necessary, which would incur additional seed cost and could potentially have a detrimental effect on the crop due to increased competition among the plants for resources.

Seeding rates are often targeted toward an agronomic or economic optimum. The agronomically optimum seeding rate is the minimum seeding rate necessary to maximize yield potential. The economically optimum seeding rate is the seeding rate at which economic return is maximized. The economic optimum is always slightly less than the agronomic optimum and varies depending on seed cost and grain price.



Soybeans are generally less affected by seeding rate than some other crop species such as corn due to the inherent adaptability of the plant. The ability of soybean plants to increase their lateral branching in low density environments give them some capacity to compensate for poor stand establishment. Soybeans also generally experience some degree of natural plant attrition during the growing season, which greatly reduces any potential risk of reduced yield and agronomic performance associated with high plant density.

Historically, the relatively low sensitivity of soybeans to plant density, coupled with low seed cost, meant that optimizing seeding rates in soybeans was not particularly critical. As a result, seeding rate practices varied widely across different environments and agronomic practices. Increasing soybean seeding rates in more stressful environments provided cheap insurance against poor stand establishment. Seeding rates in excess of 200,000 seeds/acre were not uncommon for soybeans planted with a drill in no-till systems.

In recent years, a number of factors have reduced the need for elevated seeding rates to guard against poor stand establishment as well as increased the incentive to bring seeding rates into closer alignment with economic optimums. Consequently, average seeding rates for soybeans have steadily declined over the past couple of decades and have become more uniform across geographies.

As seeding rates have declined, the risk of reduced yield associated with poor stand establishment has become more of an issue. At the same time, recent research has shown a greater yield benefit to early soybean planting (Van Roekel, 2019), making it important to ensure adequate stand establishment upon initial planting, especially in more stressful early-season conditions, and avoid the need for replant.



## SOYBEAN SEEDING RATE TRENDS

Soybeans differ from corn in some important ways with regard to seeding rate response and trends in grower practices over time. Seeding rates in corn have steadily increased over time, with agronomic optimum rates increasing from around 30,000 plants/acre 35 years ago, to over 37,000 plants/acre today (Assefa et al., 2018). Greater plant density has been the primary driver of corn yield gain over time, as breeding has improved stress tolerance in corn and the ability of plants to produce consistent ears at higher plant densities.

Soybeans, however, do not have the same degree of correlation between plant density and yield. Historically, soybeans were often seeded at rates well over 200,000 seeds/acre. However, since the turn of the century, seeding rates have steadily declined to an average of around 147,000 seeds/acre in 2022 (Corteva Agriscience Grower Survey) even as soybean yields have continued to increase. There are several factors that have contributed to these divergent trends:

**Breeding for greater yield per plant.** Research on genetic gain in soybeans has shown that newer soybean varieties have a greater ability to compensate for low plant density by producing more yield on the branches of the plants (Suhre et al., 2014). This has reduced the yield penalty risk associated with suboptimal plant density.

**Higher seed cost.** Soybean seed cost per acre has nearly doubled since 1997 (accounting for inflation) with the increased yield potential and herbicide tolerance traits of modern varieties (USDA-ERS, 2023). This higher cost has created a greater incentive to optimize soybean seeding rates for economic return.

**Improved planting accuracy.** Historically, a substantial portion of soybean acres were planted with drills, which made higher seeding rates necessary to compensate for the relatively low

accuracy of seed placement. However, the trend away from planting soybeans with drills in favor of row crop planters and improved seed placement with newer precision drills has reduced this need (Jeschke and Lutt, 2016).

**Adoption of seed treatments.** Advances in seed treatments and their widespread adoption by growers have increased the resilience of soybeans against stressful conditions after planting, reducing the need to use higher seeding rates to protect against poor stand establishment. Pioneer field studies conducted in the early-2000s showed that fungicide + insecticide seed treatments improved soybean stand establishment with early planting compared to non-treated seed and reduced the economically optimum seeding rate by an average of 5% with normal planting dates and 14% with early planting dates (Trybom et al., 2009; Trybom, 2009).

**Herbicide tolerance traits.** The widespread adoption of soybean varieties with herbicide tolerant traits beginning in the 1990s allowed for more effective post-emergence weed control in soybeans, reducing the need to rely on higher soybean density as a cultural tool for suppressing weed growth.



## IMPACT OF YIELD ENVIRONMENT

Another important difference between soybean and corn seeding rate response is the effect of yield environment on optimum plant density. The optimum plant density for corn generally increases as productivity increases. Recent Corteva Agriscience plant population research showed that the economic optimum seeding rate increased from approximately 30,000 seeds/acre at a yield level of 150 bu/acre to around 37,000 seeds/acre at a yield level of 240 bu/acre (Jeschke, 2019). Research in soybeans, however, has shown the opposite trend. A recent analysis of more than 200 soybean seeding rate studies in the U.S. and Canada showed that soybean producers should increase seeding rates in areas of lower productivity and decrease seeding rates in areas of higher productivity (Gaspar, 2019).

One hypothesis for why this relationship has been observed has been that areas of low productivity have lower initial stand establishment and/or greater plant attrition over the course of the growing season, resulting in a lower harvest stand. However, research has found that stand establishment is not generally affected by yield level, regardless of geographical location in the U.S. Likewise, plant attrition during the growing season does not appear to differ according to yield level (Gaspar, 2019).

The need for higher soybean seeding rates in lower productivity environments is primarily due to limitations on plant growth rate and branching. Plant growth can be limited due to many factors, such as precipitation, soil water-holding capacity, nutrient supply, rooting depth, etc. These factors, most commonly limiting in low productivity areas, can challenge the ability of soybean plants to maximize season-long light interception. Increased plant density is therefore required to maximize light interception and yield in these lower productivity environments.

## SOYBEAN SEEDING RATE RESEARCH

Soybean yield response to seeding rate has been studied in numerous field experiments over the years. Results of these studies have often varied widely. Some studies have determined that 100,000 plants/acre at harvest time are required to maximize light interception and thus yield (Gaspar and Conley, 2015;

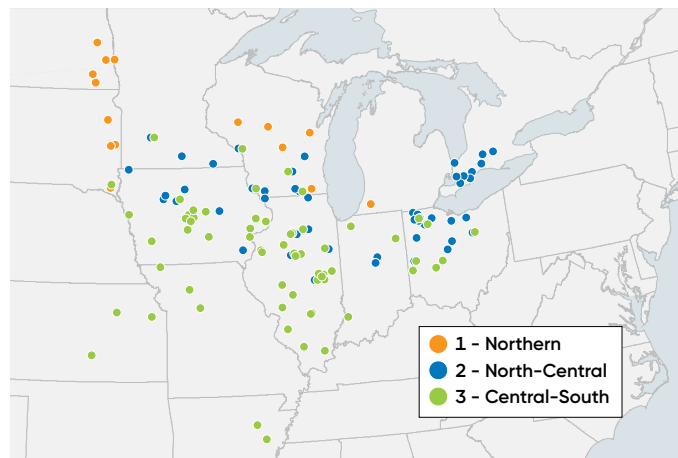
○ *"Soybean producers should increase seeding rates in areas of lower productivity and decrease seeding rates in areas of higher productivity."*

Lee et al., 2008) while other studies have shown economically optimal seeding rates ranging from 95,000 to 130,000 seeds/acre (Gaspar et al., 2017). However, these studies were often conducted in very uniform, well drained, and highly productive fields. Other field studies conducted in more stressful environments have suggested seeding rates as high as 243,000 plants/acre are needed to maximize soybean yield (Holshouser and Whittaker, 2002). Thus, there appears to be a wide range of agronomically and economically optimal seeding rates and plant stands that depend on seed costs, grain prices, seed treatment use, and – most importantly – the inherent productivity of the environment.

A recent study by Gaspar et al. (2020) pulled together data from a large number of soybean seeding rate field studies to quantify the production risk associated with soybean yield response to seeding rate and plant density from a range of environments across North America. Soybean seeding rate and yield data were compiled from 211 soybean seeding rate field experiments conducted across 12 U.S. states and Ontario from 2005 to 2017. Cluster analysis was used to group field studies into similar growing environments based on GPS



coordinates, soil characteristics, and weather variables. This analysis grouped research locations into three clusters with distinct latitudinal separation, with one cluster comprised of northern Corn Belt locations, one that covered many of the central Corn Belt and southern locations, and one between the two that partially overlapped both (Figure 1).



**Figure 1.** Locations of 211 trial site-years and environmental clusters of soybean seeding rate experiments analyzed by Gaspar et al. (2020).

**Table 1.** Average soybean yield in high, medium, and low yield groupings by environmental cluster of soybean seeding rate experiments analyzed by Gaspar et al. (2020).

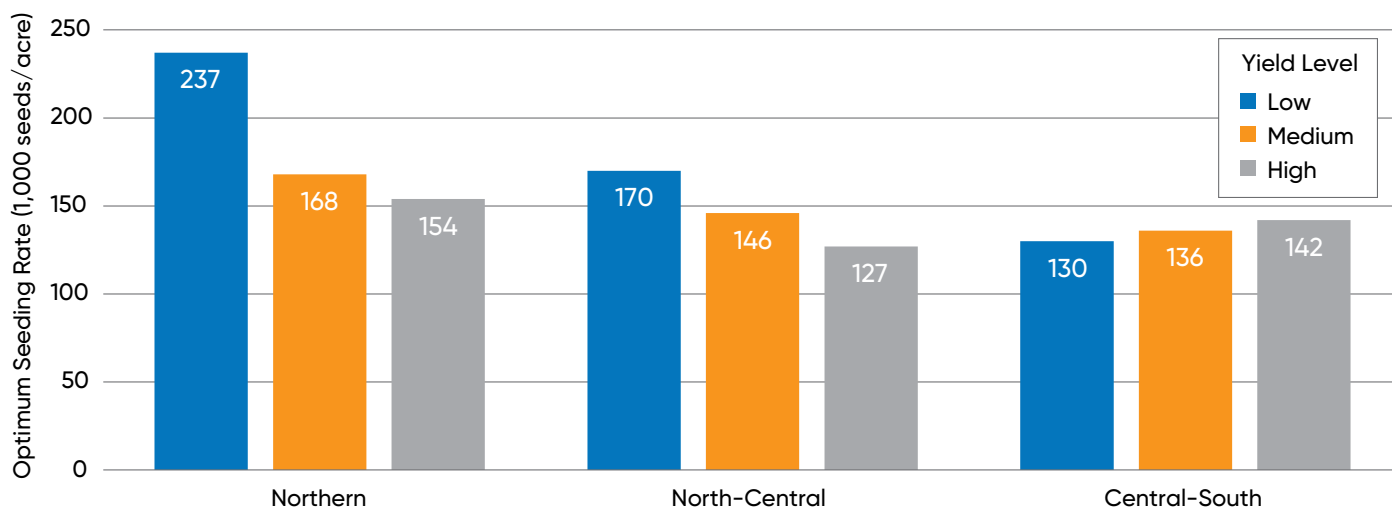
Environmental Cluster	Soybean Yield Level		
	High	Medium	Low
	————— bu/acre —————		
Northern	81.7	67.6	46.1
North-Central	82.3	68.0	54.4
Central-South	81.9	70.3	55.1

Locations within each cluster were further subdivided into low, medium and high yield groupings, comprised of the lowest 30%, the middle 30–70% and the upper 30%, respectively (Table 1).

Although the yield level groupings spanned a wide yield range in all three environmental clusters, all yield level groupings were relatively high, reflecting the fact that field studies tend to be conducted in high-productivity environments. For example, the low, medium, and high yield group averages for the Northern cluster were 46.1, 67.6, and 81.7 bu/acre, respectively. The average soybean yield as reported by USDA-NASS for the states represented in this cluster over the years of the study period was only 40 bu/acre.

Agronomically optimum seeding rates varied among environmental clusters and yield level groupings (Figure 2). Optimum seeding rates tended to be greater in more northern environments, as were the differences among yield levels. The Northern and North-Central clusters reflected findings of previous research that showed optimum seeding rates for soybean tended to increase in lower yielding environments. The Central-South cluster, however, did not exhibit this same trend. Optimum soybean seeding rate in this cluster increased with yield level but only slightly, with only 12,000 seeds/acre separating the high and low levels.

The difference in yield level trends between the Northern and North-Central clusters and the Central-South cluster may be attributable to the role of plant density in maximizing light capture. Soybean yield is linearly related to the cumulative amount of light captured during the R1 to R5 growth stages (Van Roekel and Purcell, 2016), a relationship that is stronger in more northern environments where seasonal photosynthetically active radiation is more yield-limiting. In lower-yield environments, where plant growth rate is more limited, higher plant density would be more important in maximizing light capture in northern locations.



**Figure 2.** Agronomically optimum seeding rates for low, medium, and high-yielding trial locations in the Northern, North-Central, and Central-South environmental clusters in Gaspar et al. (2020).

## SOYBEAN SEEDING RATE CONSIDERATIONS

### Seeding Rate vs. Final Stand

An important consideration in soybean seeding rate decisions is the fact that the plant density of a stand of soybeans at the end of the season will often be considerably less than the number of seeds that went into the ground. Soybeans naturally undergo some amount of plant attrition during the growing season, so the number of plants per acre at the end of the season will not equal the number of plants that emerge. This is important when targeting a minimum final stand. The rate of attrition increases with plant density. Research has found that attrition rates of 10% to 20% are typical with current seeding rates. Assuming a 15% attrition rate, an initial plant stand of 120,000 plants/acre at V2 would result in a final stand of 102,000 plants/acre.

Germination and emergence rates must also be taken into account, as not all seeds that are planted will germinate and not all of those that germinate will successfully emerge. Modern soybean seed treatments have improved stand establishment rates by protecting germinating and emerging seedlings from soil-borne pathogens. However, abiotic factors such as soil crusting, crop residue, and imbibitional chilling can still impact emergence rates.

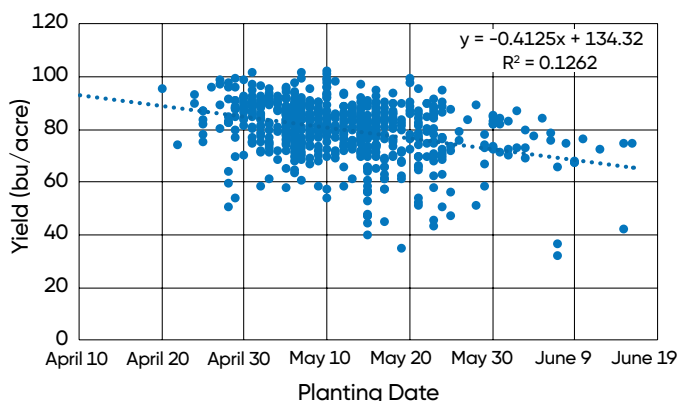


**Figure 3.** Emerging soybeans in dry, crusted soil at the Johnston Field Research Center in 2018, showing some seedlings that broke off during the emergence process.

Figure 3 shows a scenario in which weather conditions following planting impacted soybean stand establishment at the Corteva Agriscience research center at Johnston, IA. The field experienced heavy rain after planting followed by an abrupt transition to hot and dry conditions, resulting in soil crusting. As the soil dried out, many later-emerging soybean seedlings were unable to pull their cotyledons free from the soil and snapped at the hypocotyl. Soybean stand loss was around 10%. The seeding rate in this field was 140,000 seeds/acre. Assuming a 90% germination rate and 10% plant attrition during the season, early season stand loss likely reduced final stand in this field to just above 100,000 plants/acre.

	Normal Stand	Reduced Stand
<b>Seeding Rate</b>	<b>140,000</b>	<b>140,000</b>
germination	0.9	0.9
<b>Germinated</b>	<b>126,000</b>	<b>126,000</b>
emergence	1	0.9
<b>Emerged</b>	<b>126,000</b>	<b>113,400</b>
attrition	0.9	0.9
<b>Final Stand</b>	<b>113,400</b>	<b>102,060</b>

Soybean seeding rates should be high enough to provide some degree of protection against less-than-ideal conditions at emergence. Pushing seeding rates too low can increase the risk of needing to replant if everything does not go exactly right. Replanting soybeans can mean losing some of the higher yield potential with timely planting. Recent data suggest that modern soybean varieties have a greater yield response to earlier planting (Propheter and Jeschke, 2017; Van Roekel, 2019), making timely planting important to maximize yield potential (Figure 4). Earlier planting allows soybeans to take advantage of longer daylengths during mid-summer and can extend the duration of reproductive growth (Parker et al., 2016).



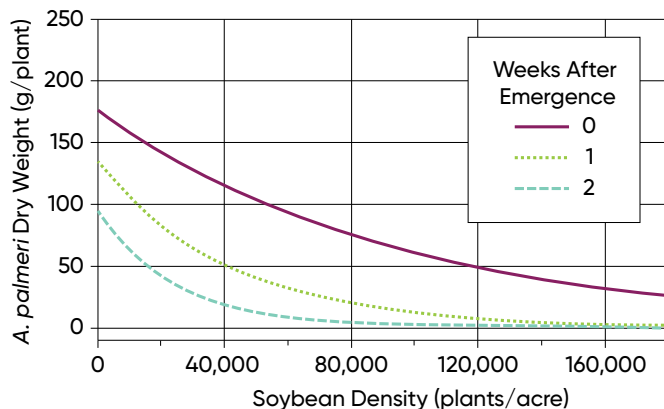
**Figure 4.** Soybean yield by planting date from four years of on-farm trials in Nebraska and Kansas (Propheter and Jeschke, 2017).

## WEED MANAGEMENT

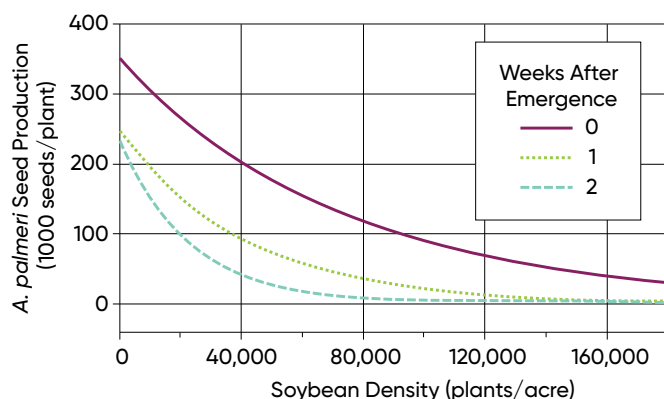
Weed management is becoming a more important consideration for soybean seeding rate and row spacing decisions in some cases. The ability of soybeans to suppress weed growth through canopy closure and reduced light transmission to the soil surface was historically an important consideration for both soybean seeding rate and row spacing. The denser the canopy and the earlier it closes the space between rows, the greater its ability to suppress weeds. The advent of herbicide resistance technologies, beginning with glyphosate-resistant soybeans in the mid-1990s, brought improved post-emergence weed control and reduced the need to rely on cultural practices to manage weed populations. However, the evolution and spread of glyphosate resistant populations of many weed species in subsequent years has reduced the effectiveness of chemical weed control and brought cultural practices back to the forefront as important tactics to consider for managing weeds.



A field research study on the effects of soybean plant density on the growth of Palmer amaranth (*Amaranthus palmeri*) showed that plant density can have an important effect on weed growth and seed production. The study found that both biomass (Figure 5) and seed production (Figure 6) of Palmer amaranth increased as soybean density decreased. The impact of soybean plant density was greater the earlier the Palmer amaranth plants emerged relative to the crop.



**Figure 5.** Effect of soybean density and Palmer amaranth emergence timing relative to the crop on Palmer amaranth dry weight per plant at harvest (Korres et al., 2020).



**Figure 6.** Effect of soybean density and Palmer amaranth emergence timing relative to the crop on Palmer amaranth seed production per plant at harvest (Korres et al., 2020).

### Additional Soybean Seeding Rate Considerations

Geographic region and yield level are the two most important factors to consider in soybean seeding rate decisions. However, several other factors may be important considerations in selecting a higher or lower seeding rate:

- o **Soil type.** Soils with high clay content are much more likely to crust and restrict soybean emergence, and can promote seedling diseases in wet springs.
- o **Planting date.** Early planting usually means colder, wetter soils, slower emergence, and reduced stands. Soybeans planted very late, including double-crop beans, require higher rates because they are destined to be shorter and produce fewer pods per plant.
- o **Tillage/residue cover/seedbed condition.** No-till systems provide a less hospitable environment for soybean emergence due to colder soils, more residue, and possible seed placement / soil contact challenges. Cloddy soils may also reduce seed-soil contact.
- o **Planter or drill.** Planters have traditionally done a better job of seed singulation and placement, increasing plant counts and stand uniformity. Growers using drills may need higher seeding rates to establish equally productive stands.
- o **Seedling disease risk.** Some regions have higher seedling disease risk due to soil types, weather patterns, and pathogen race shifts. Higher seeding rates are needed to establish target stands in areas or fields with a history of higher disease risk.
- o **Iron deficiency chlorosis risk.** Recent research studies have shown the value of high seeding rates in reducing chlorosis symptoms.
- o **White mold risk.** In fields with a historically high risk of white mold, very high seeding rates are not recommended.

# Herbicide System Effects on Waterhemp Emergence in Soybeans

Chris Olbach, Area Agronomist and Maggie Durnin, Intern

## ○ KEY FINDINGS

- → Aggressive, season-long emergence and resistance to multiple herbicides in waterhemp presents new challenges to weed management on Ontario farms.
- → Soil-applied residual herbicides applied pre-emergence provided foundational value for control of waterhemp.
- → New flushes of waterhemp emergence were observed though August and September, demonstrating the need to utilize residual herbicides along with cultural management practices for control of waterhemp.

## WATERHEMP IN ONTARIO

- The number of herbicide tolerant weeds in Ontario is increasing.
- The development and spread of multiple-herbicide-resistant (MHR) waterhemp (*Amaranthus tuberculatus* var. *rudis*) is of particular concern to weed control specialists and farmers alike.

## PHYSIOLOGY OF WATERHEMP

- Waterhemp – while hard to distinguish from many other *Amaranthus* species early in the season – bears unique physiological characteristics that contribute to its success as a weed.
- Prolific seed production, high growth rate, and season-long emergence alone make waterhemp a very competitive weed with which to contend (Costea et al., 2005).
  - » A single female waterhemp will produce 35,000-1,200,000 seeds per plant – nearly 1.5x other pigweed species.
  - » Waterhemp can grow at a rate of 1"-1¼" per day under optimal conditions (United Soybean Board, 2017).



**Figure 1.** High waterhemp density in soybeans in Ontario.



**Figure 2.** Waterhemp pressure as of June 6, 2023 – just prior to pre-emergence herbicide application (Haldimand County, ON).

- » The majority of waterhemp emergence occurs from June to August in Ontario but has been observed to continue as late as October.

## WATERHEMP AND HERBICIDE RESISTANCE

- The prevalence of herbicide resistance in waterhemp further complicates effective management.
- Multi-herbicide resistance in waterhemp – while aggravated by selection pressures – can be quickly achieved and spread through its dioecious reproduction (Costea et al., 2005).
- Unlike self-pollinating species of pigweed, waterhemp must reproduce by means of outcrossing pollen from male plants to receptive females nearby (Figure 3).
- Mandatory outcrossing in waterhemp results in a high degree of recombinant genetic diversity (Montgomery et al., 2019).
- Most waterhemp populations in Canada carry resistance to two or more herbicide groups, including: Group 2, 4, 5, 9, 14 and 27.

## OBJECTIVES

- In 2023, Pioneer agronomists commissioned a study involving a population of MHR waterhemp in soybeans in Ontario.
- The objective of this project was twofold:
  - » Study the physiology of the weed in Ontario crop production with respect to emergence over time.
  - » Evaluate herbicide program effects on waterhemp emergence in soybeans.



**Figure 3.** A comparison of *Amaranthus* species from the same field showing the dioecious nature and differentiation of waterhemp (far left and left) in comparison to green (right) and redroot (far right) pigweed respectively. Smooth stems are a key differentiating characteristic of waterhemp.

## STUDY DESCRIPTION

- o The experiment was conducted in a field in Haldimand County, Ontario, planted to soybeans in 2023 that was known to contain a population of waterhemp resistant to multiple herbicide modes of action (Group 2, 5, 9 and 14).

### Planting Date:

» June 5, 2023

### Soil Type:

» Haldimand clay

### Variety/Brand:

» P25A16e™ (E3)

### Previous Crop:

» Soybeans

### Seeding Rate:

» 190,000 seeds/acre

### Tillage System/Row Width:

» No-till on 15" rows

### Experimental Design:

» Two herbicide programs were compared, a POST-only program and a PRE + POST program:

### Treatments:

#### PRE

Applied: June 6, 2023

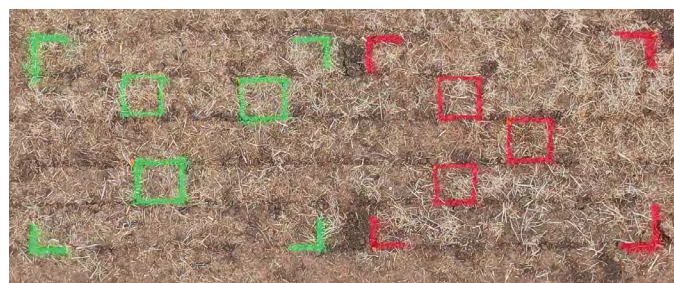
- Metribuzin (5) @149g/ac
- Glyphosate (9) @ 1.25L/ac
- Saflufenacil (14) @ 30ml/ac
- Pyroxasulfone (15) @ 100ml/ac
- S-Metolachlor (15) @ 628g/ac

#### POST

Applied: July 12, 2023

- 2,4-D Choline (4) @ 0.75L/ac
- Glyphosate (9) @1.25L/ac

- o The two herbicide programs were applied to six-by-eight-foot plots with three replicates each.
- o Both PRE and POST treatments were applied by a John Deere® 4730 self-propelled sprayer with 100-foot boom.

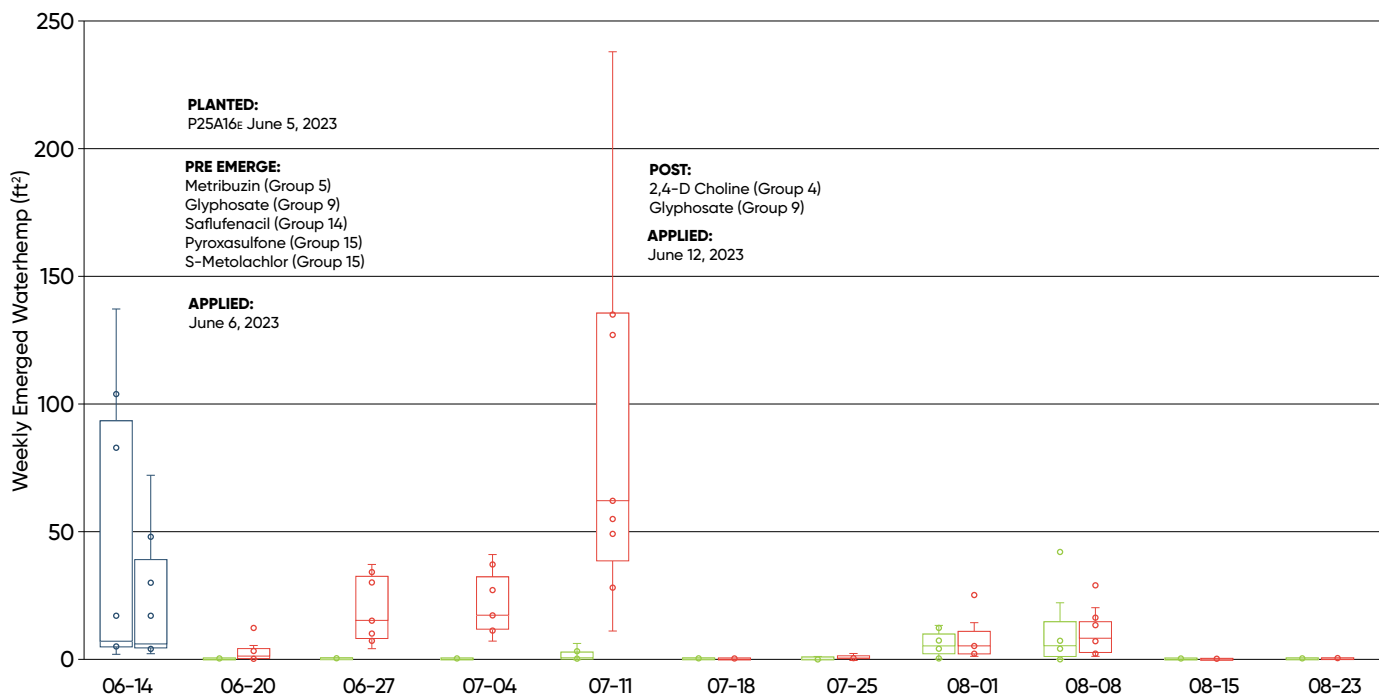


**Figure 4.** Layout of quadrats within two six-by-eight-foot treatment plots.

- o Six-by-eight-foot heavy tarps were used to cover plots prior to the PRE herbicide application to create the POST only treatments.

### Data Collection:

- o Three 1 ft<sup>2</sup> quadrats were randomly placed within each plot in which waterhemp emergence was recorded (Figure 4).
- o The positions of the quadrats were fixed for the duration of the experiment.
- o Waterhemp emergence was recorded before the PRE application and then weekly for the next 10 weeks.
- o Emerged waterhemp seedlings were counted within each quadrat and documented.
- o After newly emerged waterhemp seedlings were counted each week, they were eliminated with an application of Liberty®200 SN using a backpack sprayer.



**Figure 5.** Cumulative waterhemp emergence at the time of PRE herbicide application (recorded June 6, 2023, black bars in chart) and weekly emergence of new waterhemp seedlings for the next 10 weeks in POST-only and PRE+POST herbicide programs.

## RESULTS

- The PRE treatment was very effective in reducing waterhemp emergence. Emergence of new waterhemp plants was very low during the time between PRE and POST applications.
- Waterhemp emergence was prolific during the POST-only program, with 81% of the total seasonal emergence occurring between application timings.
- Peak waterhemp emergence in the POST-only program was the week of July 5-11, with an average of 94 plants per square foot.
- The POST treatment largely prevented emergence of new waterhemp plants for two weeks following application in both herbicide programs.
- A flush of new emergence was observed in both herbicide programs during the month of August, after residual activity of the herbicide treatments had faded.
- Counts were discontinued after August 23, as the crop had achieved canopy closure and no new emergence had been observed for two weeks. However, another flush of emergence occurred in September that was not recorded in this study.
- The PRE + POST program had much lower total waterhemp emergence over the season than the POST-only program.

- An average of 18 plants per square foot of waterhemp was recorded for the duration of the study in the PRE + POST program.
- An average of 154 plants per square foot was recorded over the study in the POST-only program.

## CONCLUSIONS

- Achieving full-season waterhemp control in the Ontario soybean crop is of growing interest to farmers as waterhemp moves and adapts its way across the rural routes of the province.
- Managing MHR populations of waterhemp effectively will require a more diligent approach to herbicide use – incorporating strong residual programs with effective post-emergence treatments in the crop.
- Herbicides—while still an important tool in MHR waterhemp management in soybeans—should be coupled with other on-farm agronomic management strategies where possible, such as crop rotation with corn and winter wheat.

---

## Acknowledgments

Grace Jones, Corteva Territory Manager  
Southcoast Agronomy & Lenos Custom Farming Ltd.

---

# Plenish<sup>®</sup> High Oleic Soybeans for On-farm Feeding

Nelson Lobos, Ph.D., Senior Nutritionist

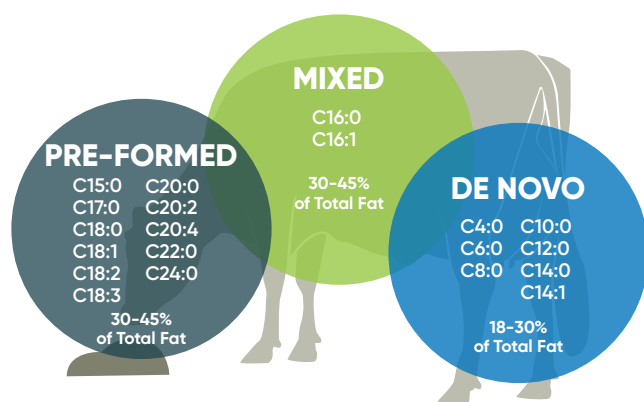
## MILK SOLIDS FOR DAIRY FARM PROFITABILITY

There has been a surge in demand for milk protein and butterfat in the U.S., which has resulted in elevated prices for these milk components. To boost milk fat content, dairy farms have widely adopted feeding fat supplements that are high in palmitic acid (C16:0). However, it's necessary to keep feeding costs under control to maximize profit when milk prices are strong.

Since feed costs make up approximately 50% of milk production costs, using homegrown feeds saves money and can be an effective strategy to boost profits. This strategy also helps mitigate the risk of supply chain disruptions that could impact feed availability.

One promising option for homegrown feed is Plenish beans, which offer a high energy and protein feed with a desirable fatty acid profile that can replace expensive fats in the ration. The high oleic (C18:1) and low linoleic (C18:2) content of Plenish beans allows for higher dietary inclusion levels than commodity soybeans. By incorporating Plenish beans into their feeding regime, dairy farms can potentially reduce costs and improve profitability while maintaining, even improving, milk fat content.

## THE TWO SOURCES OF MILK FAT: PRE-FORMED FROM DIET OR BODY RESERVES AND DE NOVO SYNTHESIS



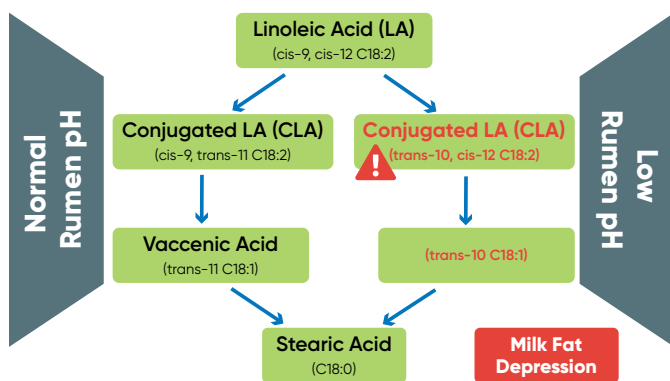
Pre-formed fatty acids originate from mobilized reserves or from the diet. After digestion and absorption, the udder takes these fatty acids from circulation and incorporates them into milk fat.

In addition, cows can synthesize fat in the udder (de novo) from simple volatile fatty acids, such as acetate and butyrate, precursors that derive from the fermentation of fiber by rumen microbes. Cows can assemble fatty acids de novo up to 16 carbons in length.

## THE ROLE OF FATTY ACID QUANTITY AND QUALITY IN DAIRY COW METABOLISM AND PRODUCTION.

All rations fed to dairy cows contain fat, which can come from a variety of sources including fat supplements, forages, grains, and byproducts. The type of fat in the diet can be either saturated (no double bonds), such as palmitic acid, or unsaturated (one or more double bonds), such as linoleic acid. However, excessive dietary polyunsaturated fatty acids, also known as PUFA load, can impair activity of fiber-digesting rumen microbes.

Ruminal biohydrogenation is a process that normally converts unsaturated fatty acids to saturated fatty acids, detoxifying the PUFA. But, when normal ruminal fermentation is altered by low rumen pH or the mechanism is overwhelmed by excessive PUFA load, it can lead to **alternative intermediates** that cause Milk Fat Depression (MFD).

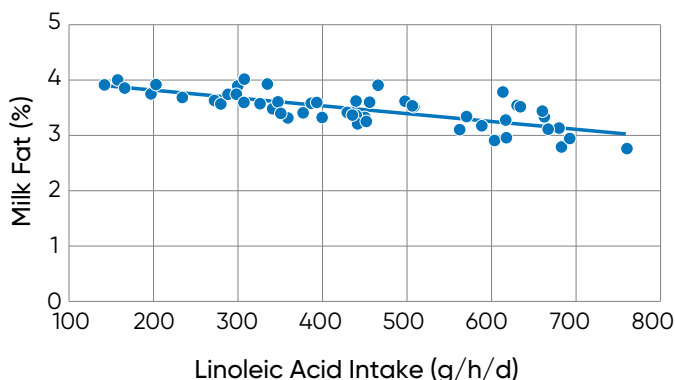


Conjugated linoleic acid (CLA) formation is part of the biohydrogenation process, but **trans-10, cis-12 CLA** formed during low ruminal pH is a potent, undesirable CLA linked to milk fat depression. Research shows that even just 3-4 grams reaching the intestines can dramatically reduce milk fat synthesis (Overton, 2017).

## COMMON FEEDS HIGH IN LINOLEIC ACID: CORN SILAGE, CORN GRAIN, SOYBEANS, AND THEIR BYPRODUCTS

Corn silage is the primary forage choice for dairy farmers due to its high tonnage, nutritional qualities, and cost-effectiveness. However, even though it is low in fat content, it contains a significant amount of linoleic acid. When included in large amounts, corn silage can add to the ruminal PUFA load, which has been linked to decreased milk fat percentage (Diaz, 2020).

It's important to note that milk fat depression can be caused by multiple concurring factors, including PUFA intake, fermentable starch, slug-feeding, and more. To successfully include high levels of corn silage in dairy rations, it's essential to pay close attention to excessive ruminal starch digestion and lack of dietary effective fiber, in order to mitigate the risk of milk fat depression.



Source: Diaz, 2020

### PLENISH SOYBEANS: HIGH IN OLEIC ACID AND LOW IN LINOLEIC ACID COMPARED TO COMMODITY SOYBEANS

Soybeans are a valuable source of protein, that also contain a high level of fat at about 20%. Roasting is a common practice to prevent rancidity, enhance palatability, and improve ruminal undegraded protein (RUP). However, feeding commodity soybeans at high levels, especially when the oil in the beans is exposed through grinding, can lead to significant milk fat depression.

Plenish soybeans, with 75% oleic acid and only 9.5% polyunsaturated fatty acids (PUFAs, including linoleic), compared to conventional soybeans with 22% oleic acid and 63% PUFAs, represent a groundbreaking innovation in dairy nutrition, allowing for a shift in the way nutritionists formulate rations.

#### Commodity Soybean



#### Plenish® High Oleic Soybean



**Risk of MFD**

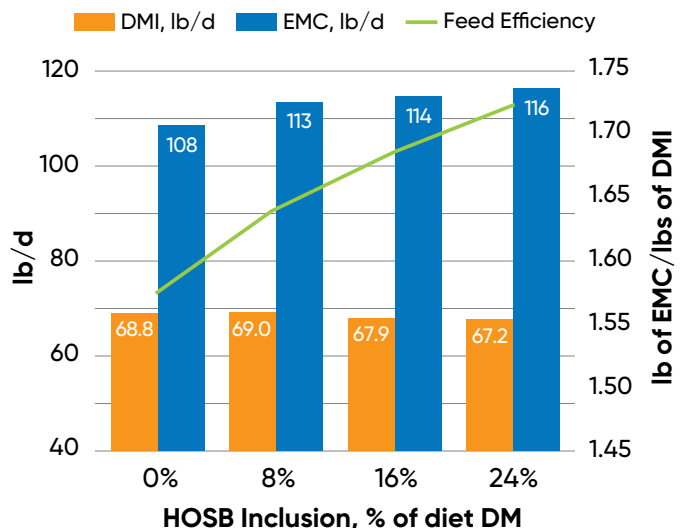
### SCIENTIFIC EVIDENCE: UNIVERSITY RESEARCH SUPPORTS POSITIVE EFFECTS OF PLENISH SOYBEANS

1. Penn State University (Lopes, 2017), researchers compared Plenish vs. commodity extruded soybean meal at the same inclusion rate (17% of diet DM), and same fat in the ration (4% of diet DM). Neither intakes nor milk yield were affected

(27 kg DM/d, and 42 kg/d). However, milk fat increased 0.2% (3.55% to 3.74%). In addition, it was reported that PUFA in milk decreased ~50% (from 4.93% to 2.49%), which is consistent with the fatty acid profile of the diets. Researchers concluded that high oleic beans are likely to increase milk fat concentration and yield, with no negative effects in intake, or the yields of milk or protein.

2. University of Wisconsin (Weld and Armentano, 2018), researchers compared Plenish and commodity soybeans fed either whole or ground. Inclusion was ~17% of diet DM and fat ~7% of diet DM. Intakes were not affected; however, milk fat increased when Plenish beans were fed ground (3.09% vs. 3.50%), but not when fed whole (3.40% vs. 3.53%). Similarly, milk fat yield increased significantly when Plenish beans were fed ground (1.49 vs. 1.64 kg/d), but not when fed whole.

3. Michigan State University (Bales and Lock, 2023), compared increasing rates of inclusion as high as 16 lb/d. Diets contained roasted Plenish beans (HOSB) at 0, 8, 16, and 24% of diet DM. Results indicated a decline of 1.6 lb/d in DMI with increasing levels of inclusion, thus improving feed efficiency. Milk and milk fat yield increased 9 lb/d and 0.35 lb/d, leading to an overall increase in energy corrected milk (ECM).



Source: Bales, 2023

### TO ROAST OR NOT TO ROAST?

Typically, roasting costs \$25-\$35 per ton. Losses by open flame roasting are near 12%; about half is water, the rest are pods and hulls that have feed value. If using electric or hot air, loss is mostly water. Improper roasting (too hot, too long) can decrease protein value, because its binding with sugars (Maillard reaction, ↑ADIN).

Roasting improves palatability and prevents oil rancidity. It doubles protein escape from the rumen (↑RUP, by-pass). In addition, denatures trypsin inhibitor and urease (thus allowing for urea use in rations).

If roasting is not possible, feeding quartered beans is better than whole.



# Optimum Plant Population for Corn Silage Yield and Quality

Dann Bolinger, M.S., Dairy Specialist

The optimum seeding rate and resulting plant population of corn for silage merits periodic revisiting. As corn hybrid genetics improve over time, yield potential and agronomic characteristics including stress tolerance tend to change for the better. A shift in the optimum plant population would logically be anticipated in accordance to these genetic advances. While recommended seeding rates for corn grown for grain purposes are regularly studied and fairly well understood, is there a need to differentiate recommendations for corn harvested as silage?

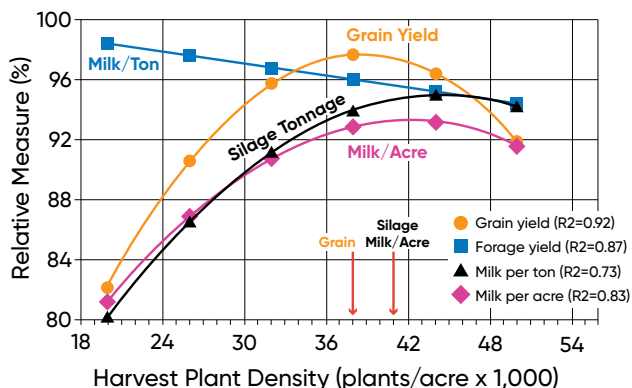
## MAXIMIZING CORN SILAGE YIELD

Since 1994, no less than ten university and Pioneer studies have been reported evaluating the relationship of seeding rate or plant density to silage yield. The most comprehensive data set (Lauer, 2010) concluded the optimal seeding rate for silage corn was about 3,000 or 8% seeds per acre more than the optimal rate for grain corn (Figure 1). This is consistent with a historically popular recommendation of corn silage being planted at a rate of 2,000 seeds per acre more than the recommended corn grain rate in a particular planting scenario.

**Studies and respective growing seasons with highest average tonnage at >40k plant rate:**

- Univ. of WI 1994-96
- Univ. of MD 1997-98
- Penn State Univ. 1998-99
- Univ. of Alberta 2002-03
- Pioneer Hi-Bred, CO 2004-07
- Univ. of WI 2000-08
- Cornell Univ. 2008-09
- Pioneer Hi-Bred, CO 2011
- Pioneer Hi-Bred, NY 2011
- Virginia Tech 2017

In all ten of the aforementioned silage corn population trials, average silage yield did not plateau until plant densities exceeded 40,000 plants per acre. Agronomic limitations typically arise well before populations of this magnitude. Water availability and standability are the most common considerations that curtail the optimum seeding rate well before tonnage yield is maximized.

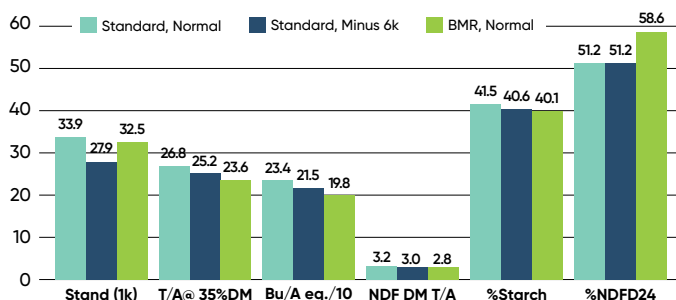


**Figure 1.** Relationship between corn plant density and grain yield, silage yield, milk per ton and milk per acre (Lauer, 2010). (n=447 plots)

## SILAGE QUALITY IMPLICATIONS

A commonly held perception is that lower corn plant populations result in higher quality corn silage. This belief is premised upon high ear-flex corn hybrids better maintaining grain yield with fewer plants, thus an assumption that silage starch content will increase with lower plant density. It is also reasoned that lower populations result in larger diameter corn stalks, thus a higher ratio of stalk pith to the less digestible stalk rind. While both ideas may seem reasonable, controlled data supports neither the starch content nor fiber digestibility claim. Results have either been inconsistent or have simply shown no impact of plant density on these quality parameters.

A recent field study (Bolinger, 2022 unpublished) showed high ear-flex hybrids decreased in all yield metrics (-1.6 T/A silage, -19 bu/A grain, - 0.2 DMT/A fiber), when planting rate was decreased by 6,000 seeds per acre (Figure 2). Thus, starch content was comparable (- 0.9%starch) at the lower population. Fiber digestibility was equal at the normal and reduced seeding rate. Regardless of plant density, standard hybrids had substantially lower fiber digestibility (-7.4%NDFD24) than brown midrib hybrids planted at normal seeding rates.



**Figure 2.** Normal seeding rate of standard high ear-flex hybrids compared to 6,000 fewer seeds/acre and brown midrib at normal seeding rate.

While a 2017 Virginia Tech study (Ferreira et. al., 2020) demonstrated that plant density is strongly correlated to silage yield ( $R^2 = 0.9899$ ,  $p < 0.01$ ) and stalk diameter ( $R^2 = 0.958$ ,  $p < 0.01$ ), plant density was not predictive of fiber digestibility ( $R^2 = 0.4891$ ,  $p < 0.12$ ). The conclusion was that increasing corn plant population had "minimal or no effects on corn silage composition or digestibility."

## PLANTING RATE RECOMMENDATIONS FOR CORN SILAGE

Seeding rate recommendations for corn as a grain crop are anchored in hybrid-specific knowledge combined with anticipated growing environment variables such as soil type, water availability, and fertility. Research suggests that silage corn seeding rates should be comparable to grain corn rates. An increase of 2,000 to 3,000 additional seeds per acre may increase silage yield without sacrificing quality, when agronomic considerations are not likely to be limiting.

# Dairy Perspective on Enogen<sup>®</sup> Feed Corn Hybrids

Nelson Lobos, Ph.D., Senior Nutritionist

## WHAT ARE ENOGEN FEED CORN HYBRIDS?

Enogen feed corn hybrids are transgenic corn with an enzyme technology (event 3272) marketed only by Syngenta. Enogen feed corn hybrids express a bacterial alpha-amylase, the enzyme is contained in the endosperm of the kernel and breaks down corn starch into sugar. This technology was originally designed for the ethanol industry to replace liquid fermentation enzymes used in ethanol production and promised added premium opportunities for growers. There has been limited adoption of Enogen feed corn hybrids among ethanol plants and corn growers. Recently, Syngenta began promoting Enogen feed corn hybrids as a superior feed for both grain corn and silage.

## WHAT ARE THEIR CLAIMS?

Syngenta claims that Enogen feed corn hybrids significantly increase starch and sugar availability in ruminant diets. In addition, claims of improved fiber digestibility have been made implying that Enogen feed corn hybrids feed similarly to brown midrib (BMR) hybrids.

## THE FACTS

**Enogen feed corn hybrids do not contain a BMR gene.** The Enogen alpha-amylase trait was developed to produce more ethanol from corn kernels in an industrial setting. There are no credible explanations why an amylase in the kernel would impact fiber digestibility.

**Enogen feed corn hybrids present no advantage in fiber digestibility.** Pioneer silage plots from 2017 showed no significant difference in fiber digestibility (NDFD, 24-hr) between Enogen feed corn hybrids and Pioneer brand non-BMR (standard) silage products, both of which demonstrated inferior fiber digestibility compared to Pioneer brand BMR products in the same trials.

	# of comp	Tons/acre 35% DM	Starch %	NDFD 24h
Pioneer (standard)	81	25.2	39.4	53.4
Enogen		24.0	37.4	53.6
Pioneer (BMR)	34	23.4	36.4	59.5
Enogen (non-BMR)		24.4	38.5	53.9

2017-2020 strip trial comparisons of Pioneer<sup>®</sup> versus Enogen feed corn products within five relative maturity units of each other (OH, MI, WI, IA, MN, SD, and NE).

## The alpha-amylase in Enogen feed corn hybrids does not work at rumen temperature.

The bacterial alpha-amylase is marketed as “robust” by Syngenta because remains active and stable in adverse conditions. In fact, the enzyme’s ideal working temperature range is 160°– 220° F. Clearly, Enogen is an industrial product not developed to work in animals, given that rumen temperature is quite lower and stable (101°–104° F) in healthy cows (Hu et. al., 2010).

## Enogen feed corn is not food-grade corn.

The bacterial alpha-amylase in Enogen feed corn can cause a number of corn food production issues like non-forming dough, crumbly chips, and soggy cereal (Erickson, 2018). Growing Enogen requires adherence to a stewardship protocol (Syngenta, 2018). Nevertheless due to the potential of Enogen contamination, markets like ethanol production, grain handling and grain milling (Holdgreve, 2009) require continuous inbound testing for the Enogen GMO trait to manage the risk of contamination (Envirologix, 2022).

## Growing Enogen feed corn takes away flexibility compared to any other regular commodity corn

In addition to 30-foot physical or border rows, the stewardship protocol requires cleaning all equipment used in planting, harvest, transport, and storage. Upon harvest, all grain and/or silage must be segregated from non-Enogen corn. Moreover, the closed-loop system forces the grower to commit the crop for animal feed and prevents from selling into the commodity



grain even if the market economics are favorable.

**Animal trial data is very limited on Enogen feed corn.**

Note that data collected in beef cattle has little value for dairy, because intakes, as well as fiber and starch levels fed are not comparable. In addition, responses in beef cattle were reported only when Enogen corn was fed not fermented, but as whole grain or coarsely cracked.

To date, there are only four peer-reviewed university trials in which Enogen corn was fed as silage to dairy cows. All trials used the corresponding isogenic counterpart (background hybrid minus the alpha-amylase transgene) as control. Across trials, silage was fed at 40% of diet DM.

1. **Cueva et al., 2021 (PSU).** This study reported **no differences** in starch digestibility. Further, significant differences in starch content, with the Enogen hybrid having 3% units more starch confounds the results as starch content is unrelated to alpha-amylase present in corn. Silage was fermented for 220 days.
2. **Cueva et al., 2022 (PSU).** Replacement of normal corn silage with Enogen, failed to have **any effect** on dry matter intake, milk yield, or energy corrected milk. Starch digestibility was not reported. Feed efficiency declined from 1.47 to 1.32 kg milk/kg DMI on Enogen fed cows.
3. **Krogstad et al., 2022 (MSU).** Effects of Enogen on milk yield, milk components yield, and dry matter intake were all reported as **non-significant**. Whereas increasing starch from 25% to 30% of diet DM increased both milk

yield and feed efficiency regardless of the diet containing Enogen or its non-amylase isogenic hybrid. The study failed to detect any benefit of alpha-amylase when feeding a higher starch diet. Silage was fermented for 41 days.

4. **Rebelo et al., 2023 (OSU).** This study compared Enogen with its isogenic hybrid fed as silage or as ground grain. Silages were similar in DM (30%), and starch (35% of DM), however, ground grain differed in particle size (1.05 vs. 0.65 mm). Intakes were higher in cows fed Enogen (58.8 vs. 55.3 lb/d), as well as milk yield (77.8 vs. 72.9 lb/d). No differences reported on milk fat, milk protein, or energy corrected milk. The study found **no differences** in ruminal digestibility of dry matter, organic matter, starch or NDF. Total-tract apparent starch digestibility was highest in the isogenic control (98.3%) compared to Enogen.

Overall, published dairy research indicates no consistent effect on intakes, milk yield or starch digestibility that could justify feeding Enogen feed corn.

The summary table below, presented in May, 2023 (Ferraretto, 2023) by Dr. Luiz Ferraretto (UW-Madison Dairy Extension Specialist), included his recommendation for caution in interpreting results given the limited research data. Moreover, he also stated that the mechanism behind field-reported production responses is still uncertain. In other words, there is not enough research available to substantiate the claims or to link observed responses to the expression of alpha-amylase in Enogen corn.

Study	DMI, lb/day	Milk Yield, lb/day	ECM, lb/day	Fat, %	Feed Efficiency, lb milk/lb DMI	Total Tract Starch Digestibility, % of intake
PSU Cueva et al., 2021	No diff	+4.4	No diff	No diff	+0.08	No diff
PSU Cueva et al., 2022	No diff	No diff	No diff	NR	-0.15	NR
MSU Krogstad et al., 2022	No diff	No diff	No diff	No diff	No diff	NR
OSU Rebelo et al., 2023	+3.4	+7.6	No diff	Lower	No diff	Lower



# Beef Perspective on Enogen® Feed Corn Hybrids

Nelson Lobos, Ph.D., Senior Nutritionist

## WHAT ARE ENOGEN FEED CORN HYBRIDS?

Enogen feed corn hybrids are transgenic corn with an enzyme technology (event 3272) marketed only by Syngenta. Enogen feed corn hybrids express a bacterial alpha-amylase, the enzyme is contained in the endosperm of the kernel and breaks down corn starch into sugar. This technology was originally designed for the ethanol industry to replace liquid fermentation enzymes used in ethanol production and promised added premium opportunities for growers. There has been limited adoption of Enogen feed corn hybrids among ethanol plants and corn growers. Recently, Syngenta began promoting Enogen feed corn hybrids as a superior feed for both grain corn and silage.

## WHAT ARE THEIR CLAIMS?

Syngenta claims that Enogen feed corn hybrids significantly increase starch and sugar availability in ruminant diets. In addition, claims of improved fiber digestibility have been made implying that Enogen feed corn hybrids feed similarly to brown midrib (BMR) hybrids.

## THE FACTS

**Enogen feed corn hybrids do not contain a BMR gene.** The Enogen alpha-amylase trait was developed to produce more ethanol from corn kernels in an industrial setting. There are no credible explanations why an amylase in the kernel would impact fiber digestibility.

**Enogen feed corn hybrids present no advantage in fiber digestibility.** Pioneer silage plots from 2017 showed no significant difference in fiber digestibility between Enogen feed corn hybrids and Pioneer brand non-BMR silage products; both of which demonstrated inferior fiber digestibility compared to Pioneer brand BMR products in the same trials.

	# of comps	Tons/acre 35% DM	Starch %	NDFD 24h
Pioneer (standard)	81	25.2	39.4	53.4
Enogen		24.0	37.4	53.6
<b>Pioneer Advantage</b>		<b>1.2</b>	<b>2.0</b>	<b>-0.2</b>
Pioneer (BMR)	34	23.4	36.4	59.5
Enogen (non-BMR)		24.4	38.5	53.9

2017-2020 strip trial comparisons of Pioneer® versus Enogen feed corn products within 5 relative maturity units of each other (OH, MI, WI, IA, MN, SD, and NE).

### The alpha-amylase in Enogen feed corn hybrids does not work at rumen temperature.

The bacterial alpha-amylase is marketed as “robust” by Syngenta because remains active and stable in adverse conditions. In fact, the enzyme’s ideal working temperature range is 160° – 220° F. Clearly, Enogen is an industrial product not developed to work in animals, given that rumen temperature is quite lower and stable (101°–104° F) in healthy cows (Hu et al, 2010).

### Enogen feed corn is not food-grade corn.

The bacterial alpha-amylase in Enogen feed corn can cause a number of corn food production issues like non-forming dough, crumbly chips, and soggy cereal (Erickson, 2018). Growing Enogen requires adherence to a stewardship protocol (Syngenta, 2018), nevertheless due to the potential of Enogen contamination markets like ethanol production, grain handling and grain milling (Holdgreve, 2009) require continuous inbound testing for the Enogen GMO trait to manage the risk of contamination (Envirologix, 2022).

### Growing Enogen feed corn takes away flexibility compared to any other regular commodity corn

In addition to 30 foot physical or border rows, the stewardship protocol requires cleaning all equipment used in planting, harvest, transport, and storage. Upon harvest, all grain and/or silage must be segregated from non-Enogen corn. Moreover, the closed-loop system forces the grower to commit the crop for animal feed and prevents from selling into the commodity grain even if the market economics are favorable.

### Animal trial data is very limited on Enogen feed corn.

Note that data collected in dairy cows has little value for beef cattle, this is because intakes, as well as fiber and starch levels fed are not comparable.



To date, there are only 6 university trials reported. However, only two of those studies<sup>5,10</sup> have been published in a peer-reviewed journal. Studies have tested Enogen feed corn inclusion in beef growing calf and finishing rations as dry ground or rolled grain, high moisture grain, steam-flaked, or silage. Some trials used the corresponding isogenic counterpart (background hybrid minus the alpha-amylase transgene) or a regular hybrid as control.

1. **Schoonmaker, 2014 (Iowa State)** tested three inclusion levels (0%, 10%, 20% of diet dry matter) of Enogen as ground grain fed to 72 yearling Angus cross steers. All diets were kept identical in composition by replacing Enogen with regular ground corn at 20%, 10%, and 0% of diet dry matter. Steers were slaughtered after 131 days on feed. **No differences** were observed among treatments on growth performance or carcass characteristics. Meaning that all parameters measured (intake, ADG, feed efficiency, hot carcass weight, dressing %, LM area, marbling score, etc.) were identical. Researchers concluded that **Enogen did not have any effect** when fed at 10% nor at 20% of diet dry matter to beef steers.
2. **Jolly-Breithaupt, 2016 (U of Nebraska)** compared Enogen versus its isogenic hybrid, fed as dry rolled and high moisture corn to 384 crossbred steers for 173 days. Regardless of corn type, intakes and feed efficiency (F:G) was higher when steers were fed dry rolled grain than high moisture corn, while **no differences were observed on ADG, nor in any carcass characteristics**. Final BW was the same when steers were fed Enogen as DRC or regular HMSC, and higher than when steers were fed Enogen as HMSC or regular DRC. Overall, there were no significant effects of Enogen on steer performance nor in carcass characteristics. Researchers concluded that **results are not consistent and vary with other diet ingredients in the ration** such as corn gluten feed or DDGS.
3. **Johnson, 2018 (Kansas State)** compared feeding Enogen or regular corn as either dry rolled or whole grain to growing calves for 90 days. Calves on Enogen tended to be higher ADG (3.43 vs. 3.35 lb/d,  $p<0.09$ ), and marginally better feed efficiency (5.9 vs. 6.3,  $p<0.01$ ),

probably related to a tendency for lower intakes (20.5 vs. 21.1 lb/d,  $p<0.09$ ). However, final BW was not different between both groups (851 vs. 843 lb,  $p<0.1$ ).

4. **Johnson, 2019 (Kansas State)** looked into Enogen as silage or dry rolled grain to determine if any effect on growing calves fed for 90 day was additive. Intakes tended to be higher (20.2 vs. 20 lb/day,  $p=0.07$ ) as well as feed efficiency (6.2 vs. 6.5,  $p=0.02$ ) for calves on Enogen silage. However, final BW was not different between both groups (953 vs. 943 lb,  $p<0.1$ ). **No significant effects of corn grain type were noted over the entire trial, nor any significant interactions between corn silage type and corn grain type.**
5. **Baker, 2019 (Kansas State)** compared feeding Enogen or regular corn as either silage or steam-flaked grain to finishing steers. Intakes were 0.86 lb/day lower when steers were fed Enogen silage, **no effects on ADG, but F:G improved (5.6 vs. 5.8,  $p<0.01$ )**. However, feeding Enogen steam-flaked resulted in lower feed efficiency (5.8 vs. 5.6,  $p=0.02$ ). **Final BW was not different among groups.**
6. **Rusche, 2020 (South Dakota State)** tested Enogen silage at 12% or 24% of DM against regular corn. **Silage hybrid did not affect ADG, gain-to-feed ratio, or final BW.** Feeding 24% silage reduced ADG ( $p=0.04$ ) and increased F:G ( $p<0.01$ ). Researchers reported the **regular hybrid producing 18.5 ton/acre silage, while Enogen 17 ton/acre**, resulting in a significant difference in beef produced per acre of 119 lb (1,717 vs. 1,598 lb/acre,  $p<0.01$ ), a relevant metric for cattle feeders that grow their own forage.

In a meta-analysis of Enogen finishing trials published in 2021 (Hu et al., 2010), the authors stated that “*performance was similar for Enogen and conventional hybrids when processed and fed as high-moisture corn*”. This would suggest no value when fed as corn silage containing less mature kernels. The authors further stated that “*overall, the response of Enogen Feed Corn has been variable across studies depending on the corn processing method and byproduct utilized. In addition, studies conducted at the University of Nebraska-Lincoln (UNL) have shown small numerical improvements that were often not significant statistically*”.



# Genetic and Environmental Factors Impacting Corn Silage Fiber Digestibility

Bill Mahanna, Ph.D., Global Nutritional Sciences Manager

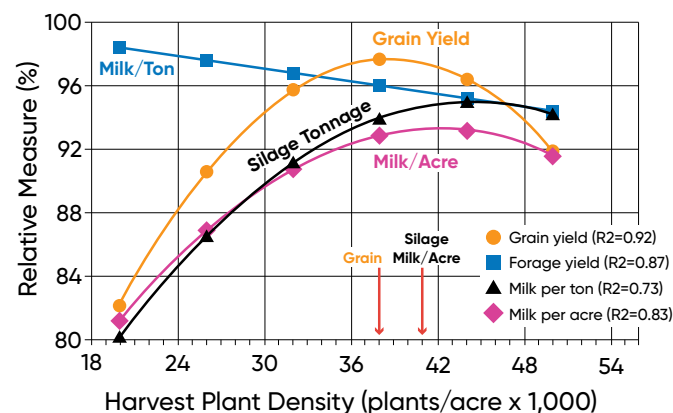
## BMR-LIKE CLAIMS

Some companies are claiming they can produce corn silage with similar fiber digestibility (NDFD) to brown midrib (BMR) by increasing stalk diameter as a result of significantly reducing plant populations as low as 24,000 plants per acre (ppa). This document will address research findings related to this theory that a standard hybrid can be manipulated to exhibit the NDFD and dry matter intake potential of BMR genetics.

## DON'T FORGET YIELD

While NDFD is certainly important to cow performance, silage yield is also a major economic driver especially on dairies with a limited land base from which to harvest and transport forages.

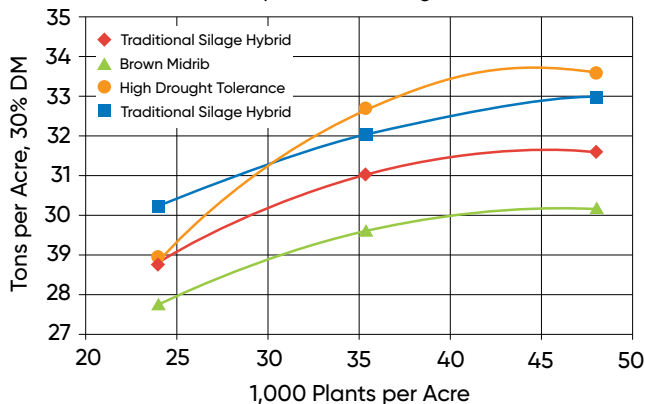
There is typically greater silage yield potential to be found through higher plant populations as documented in many university studies (Ferreira and Teets, 2017). Of course, optimum plant population varies by soil type, soil fertility, water availability, and plant genetics. Figure 1 shows results from 2000–2008 University of Wisconsin corn silage trials indicating that corn grain yield was maximized at 38,000ppa while corn silage yield was maximized at 44,000 plants per acre and corn silage milk/acre was maximized at 41,000ppa. Milk per ton was maximized at 18,000ppa but it is unlikely any dairy could sacrifice that much yield by planting at such a low population, even if planting ear-flexing hybrids.



**Figure 1.** Relationship between corn plant density and grain yield, silage yield, milk per ton and milk per acre (Lauer, 2009).

BMR silage genetics show a similar trend in terms of yield increasing with increasing plant population as demonstrated in a 2011 Pioneer research study (Figure 2).

2011 LaSalle Hybrid x Water Stress Level x Population Study (Yield x Population - Full Irrigation)



**Figure 2.** Relationship between corn hybrid planting population and silage yield (Soderlund, 2011).

## IMPACT OF PLANT POPULATION ON NDFD

Some studies have shown a small but biologically insignificant reduction in NDFD with increasing plant population. A summary of Pioneer silage hybrid studies from 2004–2007 show that 24-hour NDFD was reduced by 1–percentage point in hybrids planted from 18,000 to 42,000ppa (Jeschke and Curran, 2008, Table 1). This small decrease would have no impact on cow performance, even if corn silage was the primary forage in the diet.

**Table 1.** Effect of planting density on corn silage nutrients including 24-hour NDFD (Jeschke and Curran, 2008).

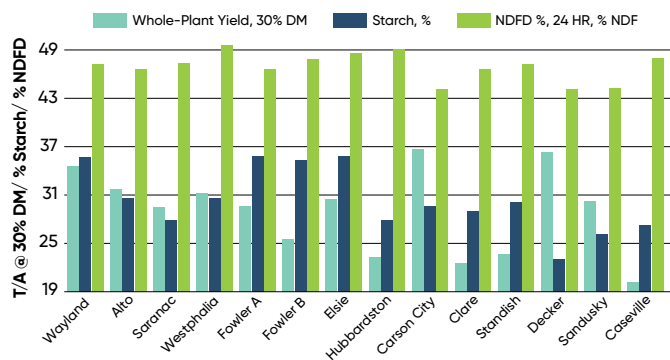
Plants/Acre	ADF	NDF	DigFib	Starch	CP
	DM Basis				
18,000	22.6	39.8	46.5	30.7	7.2
24,000	22.9	39.8	46.3	30.6	7.4
30,000	23.1	40.1	45.6	31.2	7.2
36,000	23.1	39.9	45.1	32.0	7.2
42,000	23.8	41.0	45.4	30.6	7.1

A more recent 2017 study by Ferreira and Teets (2017) examined two different standard hybrids planted in seven different fields at 55,000, 70,000, 85,000 and 100,000 plants per hectare (23,000, 29,000, 35,400, 41,600 ppa). This study demonstrated that planting density increased yield and while reducing stalk diameter (Table 2), did not significantly ( $P>0.12$ ) reduce 30-hour ruminal in vitro NDFD of the resulting silage (Table 3).

A 2-year study at the Cornell University (Aurora) Research Farm in 2008 and 2009 evaluated two Pioneer (34T55 and 34A89), two DeKalb (DKC61-69 and DKC63-42), two leafy (TMF2Q716 and 2W587, Mycogen), and two brown midrib (F2F566 and F2F610, Mycogen) hybrids at planting rates of 25,000, 30,000, 35,000, and 40,000 kernels/acre (Table 4). The researchers concluded that the DeKalb, leafy, and brown midrib hybrids had their highest yield at 35,000 kernels/acre with no real detrimental effect on NDFD and starch concentrations, whereas the Pioneer hybrids yielded best at 40,000 kernels/acre without negatively impacting NDFD (Cox et al., 2009).

### IMPACT OF GROWING ENVIRONMENT ON NDFD

The significant impact of growing environment, especially the influence of precipitation and soil water holding capacity, is well documented (Mahanna, 2010). Figure 3 illustrates the range in NDFD that one hybrid can display depending upon the unique growing environment. **It is a misrepresentation of hybrid differences for any company to compare yield, starch or NDFD of hybrids not grown in the same location.**



**Figure 3.** Yield, starch content and 24-hour NDFD of the same hybrid grown in 14 Michigan fields in 2009 (Bolinger, 2010).

**Table 2.** Effect of planting density on dry matter (DM) yield and plant structure (Ferreira and Teets, 2017).

Item	Planting density				SEM	P<		
	55K	70K	85K	100K		Trt	Linear response	Quadratic response
	plants/ha							
DM, %	32.1	31.7	31.5	31.4	0.28	0.29	0.07	0.59
Plant dry weight, g/plant	376	334	284	253	7.4	0.01	0.01	0.46
DM yield, Mg/ha	19.8	21.5	23.4	26.0	0.5	0.01	0.01	0.41
Kernel lines per ear, count	17.1	16.5	16.0	16.3	0.26	0.03	0.02	0.09
Kernels per line, count	42.2	38.9	35.6	33.9	0.69	0.01	0.01	0.25
Kernels per ear, count	720	641	570	553	13	0.01	0.01	0.03
Stem width, mm	19.7	18.9	17.4	17.0	0.32	0.01	0.01	0.64

**Table 3.** Effect of planting density on nutritional composition (DM basis) of fresh corn (Ferreira and Teets, 2017).

Item	Planting density				SEM	P<		
	55K	70K	85K	100K		Trt	Linear response	Quadratic response
	plants/ha							
Ash, %	3.5	3.7	3.7	3.7	0.07	0.17	0.11	0.14
CP, %	10.2	10.2	10.3	10.3	0.12	0.90	0.61	0.85
NDF, %	36.5	38.0	38.2	38.2	0.54	0.09	0.04	0.17
ADF, %	21.6	22.3	23.0	22.7	0.39	0.11	0.04	0.24
ADL, %	2.4	2.5	2.4	2.2	0.13	0.35	0.16	0.27
Starch, %	33.4	34.4	33.5	33.5	0.48	0.46	0.72	0.27
Sugar, %	12.3	12.4	12.7	11.5	0.34	0.15	0.15	0.07
30-h ruminal in vitro NDF digestibility %	45.9	43.9	42.4	43.8	1.08	0.12	0.12	0.14

**Table 4.** Planting rate effects on silage NDF, 30-hour NDFD, crude protein and starch of various corn hybrids averaged across 2008 and 2009 in Aurora, NY (Cox et al., 2009).

Planting Rate	Pioneer	DeKalb	Leafy	BMR	Pioneer	DeKalb	Leafy	BMR
	NDF				NDFD (30 hr)			
Kernels/acre	%				%			
25,000	39.8	39.5	40.1	41.3	58.7	58.3	58.7	71.2
30,000	40.8	39.9	41.4	41.1	59.3	57.7	59.1	72.3
35,000	40.9	39.9	40.4	41.1	57.9	57.2	59.6	72.2
40,000	41.4	40.6	42.0	42.5	59.3	57.4	59.5	73.0
Average	40.7	39.9	40.9	41.5	58.8	57.6	59.2	72.2
	CP				Starch			
25,000	8.9	8.6	8.8	8.8	33.3	34.6	34.6	33.3
30,000	8.5	8.3	8.6	8.6	34.2	34.6	34.5	32.1
35,000	8.3	8.3	8.4	8.5	33.9	34.9	34.8	32.6
40,000	8.2	8.1	8.2	8.4	33.8	34.7	34.0	31.5
Average	8.5	8.3	8.5	8.6	33.8	34.7	34.5	

# Blackleg of Canola

Kristin Hacault, Agronomy Information Consultant

## WHAT IS BLACKLEG?

- Blackleg is a serious disease of canola found in the canola growing regions of Western Canada.
- It is caused by the fungal pathogen *Leptosphaeria maculans*. A less aggressive pathogen, *Leptosphaeria biglobosa* can cause upper stem lesions but typically does not significantly affect yield.
- Infects canola from the seedling stage onward, with inoculum from previous residue/stubble. The most critical stage of infection occurs during the seedling stage.
- The disease progresses as the crops grows, eventually girdling the stem and cutting the plant off from the vital uptake of nutrients and water, leading to yield loss.
- Genetic resistance, in combination with integrated pest management strategies and proper agronomic practices, can assist in combating this disease.

## BLACKLEG LIFE CYCLE AND SYMPTOMS

- The blackleg pathogen overwinters on the previous season's crop residue.
- In spring, ascospores from the infected residue are released into the air and infect cotyledons and young leaves, forming leaf lesions.
- These leaf lesions form pycnidia that release spores (pycnidiospores). These spores mobilize (via rain splash) to further infect the plant and spread the disease to neighboring canola plants.
- As the season progresses, the original infection moves toward the base of the stem (often referred to as "basal stem canker").
- The cankering at the base of the stem cuts off water and nutrient uptake resulting in premature ripening or plant death.
- Early infections generally lead to greater yield loss. Later infections cause less damage but do contribute to the following years' soil inoculum.

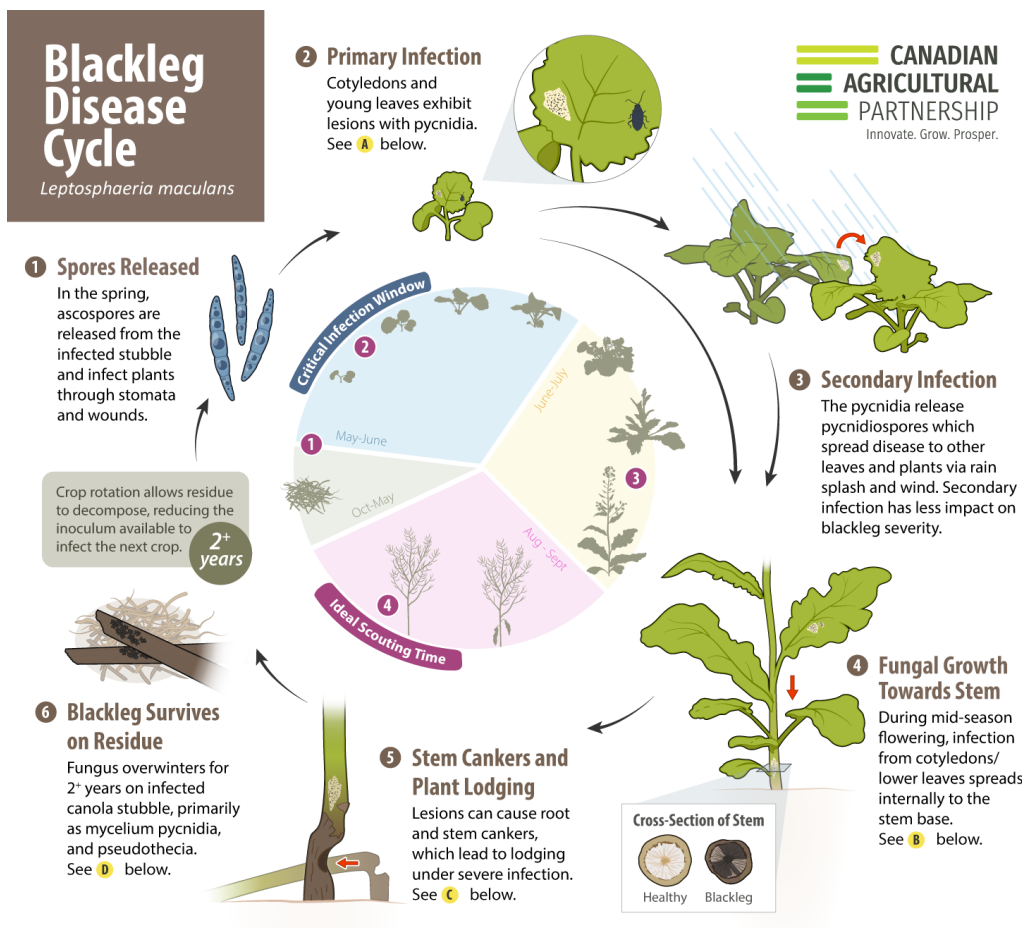


Figure 2. Blackleg leaf lesion.

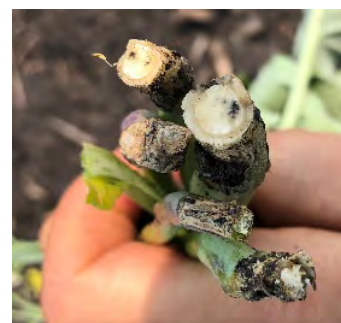


Figure 3. Stem cross section with blackleg damage.

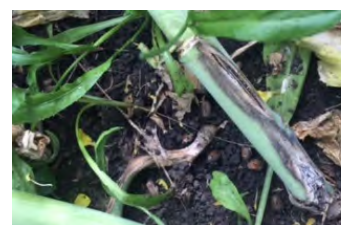


Figure 4. Root and stem cankers.

Figure 1. Blackleg disease life cycle (Photo courtesy of the Canola Council of Canada).



## BREEDING FOR GENETIC RESISTANCE

- o The Corteva Agriscience Canola Development Team uses a combination of both seedling and adult plant resistance when developing products with blackleg resistance (Table 1).







**Table 1.** Types of blackleg resistance.

	Seedling: Race Specific Resistance	Stem: Adult Plant Resistance
<b>Also known as:</b>	Major gene or qualitative resistance	Minor gene or quantitative resistance
<b>Resistance Mechanism</b>	Gene for gene or race specific. Resistance gene matches blackleg race. If other races are present, the resistance can be overcome.	Non race specific. Many genes, each with a relatively small effect, working together to provide resistance caused by any blackleg race.
<b>Location of Resistance</b>	Stem and leaves	Stem only
<b>Mode of Action</b>	Selects for corresponding races virulent for the gene	Does not select for corresponding virulent genes (less selection pressure on pathogen population)
<b>Durability of Resistance</b>	Breaks down with race shifts	Durable over time

## EVALUATING BLACKLEG RESISTANCE

- o Industry-wide testing protocols are utilized in evaluating new canola hybrids for blackleg resistance prior to commercialization.
- o Disease severity is rated using the following scale (0-5) based upon the level of diseased tissue in stem cross sections (Table 2).
- o Hybrids are then provided a rating based on their susceptibility to blackleg versus the susceptible check, Westar (Table 3).

**Table 2.** Blackleg disease severity scale.

Disease Score	0	1	2
			
<b>Level of disease of cross section</b>	No disease tissue visible	<25% disease	25-50% disease
Disease Score	3	4	5
			
<b>Level of disease of cross section</b>	51-75% disease	>75% disease, some green stem left	Stem/plant is completely dead

**Table 3.** Blackleg resistance labels.

Field Resistance Rating	% Disease Severity of Westar
R (Resistant)	0-29.9
MR (Moderately Resistant)	30-49.9
MS (Moderately Susceptible)	50-69.9
S (Susceptible)	70-100

## ON-FARM EVALUATIONS

- o The best time to assess the level of a blackleg infestation in a field is near 60% seed color change (swathing) or near harvest (straight cut).
- o Collect 50-100 plants in a W pattern at random from a field.
- o Using clippers, cut the base of the plant (stem and root intersection) and observe any black tissue.
- o Use the 0-5 scale (Table 2) to determine the severity of the field infection.

## MANAGEMENT

- o **Crop Rotation:** A minimum two-year break from canola.
- o **Scout Fields:** Scout fields regularly to determine incidence (number of plants infected) and severity (proportion of the plant tissue infected).
- o A registered fungicide application may be warranted under high disease pressure. These applications will suppress the infection but will not cure the disease. Generally, these can be applied from the two to six leaf stage. Consult individual product labels for best practices.
- o **Seed Treatment:** The LumiGEN® canola disease package, including Lumiscend™ fungicide seed treatment, provides industry-leading protection of airborne blackleg.
- o **Hybrid Selection:** Choose canola hybrids with the best overall agronomic package for your farming needs with an R blackleg rating.

# REFERENCES

- Abatzoglou, J.T., and C.A. Kolden. 2013. Relationships between climate and macroscale area burned in the western United States. *Int. J. of Wildland Fire*. 22:1003-1020. <https://www.publish.csiro.au/wf/WF13019>
- Agrios, G.N. 1988. How plants defend themselves against pathogens. 97-115. In *Plant Pathology, third edition*. Academic Press, Inc. San Diego, CA.
- Aguirre-von-Wobeser, E., J. Rocha-Estrada, L.R. Shapiro, and M. de la Torre. 2018. Enrichment of *Verrucomicrobia*, *Actinobacteria* and *Burkholderiales* drives selection of bacterial community from soil by maize roots in a traditional milpa agroecosystem. *PLoS One* 13:e0208852.
- Allen, R.G., L.S. Pereira, D. Raes, and M. Smith. 1998. Crop evapotranspiration - Guidelines for computing crop water requirements. FAO Irrigation and Drainage Paper 56. Food and Agriculture Organization of the United Nations. <http://www.fao.org/3/x0490e/x0490e00.htm#Contents>
- Anderson, N.R., M.D. Lrizarry, C.A. Bloomingdale, D.L. Smith, C.A. Bradley, D.P. Delaney, N.M. Kleczewski, E.J. Sikora, D.S. Mueller, and K.A. Wise. 2017. Effect of soybean vein necrosis on yield and seed quality of soybean. *Can J Plant Pathol* 39:334-341.
- Anderson, W. 2021. ENSO as a climate conductor for global crop yields. NOAA Climate.gov ENSO Blog. July 22, 2021. Accessed 2023-09-29.
- Arshad, M., and W.T. Frankenberger. 1991. Microbial production of plant hormones D.L. Keister, P.B. Cregan (Eds.), *The Rhizosphere and Plant Growth*. Kluwer Academic Publishers. Dordrecht, The Netherlands. pp. 327-334
- Assefa, Y., P. Carter, M. Hinds, G. Bhalla, R. Schon, M. Jeschke, S. Paszkiewicz, S. Smith, and I.A. Ciampitti. 2018. Analysis of long term study indicates both agronomic optimal plant density and increase maize yield per plant contributed to yield gain. *Scientific Reports* 8, 4937. <https://www.nature.com/articles/s41598-018-23362-x>
- Aylor, D.E., N.P. Schultes, and E.J. Shields. 2003. An aerobiological framework for assessing cross-pollination in maize. *Agric. For. Meteorol.* 119:111-129.
- Bahroun, A., A. Jousset, M. Mrabet, R. Mhamdi, and H. Mhadhbi. 2021. Protists modulate *Fusarium* root rot suppression by beneficial bacteria. *Applied Soil Ecology*, 168, 104158.
- Bajet, N.B., B.L. Renfro, J.M. Valdez Carrasco. 1994. Control of tar spot of maize and its effect on yield. *International Journal of Pest Management*, 40:121-125.
- Baker, A., V. de Aguiar, and L. Barros. 2019. 343 Feedlot performance and carcass characteristics of steers fed diets containing steam-flaked grain and corn silage from Enogen® Feed Corn. *Journal of Animal Science*. 97(Supplement\_2):137-137.
- Bales, A.M. and A.L. Lock. 2023. Harnessing the Potential of a High Oleic Acid Soybean to Improve Milk Production Responses of High Producing Dairy Cows. in Great Lakes Regional Dairy Conference. Mt. Pleasant, MI: Michigan State University.
- Barnston, A. 2014. How ENSO leads to a cascade of global impacts. NOAA Climate.gov ENSO Blog. May 19, 2014. Accessed 2023-09-29.
- Barnston, A. 2015. With El Niño likely, what climate impacts are favored for this summer? NOAA Climate.gov ENSO Blog. May 28, 2015. Accessed 2023-09-29.
- Baum, J.A., T. Bogaert, W. Clinton, G.R. Heck, P. Feldmann, O. Ilagan, S. Johnson, G. Plaetinck, T. Muniyikwa, M. Pleau, et al. 2007. Control of coleopteran insect pests through RNA interference. *Nat. Biotechnol.* 25:1322-1326.
- Bissonnette, S. 2015. CORN DISEASE ALERT: New Fungal Leaf disease "Tar spot" *Phyllachora maydis* identified in 3 northern Illinois counties. *The Bulletin*. University of Illinois Extension. <http://bulletin.ipm.illinois.edu/?p=3423>
- Bolinger, D. 2010. Field study personal communications.
- Bonner, L.J. and H.G. Dickinson. 1990. Anther dehiscence in *Lycopersicon esculentum*. II. Water relations. *New Phytol.* 115:367-375.
- Bradley, C. 2021. Kentucky soybeans: Red crown rot observed in state. *AgFax*. <https://www.agfax.com/2021/09/25/kentucky-soybeans-red-crown-rot-observed-in-state/>
- Branson, T.F. 1976. The selection of a non-diapause strain of *Diabrotica virgifera* (Coleoptera: Chrysomelidae). *Entomologia Experimentalis et Applicata*. 19:148-154.
- Broders, K, G. Iriarte-Broders, G.C. Bergstrom, E. Byamukama, M. Chilvers, C. Cruz, F. Dalla-Lana, Z. Duray, D. Malvick, D. Mueller, P. Paul, D. Plewa, R. Raid, A.E. Robertson, C. Salgado-Salazar, D. Smith, D. Telenko, K. VanEtten, and N.M. Kleczewski. 2022. *Phyllachora* species infecting maize and other grass species in the Americas represents a complex of closely related species. *Ecology and Evolution*, 12, e8832. <https://doi.org/10.1002/ece3.8832>
- Burke, M., A. Driscoll, S. Heft-Neal, J. Xue, J. Burney, and M. Wara. 2021. The changing risk and burden of wildfire in the United States. *Proc. Nat. Acad. Sci.* 118 (2) e2011048118; DOI: 10.1073/pnas.2011048118. <https://www.pnas.org/content/118/2/e2011048118>
- Butzen, S. 2012. Best management practices for corn-after-corn production. *Pioneer Crop Insights* Vol. 22. No. 6. Corteva Agriscience. Johnston, IA.
- Butzen, S. and M. Jeschke. 2022. Micronutrients for crop production. *Pioneer Crop Insights* Vol. 32. No. 2. Corteva Agriscience. Johnston, IA.
- Byamukama, E. and F. Mathew. 2022. Fusarium Root and Crown Rot Developing in Corn. S. Dakota State Univ. Ext. <https://extension.sdstate.edu/fusarium-root-and-crown-rot-developing-corn>
- Calles-Torrez, V., P.B. Beauzay, A.H. Knudson, and J.J. Knodel. 2020. Soybean Gall Midge and White-mold Gall Midge in Soybean. North Dakota State University Extension. E2006. <https://www.ag.ndsu.edu/publications/crops/soybean-gall-midge-and-white-mold-gall-midge-in-soybean>
- Canadian Interagency Forest Fire Centre. 2023. Fire Statistics. <https://www.cifcc.ca/>
- Chalkley, D. 2010. Systematic Mycology and Microbiology Laboratory, ARS, USDA. Invasive Fungi. Tar spot of corn - *Phyllachora maydis*. <https://nt.ars-grin.gov/taxadescriptions/factsheets/pdfPrintFile.cfm?thisApp=Phyllachoramaydis>
- Costea, M., Weaver, S. E. and Tardif, F. J. 2005. The Biology of Invasive Alien Plants in Canada. 3. *Amaranthus tuberculatus* (Moq.) Sauer var. *rudis* (Sauer) Costea & Tardif. *Canadian Journal of Plant Science* 85: 507-522.
- Cox, Bill, J. Cherney and P. Atkins. 2009. Corn silage hybrids and plant populations. *Cornell Extension Bulletin - What's Cropping Up?* Vol. 20, No.2.
- Crop Protection Network. 2022. Red crown rot of soybean. <https://cropprotectionnetwork.org/encyclopedia/red-crown-rot-of-soybean>
- Cueva, S., D. Wasson, S. Raisanen, L. Martins, T. Silvestre, and A. Hristov. 2022. Lactational performance and enteric gas emission in dairy cows fed an amylase-enabled corn silage, in *Journal of Dairy Science*. p. 57-57.
- Cueva, S.F., H. Stefanoni, A. Melgar, S.E. Raisanen, C.F.A. Lage, D.E. Wasson, M.E. Fetter, A.M. Pelaez, G.W. Roth, and A.N. Hristov. 2021. Lactational performance, rumen fermentation, and enteric methane emission of dairy cows fed an amylase-enabled corn silage. *J Dairy Sci.* 104(9):9827-9841.
- Dann, E. K., B. W. Diers, and R. Hammerschmidt. 1999. Suppression of sclerotinia stem rot of soybean by lactofen herbicide treatment. *Phytopathology* 89:598-562.

- Darlington, M., J.D. Reinders, A. Sethi, A.L. Lu, P. Ramaseshadri, J.R. Fischer, C.J. Boeckman, J.S. Petrick, J.M. Roper, K.E. Narva, et al. 2022. RNAi for Western Corn Rootworm Management: Lessons Learned, Challenges, and Future Directions. *Insects* 13:57.
- Da Silva, C.R., D.E.P. Telenko, J.D. Ravellette, and S Shim. 2019. Evaluation of a fungicide programs for tar spot in corn in northwestern Indiana, 2019 (COR19-23.PPAC) in Applied Research in Field Crop Pathology for Indiana- 2019. BP-205-W Purdue University Extension. <https://extension.purdue.edu/fieldcroppathology/wp-content/uploads/2020/02/Applied-Research-in-Field-Crop-Pathology-for-Indiana-2019-BP-205-W-1.pdf>
- Diaz, F. 2020. Effects of Linoleic Fatty Acid Intake on Milk Fat Production. Dellait.
- DiFonzo, C. 2018. Attack of the Asiatic garden beetles in field crops. Michigan State Univ. Extension Field Crops. <https://www.canr.msu.edu/news/attack-of-the-asiatic-garden-beetles-in-field-crops>
- Emmert, D. 2021. Effects of reduced solar radiation on corn growth and yield. Pioneer Agronomy Research Update. Vol. 11 No. 8. Corteva Agriscience. Johnston, IA
- Emmert, D. and M. Jeschke. 2022. Effects of seed orientation at planting on corn growth. Pioneer Agronomy Research Update. Vol. 12 No. 12. Corteva Agriscience. Johnston, IA.
- Envirologix Case Study: High-Sensitivity Testing for Enogen Corn. 2022.
- Erickson, A., 2011. Comment on Docket No: APHIS-2007-0016, U.-A.a.P.H.I. Service, Editor. Corn Refiners Association <https://www.regulations.gov/document/APHIS-2007-0016-0293>.
- Fadiji, A.E., O. Galeemelwe, and O.O. Babalola. 2022. Unravelling the endophytic virome inhabiting maize plant. *Agronomy* 12:1867. <https://doi.org/10.3390/agronomy12081867>.
- Ferraretto, L.F. Silage-Specific Corn Hybrids for Dairy Cattle Diets. *Forage Focus*, 2023.
- Ferreira, G and C. Teets. 2017. Effect of planting density on yield, nutritional quality and ruminal in vitro digestibility of corn for silage grown under on-farm conditions. *P.A.S.* 33:420-425.
- Ferrero-Serrano, A., C. Cantos, and S.M. Assmann. 2019. The role of dwarfing traits in historical and modern agriculture with a focus on rice. *Cold Spring Harb. Perspect. Biol.* 11:a034645.
- Fire, A., S. Xu, M.K. Montgomery, S.A. Kostas, S.E. Driver, and C.C. Mello. 1998. Potent and specific genetic interference by double-stranded RNA in *Caenorhabditis elegans*. *Nature* 391:806-811.
- Fisher, J.R., J.J. Jackson, and A.C. Lew. 1994. Temperature and diapause development in the egg of *Diabrotica barberi* (Coleoptera: Chrysomelidae). *Environ. Entomol.* 23:464-471.
- Gaspar, A.P., D.S. Mueller, K.A. Wise, M.I. Chilvers, A.U. Tenuta, and S.P. Conley. 2017. Response of broad-spectrum and target-specific seed treatment and seeding rate on soybean seed yield, profitability, and economic risk. *Crop Sci.* 56:2251-2262.
- Gaspar, A.P., S. Mourtzinis, D. Kyle, E. Galdi, L.E. Lindsey, W.P. Hamman, E.G. Matcham, H.J. Kandel, P. Schmitz, J.D. Stanley, J.P. Schmidt, D.S. Mueller, E.D. Nafziger, J. Ross, P.R. Carter, A.J. Varenhorst, K.A. Wise, I.A. Ciampitti, W.D. Carciochi, M.I. Chilvers, B. Hauswedell, A.U. Tenuta, and S.P. Conley. 2020. Defining optimal soybean seeding rates and associated risk across North America. *Agron. J.* 112:2103-2114.
- Gaspar, A.P. 2019. Soybean seeding rate – past, present, and VRS future. *Pioneer Crop Insights*. Vol. 29 No. 1. Corteva Agriscience, Johnston, IA.
- Gaspar, A.P. and S.P. Conley. 2015. Responses of canopy reflectance, light interception, and soybean seed yield to replanting suboptimal stands. *Crop Sci.* 15:377-385.
- Gassmann, A.J., J.L. Petzold-Maxwell, E.H. Clifton, M.W. Dunbar, A.M. Hoffmann, D.A. Ingber, and R.S. Keweshan. 2014. Field-evolved resistance by western corn rootworm to multiple *Bacillus thuringiensis* toxins in transgenic maize. *Proc. Nat. Acad. Sci.* 111 (14) 5141-5146.
- Gassmann, A.J., J.L. Petzold-Maxwell, R.S. Keweshan, and M.W. Dunbar. 2011. Field-evolved resistance to Bt maize by western corn rootworm. *PLOS ONE* 6(7): e22629.
- Gassmann A.J., R.B. Shrestha, S.R.K. Jakka, M.W. Dunbar, E.H. Clifton, A.R. Paolino, D.A. Ingber, B.W. French, K.E. Masloski, J.W. Dounda, and C.R. St. Clair. 2016. Evidence of resistance to Cry34/35Ab1 corn by western corn rootworm (Coleoptera: Chrysomelidae): root injury in the field and larval survival in plant-based bioassays. *J Econ Entomol* 109: 1872– 1880 (2016).
- Gray, R. 2020. 'Four times more toxic': How wildfire smoke ages over time. *Horizon: The EU Research and Innovation Magazine*. European Commission.
- Gómez-Godínez, L.J., S.L. Fernandez-Valverde, J.C. Martínez Romero, and E. Martínez-Romero. 2018. Metatranscriptomics and nitrogen fixation from the rhizoplane of maize plantlets inoculated with a group of PGPRs. *Syst. Appl. Microbiol.* 42:517-525.
- Hallmann J, A. Quadt-Hallmann, W.F. Mahaffee, and J.W. Kloepper. 1997. Bacterial endophytes in agricultural crops. *Can J Microbiol* 43:895-914.
- Hao, J., D. Wang, and R. Hammerschmidt. 2010. Using biological agents to control soybean white mold. 2010 Michigan Soybean Checkoff.
- Haridim, P.R., L.S. van Overbeek, G. Berg, A.M. Pirttilä, S. Compant, A. Campisano, M. Döring, A. Sessitsch. 2015. The hidden world within plants: ecological and evolutionary considerations for defining functioning of microbial endophytes. *Microbiol Mol Biol Rev* doi:10.1128/MMBR.00050-14
- Head, G.P., M.W. Carroll, S.P. Evans, D.M. Rule, A.R. Willse, T.L. Clark, N.P. Storer, R.D. Flannagan, L.W. Samuel, and L.J. Meinke. 2017. Evaluation of SmartStax and SmartStaxPRO maize against western corn rootworm and northern corn rootworm: Efficacy and resistance management. *Pest Manag. Sci.* 73:1883-1899.
- Heagle, A.S. 1989. Ozone and crop yield. *Annual Review of Phytopathology* 27:397-423.
- Hedden, P. 2003. The genes of the Green Revolution. *Trends in Genetics.* 19:5-9.
- Hemes, K.S., J. Verfaillie, and D.D. Baldocchi. 2020. Wildfire-smoke aerosols lead to increased light use efficiency among agricultural and restored wetland land uses in California's Central Valley. *Journal of Geophysical Research: Biogeosciences*, 125,e2019JG005380. <https://doi.org/10.1029/2019JG005380>
- Henkes, G.J., E. Kandeler, S. Marhan, S. Scheu, and M. Bonkowski. 2018. Interactions of mycorrhiza and protists in the rhizosphere systemically alter microbial community composition, plant shoot-to-root ratio and within-root system nitrogen allocation. *Frontiers in Environmental Science*, 6, 117.
- Heslop-Harrison, J.S., Y. Heslop-Harrison, and B.J. Reger. 1987. Anther filament extension in *Lilium*: potassium ion movement and some anatomical features. *Ann. Bot-London* 59:505-515.
- Hirasawa, T. and T.C. Hsiao. 1999. Some characteristics of reduced leaf photosynthesis at midday in maize growing in the field. *Field Crops Research* 62:53-62
- Hock J., J. Kranz, B.L. Renfro. 1995. Studies on the epidemiology of the tar spot disease complex of maize in Mexico. *Plant Pathology*, 44:490-502.
- Hodgson, E. 2018. New Soybean Pest in Iowa: Soybean Gall Midge. Iowa State University. Integrated Crop Management News. <https://crops.extension.iastate.edu/cropnews/2018/07/new-soybean-pest-iowa-soybean-gall-midge>
- Holdgreve, C., Comment on Docket No: APHIS-2007-0016, U.-A.a.P.H.I. Service, Editor. 2009. National Grain and Feed Association, the North American Export Grain Association, the North American Millers Association and the Pet Food Institute: <https://www.regulations.gov/document/APHIS-2007-0016-0271>.
- Holshouser, D.L., and J.P. Whittaker. 2002. Plant Population and Row-Spacing Effects on Early Soybean Production Systems in the Mid-Atlantic USA. *Agron. J.* 94: 603-611.

- Hu, W., M.E. Persia, and L. Kung, Jr. 2010. Short communication: in vitro ruminal fermentability of a modified corn cultivar expressing a thermotolerant alpha-amylase. *J Dairy Sci.* 93(10):4846-9.
- IPNI. 2014. IPNI Estimates of Nutrient Uptake and Removal. <http://www.ipni.net/article/IPNI-3296>
- Irwin, S. and D. Good. 2016. Forming Expectations for the 2016 U.S. Average Soybean Yield: What About El Niño? *farmdoc daily* (6):46, Department of Agricultural and Consumer Economics, University of Illinois at Urbana-Champaign, March 9, 2016.
- Jackson, S.T., and M.E. Lyford. 1999. Pollen dispersal models in quaternary plant ecology: assumptions, parameters and prescriptions. *Bot. Rev.* 65:39-75.
- Jakka, S.R.K., R.B. Shrestha, and A.J. Gassmann. 2016. Broad-spectrum resistance to *Bacillus thuringiensis* toxins by western corn rootworm (*Diabrotica virgifera virgifera*) *Sci Rep* 6, 27860.
- Jarosoz, N., B. Loubet, B. Durand, X. Foueillassar, and L. Huber. 2005. Variations in maize pollen emission and deposition in relation to microclimate. *Environ. Sci. Technol.* 39:4377-4384.
- Jeschke, M. 2018. Row width in corn grain production. *Pioneer Crop Insights* Vol. 28. No. 3. Corteva Agriscience. Johnston, IA.
- Jeschke, M. and A. Uppena. 2015. Corn leaf orientation response to plant density. *Pioneer Agronomy Research Update.* Vol 5. No. 7. Corteva Agriscience. Johnston, IA.
- Jeschke, M. and N. Lutt. 2016. Row width in soybean production. *Pioneer Crop Insights.* Vol. 26 No. 8. Corteva Agriscience, Johnston, IA.
- Jeschke, M and B. Curran. 2008. Plant population effects on corn silage yield and quality. *Pioneer Crop Insights* Vol. 18, No. 8.
- Johnson, M., T. Spore, S. Montgomery, W. Hollenbeck, R. Wahl, E. Watson, and D. Blasi. 2020. Syngenta Enogen Feed Corn silage containing an alpha amylase expression trait improves feed efficiency in growing calf diets. *Cattlemen's Day, Kansas Agricultural Experiment Station Research Reports.* New Prairie Press, Kansas State University. 6(2):31-34.
- Johnson, M.A., T. Spore, S.P. Montgomery, W.R. Hollenbeck, R.N. Wahl, E.D. Watson, and D.A. Blasi. 2019. Syngenta Enogen Feed Corn Silage Containing an Alpha Amylase Expression Trait Improves Feed Efficiency in Growing Calf Diets. *Kansas Agricultural Experiment Station Research Reports.* 5(1).
- Jolly-Breithaupt, M.L., C.J. Bittner, D. Burken Burken, G.E. Erickson, J.C. MacDonald, and M.K. Luebke. 2016. Evaluating syngenta enhanced feed corn processed as dry-rolled or high-moisture corn on cattle performance and carcass characteristics. *Beef Cattle Reports.* 139-142. University of Nebraska-Lincoln.
- Joyce, A. and L. Thiessen. 2020. Red crown rot of soybean. *North Carolina State Univ. Extension Publications.* <https://content.ces.ncsu.edu/red-crown-rot-of-soybean>
- Keough, S., J. Han, T. Shuman, K. Wise, and P. Nachappa. 2016. Effects of Soybean vein necrosis virus on life history and host preference of its vector, *Neohydatothrips variabilis*, and evaluation of vector status of *Frankliniella tritici* and *F. fusca*. *J. Econ. Entomol.* 109:1979-1987.
- Kiesselbach, T.A. 1999. *The Structure and Reproduction of Corn*, 50th Anniversary Edition. Cold Spring Harbor Press, New York.
- Kitchen, N., S. Stewart, L. Conway, M. Yost, and P. Carter. 2021. How planting depth and soil texture affect corn emergence. *Pioneer Agronomy Research Update.* Vol. 11 No. 5. Corteva Agriscience. Johnston, IA.
- Kleczewski, N., M. Chilvers, D. Mueller, D. Plewa, A. Robertson, D. Smith, and D. Telenko. 2019. Tar Spot. *Corn Disease Management CPN-2012.* Crop Protection Network.
- Kleczewski, N. 2019. What do low tar spot disease levels and prevent plant acres mean for 2020 corn crop? *Illinois Field Crop Disease Hub.* University of Illinois Extension. <http://cropdisease.cropsciences.illinois.edu/?p=992>
- Kleczewski, N. 2020. Red crown rot: What to look for in your soybean fields. *Illinois Field Crop Disease Hub.* Univ. of Illinois Extension. <http://cropdisease.cropsciences.illinois.edu/?p=1220>
- Kleczewski, N. and D. Smith. 2018. Corn Hybrid Response to Tar Spot. *The Bulletin.* University of Illinois Extension. <http://bulletin.ipm.illinois.edu/?p=4341>
- Knodel, J.J. 2019. Soybean Gall Midge (07/25/19). *Crop & Pest Report.* North Dakota State University. <https://www.ag.ndsu.edu/cpr/entomology/soybean-gall-midge-07-25-19>
- Koch, B., J. Kurlle, D. Malvick, and B. Potter. 2019. Soybean gall midge not only small orange fly larvae in Minnesota soybean fields: Another species associated with white mold. *Minnesota Crop News.* University of Minnesota Extension. <https://blog-crop-news.extension.umn.edu/2019/10/soybean-gall-midge-not-only-small.html>
- Korres, N.E., J.K. Norsworthy, A. Mauromoustakos, and M.M. Williams II. 2020. Soybean density and Palmer amaranth (*Amaranthus palmeri*) establishment time: effects on weed biology, crop yield, and economic returns. *Weed Sci.* 68:467-475.
- Krogstad, K.C. and B.J. Bradford. 2022 The effects of early postharvest feeding of  $\alpha$ -amylase enhanced corn silage and different starch concentrations on milk production and blood metabolites of Holstein cows. *Journal of Dairy Science.* p. 68.
- Krysan, J.L. 1978. Diapause, quiescence, and moisture in the egg of the western corn rootworm, *Diabrotica virgifera*. *J Insect Physiol.* 24:535-540.
- Krysan, J.L. 1982. Diapause in the nearctic species of the *virgifera* group of *Diabrotica*: evidence for tropical origin and temperate adaptations. *Annals of the Entomol. Soc. of Am.* 75:136-142.
- Kyle, D. 2014. Effect of Cobra® herbicide on soybean yield in the absence of white mold or weed pressure. *Pioneer Agronomy Research Update.* Vol. 4 No. 36. Corteva Agriscience. Johnston, IA.
- Latshaw, W.L., and E.C. Miller. 1924. Elemental composition of the corn plant. *Journal of Agricultural Research* 27:845-860.
- Lauer, J. 2009. University of Wisconsin Agronomy Advice. *Field Crops* 28:424-62.
- Lee, C.D., D.B. Egli, and D.M. TeKrony. 2008. Soybean response to plant population at early and late planting dates in the Mid-South. *Agron. J.* 100:971-976.
- Lee, C.D., K.A. Renner, D. Penner, R. Hammerschmidt, and J.D. Kelly. 2005. Glyphosate-resistant soybean management system effect on Sclerotinia stem rot. *Weed Technol.* 19:580-588.
- Levine, E., H. Oloumi-Sadeghi, and J.R. Fisher. 1992. Discovery of multiyear diapauses in Illinois and South Dakota northern corn rootworm (Coleoptera: Chrysomelidae) eggs and incidence of the prolonged diapauses trait in Illinois. *J. Econ. Entomol.* 85:262-267.
- Lindsey, A., and P. Thomison. 2020. Corn planting depth: Soil temperature and moisture flux in the furrow. *Pioneer Agronomy Research Update.* Vol. 10 No. 3. Corteva Agriscience. Johnston, IA.
- Lindsey, A., L. Lindsey, and A. Wilson. 2021. Hazy days...How does light influence corn and soybean? *C.O.R.N. Newsletter.* Ohio State University Extension. <https://agcrops.osu.edu/newsletter/corn-newsletter/2021-26/hazy-days%E2%80%A6how-does-light-influence-corn-and-soybean>
- Lindsey, R. 2016. Global impacts of El Niño and La Niña. *NOAA Climate.gov.* February 9, 2016. Accessed 2023-09-29.
- Liu, W. and M. Tollenaar, 2009. Physiological mechanisms underlying heterosis for shade tolerance in maize. *Crop Sci.* 49:1817-1826.
- Lobell, D.B., G.L. Hammer, G. McLean, C. Messina, M.J. Roberts, and W. Schlenker. 2013. The critical role of extreme heat for maize production in the United States. *Nature Climate Change* 3:497-501.
- Lobell, D.B. and J.A. Burney. 2021. Cleaner air has contributed one-fifth of US maize and soybean yield gains since 1999. *Environ. Res. Lett.* 16:074049.
- Londo, A., A. Lindsey, L. Lindsey, H. Lopez-Nicora, and W. Novais. 2023. Smoke from Wildfires Affecting Ohio Agriculture? Or Some Other Stressors? *C.O.R.N. Newsletter.* Ohio State University Extension. <https://agcrops.osu.edu/newsletter/corn-newsletter/2023-22/smoke-wildfires-affecting-ohio-agriculture-or-some-other>

- Lopes, J.C., et al. 2017. Effect of High-Oleic-Acid Soybeans on Production Performance, Milk Fatty Acid Composition, and Enteric Methane Emission in Dairy Cows. *J Dairy Sci.* 100(2): p. 1122-1135.
- Lutt, N., D. Berning, and S. Endicott. 2016. Corn management in high pH soils. *Pioneer Field Facts Vol. 16 No. 14.* Corteva Agriscience, Johnston, IA.
- L'Heureux, M. 2014. What is the El Niño–Southern Oscillation (ENSO) in a nutshell? NOAA Climate.gov ENSO Blog. May 5, 2014. Accessed 2023-09-29.
- Maarastawi, S.A., K. Frindte, M. Linnartz, and C. Knief. 2018. Crop rotation and straw application impact microbial communities in Italian and Philippine soils and the rhizosphere of *Zea mays*. *Front. Microbiol.* 9:1295.
- Mackellar, B. and C. DiFonzo. 2018. Asiatic garden beetles may cause corn yield losses. *Morning Ag Clips.* <https://www.morningagclips.com/asiatic-garden-beetles-may-cause-corn-yield-losses/>
- Maddonni, G.A., M.E. Otegui, B. Andrieu, M. Chelle, and J.J. Casal. 2002. Maize leaves turn away from neighbors. *Plant Physiol.* 130:1181-1189.
- Mahanna, B. 2010. Growing conditions affect silage quality. *Fedstuffs.* Vol. 82, No. 24.
- Malvick, D. 2019. Tar spot of corn found for the first time in Minnesota. *Minnesota Crop News.* October 1, 2019. University of Minnesota Extension. <https://blog-crop-news.extension.umn.edu/2019/10/tar-spot-of-corn-found-for-first-time.html>
- Mander, C., S. Wakelin, S. Young, L. Condron, and M. O'Callaghan. 2012. Incidence and diversity of phosphate-solubilising bacteria are linked to phosphorus status in grassland soils. *Soil Biol. Biochem.* 44:93-101.
- McGrath, J.M., A.M. Betzelberger, S. Wang, E. Shook, X. Zhu, S.P. Long, and E.A. Ainsworth. 2015. An analysis of ozone damage to historical maize and soybean yields in the United States. *Proc. Nat. Acad. Sci.* 112:14390-14395. <https://doi.org/10.1073/pnas.1509777112>
- McMechan, A.J., E.W. Hodgson, A.J. Varenhorst, T. Hunt, R. Wright, and B. Potter. 2021c. Soybean gall midge (Diptera: Cecidomyiidae), a new species causing injury to soybean in the United States. *J. of Integrated Pest Management.* 12(1): 8,1-4.
- McMechan, J., R. Wright, T. Hunt, and A. Nygren. 2018. Orange Gall Midge in Soybeans. University of Nebraska–Lincoln Crop Watch. <https://cropwatch.unl.edu/2018/orange-gall-midge-soybeans>
- McMechan, J., T. Hunt, E. Hodgson, B. Potter, B. Koch, B. Wright, and V. Montenegro. 2021a. Midwest Soybean Gall Midge Discussion Series Session #2: Soybean Gall Midge Ecology and Plant Injury. <https://soybeangallmidge.org/soybean-gall-midge-series-videos>
- McMechan, J., T. Hunt, E. Hodgson, B. Potter, R. Koch, R. Wright, and V. Montenegro. 2021b. Midwest Soybean Gall Midge Discussion Series Session #3: Management: What We Know and The Challenges We Face. <https://soybeangallmidge.org/soybean-gall-midge-series-videos>
- McMechan, J. 2018. Soybean Gall Midge: Adult Stage Identified. University of Nebraska–Lincoln Crop Watch. <https://cropwatch.unl.edu/2018/soybean-gall-midge-adult-stage-identified>
- McMechan, J. 2019. Mid-Season Update on Soybean Gall Midge. University of Nebraska–Lincoln Crop Watch. <https://cropwatch.unl.edu/2019/mid-season-update-soybean-gall-midge>
- Mesick, H., and M. Jeschke. 2014. Corn leaf architecture response to plant density. *Pioneer Agronomy Research Update.* Vol 4. No. 14. Corteva Agriscience, Johnston, IA.
- Miller, C. 2016. Tar spot of corn detected for the first time in Florida. University of Florida Extension. [http://discover.pbcgov.org/coextension/agriculture/pdf/Tar Spot of Corn.pdf](http://discover.pbcgov.org/coextension/agriculture/pdf/Tar%20Spot%20of%20Corn.pdf).
- Montgomery J. S., Sadeque A., Giacomini D.A., Brown P.J. and Tranel P.J. 2019. Sex-specific markers for waterhemp (*Amaranthus tuberculatus*) and Palmer amaranth (*Amaranthus palmeri*). *Weed Sci* 67:412-418.
- Mottaleb, K.A., A. Loladze, K. Sonder, G. Kruseman, and F. San Vicente. 2018. Threats of tar spot complex disease of maize in the United States of America and its global consequences. *Mitigation and Adaptation Strategies for Global Change.* Online May 3, 2018: <https://link.springer.com/article/10.1007/s11027-018-9812-1>
- Mueller, D., C. Bradley, M. Chilvers, P. Esker, D. Malvick, A. Peltier, A. Sisson, and K. Wise. 2015. White Mold. Soybean Disease Management CPN-1005. Crop Protection Network.
- NASA. 2017. Wildfire smoke crosses U.S. on the jet stream. *Global Climate Change News.* Sept 6, 2017. <https://climate.nasa.gov/news/2624/wildfire-smoke-crosses-us-on-the-jet-stream/>
- National Interagency Fire Center. 2021. National Interagency Fire Center Wildland Fire Statistics. [https://www.nifc.gov/fireInfo/fireInfo\\_statistics.html](https://www.nifc.gov/fireInfo/fireInfo_statistics.html) Accessed August 4, 2021.
- Nelson, K. A., K. A. Renner, and R. Hammerschmidt. 2001. Effects of protoporphyrinogen oxidase inhibitors on soybean (*Glycine max* L.) response, Sclerotinia sclerotium disease development, and phytoalexin production by soybean. *Weed Technology* 16:353-359.
- Nelson, K. A., K. A. Renner, and R. Hammerschmidt. 2002. Cultivar and herbicide selection affects soybean development and the incidence of Sclerotinia Stem Rot. *Agron. J.* 94:1270-1281.
- Nguyen B.T., K. Dumack, P. Trivedi, Z. Islam, and H.W. Hu. 2023. Plant associated protists–Untapped promising candidates for agrifood tools. *Environ Microbiol.* 25:229-240. doi: 10.1111/1462-2920.16303.
- Nielsen, R. 2018. Tassel Emergence & Pollen Shed. *Purdue University Extension Entomology, Pest & Crop Newsletter.*
- Nielsen, R. 2020. Do Your Ears Hang Low? (Premature Ear Declination in Corn) *Corny News Network.* Purdue Univ. Extension. <http://www.kingcorn.org/news/timeless/Droopy.html>.
- Nielsen, R.L. 2019. The "Zipper" Pattern of Poor Kernel Set in Corn. *Corny News Network.* Purdue University Extension. <http://www.kingcorn.org/news/timeless/Zipper.html>
- NOAA. 2023. National Ocean Service website. <https://oceanservice.noaa.gov/facts/ninonina.html>. Accessed 2023-09-29.
- NOAA 2023. National Weather Service Climate Prediction Center. Cold & Warm Episodes by Season. [https://origin.cpc.ncep.noaa.gov/products/analysis\\_monitoring/ensostuff/ONI\\_v5.php](https://origin.cpc.ncep.noaa.gov/products/analysis_monitoring/ensostuff/ONI_v5.php). Accessed 2023-09-29.
- Obayes, S.K., L. Timber, M. Head, and E.E. Sparks. 2022. Evaluation of brace root parameters and its effect on the stiffness of maize, in silico plants. 4: diac008.
- Okello, P.N., K. Petrovic, B. Kontz, and F.M. Mathew. 2019. Eight Species of *Fusarium* Cause Root Rot of Corn (*Zea mays*) in South Dakota. *Plant Health Progress.* 20:38-43.
- Oplinger, E.S., C.R. Grau, J.E. Kurlle, J.M. Gaska, and N. Kurtzweil. 1999. Foliar treatments for control of white mold in soybean. University of Wisconsin-Madison.
- Overpeck, J.T., and B. Udall. 2020. Climate change and the aridification of North America. *Proc. Nat. Acad. Sci.* 117:11856-11858.
- Overton, T.R. Feeding for High Components in Herd Health and Nutrition Conference. 2017. Liverpool, NY: PRO-DAIRY, Cornell University.
- Parker, A., K. Fry and K. Reese. 2016. Planting date effect on soybean reproductive duration. *Pioneer Agronomy Research Update Vol. 6 No. 2.* Corteva Agriscience, Johnston, IA.
- Pascual, J.A., M. Ros, J. Martínez, F. Carmona, A. Bernabé, R. Torres, T. Lucena, R. Aznar, D.R. Arahaj, and F. Fernández. 2020. *Methylobacterium symbioticum* sp. nov., a new species isolated from spores of *Glomus iranicum* var. *tenuihypharum*. *Curr Microbiol.* 2020 77:2031-2041. doi: 10.1007/s00284-020-02101-4.
- Paszkiwicz, S.R., D. Ellerman, and K. Schrader. 2005. Corn seed planting orientation and plant population influence on physiological responses and grain yield. *ASA-CSSA-SSSA International Annual Meetings* 58:816a.
- Patten, G.P., and D.M. Van Doren, Jr. 1970. Effect of seed orientation on emergence and growth of corn. *Agron. J.* 62:592-595.
- Pedersen, P. 2009. Soybean growth and development. Iowa State University Extension.

- Pekarcik, A. 2018. Asiatic Garden Beetle: A Continuing Problem in Northern Ohio. Ohio State Univ. C.O.R.N. Newsletter. <https://agcrops.osu.edu/newsletter/corn-newsletter/2018-15/asiatic-garden-beetle-continuing-problem-northern-ohio>
- Peltier, A., S. Naeve, and D. Kaiser. 2023. Strategic Farming: Let's talk crops! session talks biologicals on corn and soybean. Minnesota Crop News. Univ. of Minnesota Extension.
- Peters, D.B., and J.T. Woolley. 1959. Orientation corn planting saves moisture. *Crops and Soils*. 11 (8):22.
- Prein, A.F. 2023. Thunderstorm straight line winds intensify with climate change. *Nature Climate Change*. Nov 2:1-7.
- Propheter, J. and M. Jeschke. 2017. High yield soybean production in the Western Corn Belt. *Pioneer Crop Insights* Vol. 27 No. 5. Corteva Agriscience, Johnston, IA.
- Pérez-Invernón, F.J., F.J. Gordillo-Vázquez, H. Huntrieser, and P. Jöckel. 2023. Variation of lightning-ignited wildfire patterns under climate change. *Nature Communications*. 14:739.
- Quiroga G.,G. Erice, R. Aroca, F. Chaumont, and J.M. Ruiz-Lozano. 2017. Enhanced drought stress tolerance by the arbuscular mycorrhizal symbiosis in a drought-sensitive maize cultivar is related to a broader and differential regulation of host plant aquaporins than in a drought-tolerant cultivar. *Front. Plant Sci*. 8:1056. doi: 10.3389/fpls.2017.01056
- Rasmussen A., L. Erndwein, A. Stager, J.W. Reneau, and E.E. Sparks. Preprint. Bigger is better: Thicker maize brace roots are advantageous for both strength and nitrogen uptake. *bioRxiv*, 2022. <https://doi.org/10.1101/2022.10.01.510439>
- Rebello, L.R., M.L. Eastridge, J.L. Firkins, and C. Lee. 2023. Effects of corn silage and grain expressing alpha-amylase on ruminal nutrient digestibility, microbial protein synthesis, and enteric methane emissions in lactating cows. *J Dairy Sci*. 106(6):3932-3946.
- Reed, A., G. Singletary, J. Schussler, D. Williamson and A. Christy, 1988. Shading effects on dry matter and nitrogen partitioning, kernel number, and yield of maize. *Crop Sci*. 28:819-825.
- Reneau, J.W., R.S. Khangura, A. Stager, L. Erndwein, T. Weldekidan, D.D. Cook, B.P. Dilkes, and E.E. Sparks. 2020. Maize brace roots provide stalk anchorage. *Plant Direct* 4:e00284.
- Roberts, M.J., W. Schlenker, and J. Eyer. 2013. Agronomic weather measures in econometric models of crop yield with implications for climate change. *Am. J. Agricult. Econom.* 95:236-243.
- Robertson, A., K. Wise, and T.A. Jackson-Ziems. 2023. Frequently asked Questions about Crown Rot in Corn. *Crop Protection Network CPN-2020*. DOI: [doi.org/10.31274/cpn-20230307-0](https://doi.org/10.31274/cpn-20230307-0)
- Roesch, L.F.W., R.R. Fulthorpe, A. Riva, G. Casella, A.K.M. Hadwin, A.D. Kent, S.H. Daroub, F.A.O. Camargo, W.G. Farmerie, and E.W. Triplett. 2007. Pyrosequencing enumerates and contrasts soil microbial diversity. *IMSE J*. 1:283-290.
- Ross, T.J., M.I. Chilvers, A. Byrne, D.L. Smith, B. Mueller, S. Shim, and D.E.P. Telenko. 2023. Integration of disease tolerance and fungicide application for management of tar spot on hybrid corn in North Central United States. *Plant Health Prog*. doi.org/10.1094/PHP-10-22-0103-RS.
- Rossinck, M.J. 2015a. Plants, viruses and the environment: Ecology and mutualism. *Virology*. 479:271-277.
- Rossinck, M.J. 2015b. Move over, bacteria! Viruses make their mark as mutualistic microbial symbionts. *J. Virol*. 89:6532-6535.
- Ruhl G., M.K. Romberg, S. Bissonnette, D. Plewa, T. Creswell, and K.A. Wise 2016. First report of tar spot on corn caused by *Phyllachora maydis* in the United States. *Plant Dis* 100(7):1496.
- Rusche, W.C., J.A. Walker, and Z.K. Smith. 2020. Effect of inclusion rate of silage with or without alpha-amylase trait on finishing steer growth performance, carcass characteristics, and agronomic efficiency measures. *Transl Anim Sci*. 4(2).
- Salisbury, F. B. and C. W. Ross. 1978. *Plant Physiology*. 2nd Ed. Wadsworth Publishing Co., Belmont, CA. pp. 123-159.
- Saravanakumar, K., L. Fan, K. Fu, C. Yu, M. Wang, H. Xia, J. Sun, Y. Li, and J. Chen. 2016. Cellulase from *Trichoderma harzianum* interacts with roots and triggers induced systemic resistance to foliar disease in maize. *Sci. Rep*. 6:35543.
- Schoonmaker, J., M. Persia, and D. Beitz. 2014. Effect of feeding corn modified to contain a unique amylase on performance and carcass characteristics of feedlot steers. *The Professional Animal Scientist*. 30(5):561-565.
- Scordo, F., S. Chandra, E. Suenaga, S.J. Kelson, J. Culpepper, L. Scaff, F. Tromboni, T.J. Caldwell, C. Seitz, J.E. Fiorenza, C.E. Williamson, S. Sadro, K.C. Rose, and S.R. Poulson. 2021. Smoke from regional wildfires alters lake ecology. *Nature Scientific Reports*. 11:10922. <https://doi.org/10.1038/s41598-021-89926-6>
- Sever, M. 2021. Soybean Gall Midge: How Do You Solve a Problem You Know Little About? *Crops & Soils Magazine*. American Society of Agronomy.
- Shi, T.Q., H. Peng, S.Y. Zeng, R.Y. Ji, K. Shi, H. Huang, and X.J. Ji. 2017. Microbial production of plant hormones: Opportunities and challenges. *Bioengineered*. 8:124-128.
- Singh, R. and S.B. Goodwin. 2022. Exploring the corn microbiome: A detailed review on current knowledge, techniques, and future directions. *Phytofrontiers*. 2:158-175.
- Skelly, P.E. 2013. Featured Creatures: The Asiatic Garden Beetle. Univ. of Florida Entomology and Nematology. [http://entnemdept.ufl.edu/creatures/ORN/TURF/asiatic\\_garden\\_beetle.htm](http://entnemdept.ufl.edu/creatures/ORN/TURF/asiatic_garden_beetle.htm)
- Smith, D., S. Chapman, and B. Mueller. 2016. Wisconsin Field Crops Pathology Fungicide Tests Summary. Univ. of Wisconsin Extension.
- Smith, S.E., and D.J. Read. 2008. *Mycorrhizal Symbiosis*, 3rd ed. Elsevier Academic Press Inc, San Diego, CA.
- Soderlund, S., F. N. Owens and C. Fagan. 2013. Field experience with drought-tolerant corn. Presentation given at the Joint Annual Meeting of the American Dairy Science Association (ADSA) and American Society of Animal Science (ASAS), Indianapolis, Indiana, July 2013.
- Sparks, E.E. 2023. Maize plants and the brace roots that support them. *New Phytologist*. 237: 48-52.
- Stephens, S.L., B.M. Collins, C.J. Fettig, M.A. Finney, C.M. Hoffman, E.E. Knapp, M.P. North, H. Safford, and R.B. Wayman. 2018. Drought, tree mortality, and wildfire in forests adapted to frequent fire. *BioScience* 68:77-88. <https://academic.oup.com/bioscience/article/68/2/77/4797261>
- Strachan, S. 2022. Timing of pollen shed in corn. *Pioneer Agronomy Research Update*. Vol. 12, No. 11. Corteva Agriscience. Johnston, IA.
- Suhre, J.J., N.H. Weidenbenner, S.C. Rowntree, E.W. Wilson, S.L. Naeve, S.P. Conley, S.N. Casteel, B.W. Diers, P.D. Esker, J.E. Specht, and V.M. Davis. 2014. Soybean yield partitioning changes revealed by genetic gain and seeding rate interactions. *Agron. J*. 106:1631-1642.
- Syngenta Enogen Stewardship Guide. 2018.
- Taylor, M., A. Nygren, and J. Rees. 2023. Drooping Corn Ears Across Nebraska. *CropWatch*. Univ. of Nebraska-Lincoln. <https://cropwatch.unl.edu/2020/drooping-corn-ears-across-nebraska>
- Telenko, D., M.I. Chilvers, N. Kleczewski, D.L. Smith, A.M. Byrne, P. Devillez, T. Diallo, R. Higgins, D. Joos, K. Kohn, J. Lauer, B. Mueller, M.P. Singh, W.D. Widdicombe, and L.A. Williams. 2019. How tar spot of corn impacted hybrid yields during the 2018 Midwest epidemic. *Crop Protection Network*. <https://cropprotectionnetwork.org/resources/features/how-tar-spot-of-corn-impacted-hybrid-yields-during-the-2018-midwest-epidemic>
- Telenko, D.E.P., M.I. Chilvers, A.M. Byrne, J.C. Check, C.R. Da Silva, N.M. Kleczewski, E. Roggenkamp, T.J. Ross, and D.L. Smith. 2022. Fungicide efficacy on tar spot and yield of corn in the Midwestern United States. *Plant Health Prog*. doi.org/10.1094/PHP-10-21-0125-RS.
- Tidwell, T. 2010. Thinking like a mountain, about fire. Speech at the Big Burn Centennial Commemoration, May 22, 2010. Forest Service U.S. Dept. of Agriculture. <https://www.fs.usda.gov/speeches/thinking-mountain-about-fire>

- Torres, G.M., A. Koller, R. Taylor, and W.R. Raun. 2017. Seed-oriented planting improves light interception, radiation use efficiency, and grain yield of maize (*Zea mays* L.). *Experimental Agriculture* 53:210-225.
- Torres, G.M., J. Vossenkemper, W. Raun, and R Taylor. 2011. Maize (*Zea mays*) leaf angle and emergence as affected by seed orientation at planting. *Experimental Agriculture*. 47:579-592.
- Trybom, J, M. Jeschke, and S. Butzen. 2009. Seed treatment effects on stand establishment and yield in soybeans. *Pioneer Field Facts* Vol. 9 No. 2. Corteva Agriscience, Johnston, IA.
- Trybom, J. 2009. Effect of seeding rate, seed treatment, and planting date on soybean performance. *Pioneer Field Facts* Vol. 9 No. 4. Corteva Agriscience, Johnston, IA.
- Tylka, G.L. 2022. High Reproduction of SCN Populations on PI 88788 Resistance is Frightening, Iowa State University, ICM online newsletter.
- Tzanetakis, I., R. Wen, M. Newman, and R. Hajimorad. 2009. Soybean vein necrosis virus: A new threat to soybean production in Southeastern United States? *Phytopathology* 99:S131.
- United Soybean Board. 2017. Take Action: Waterhemp Management in Soybeans. Available from: <https://iwilltakeaction.com/resources/waterhemp-management-in-soybeans/> Accessed September 20, 2023.
- USDA-ERS. 2023. Recent U.S. soybean production costs and returns. Retrieved from [www.ers.usda.gov](http://www.ers.usda.gov) (accessed January 12, 2023).
- USDA Agricultural Research Service. 2016. Effects of ozone air pollution on plants. <https://www.ars.usda.gov/southeast-area/raleigh-nc/plant-science-research/docs/climate-changeair-quality-laboratory/ozone-effects-on-plants/>
- USDA National Agriculture Statistics Service. 2023. NASS - Quick Stats. USDA National Agricultural Statistics Service. <https://data.nal.usda.gov/dataset/nass-quick-stats>. Accessed 2023-09-29.
- Valle-Torres J., Ross T.J., Plewa D., Avellaneda M.C., Check J., Chilvers M.I., Cruz A.P., Dalla Lana F., Groves C., Gongora-Canul C., Henriquez-Dole L., Jamann T., Kleczewski N., Lipps S., Malvick D., McCoy A.G., Mueller D.S., Paul P.A., Puerto C., Schloemer C., Raid R.N., Robertson A., Roggenkamp E.M., Smith D.L., Telenko D.E.P., Cruz C.D. 2020. Tar Spot: An Understudied Disease Threatening Corn Production in the Americas. *Plant Dis.* 104:2541-2550. doi: 10.1094/PDIS-02-20-0449-FE.
- Van Deynze, A., P. Zamora, P.-M. Delaux, C. Heitmann, D. Jayaraman S. Rajasekar, D. Graham, J. Maeda, D. Gibson, K.D. Schwartz et al. 2018. Nitrogen fixation in a landrace of maize is supported by a mucilage-associated diazotrophic microbiota. *PLoS Biology* 16: e2006352.
- van Hout, R., M. Chamecki, G. Brush, J. Katz, and M.B. Parlange. 2008. The influence of local meteorological conditions on the circadian rhythm of corn (*Zea mays* L.) pollen emission. *Agric. For. Meteorol.* 148:1078-1092.
- Van Roekel, R., and L. Purcell. 2016. Understanding and increasing soybean yields. *Pioneer Crop Insights*. Vol. 26 No. 7. Corteva Agriscience, Johnston, IA.
- Van Roekel, R. 2019. The importance of early planting for soybeans in the Midwest. *Pioneer Crop Focus* Vol. 11 No. 1. Corteva Agriscience, Johnston, IA.
- Varenhorst, A., A. Bachmann, P. Rozeboom, and P. Wagner. 2018. Do You Have Gall Midges in Your Soybean? South Dakota State University. <http://igrow.org/agronomy/soybeans/do-you-have-gall-midges-in-your-soybean/>
- Varenhorst, A. and C. Strunk. 2015. Gall Midge Larvae in Soybean Stems. South Dakota State University. <http://igrow.org/agronomy/soybeans/gall-midge-larvae-in-soybean-stems/>
- Vera, R.T., A.J.B. Garcia, F.J.C. Álvarez, J.M. Ruiz, and F.F. Martín. 2023. Application and effectiveness of *Methylobacterium symbioticum* as a biological inoculant in maize and strawberry crops. *Folia Microbiologica*. <https://doi.org/10.1007/s12223-023-01078-4>.
- Volk, Stacia M., Hannah C. Wilson, Kathryn J. Hanford, James C. MacDonald and Galen E. Erickson. Impact of Feeding Syngenta Enogen® Feed Corn Compared to Control Corn in Different Diet Scenarios to Finishing Beef Cattle. *Animals* 2021, <https://www.mdpi.com/journal/animals>
- Walker, P., and F.N. Owens. 2013. Effect of seed orientation on corn grain and silage yield. *Pioneer Agronomy Research Update*. Vol. 3 No. 42. Corteva Agriscience. Johnston, IA.
- Wallace, J.G., K.A. Kremling, L.L. Kovar, and E.S. Buckler. 2018. Quantitative genetics of the maize leaf microbiome. *Phytobiomes J.* 2:208-224.
- Webster, R.W., M.G. Roth, B.D. Mueller, D.S. Mueller, M.I. Chilvers, J.F. Willbur, S. Mourtzinis, S.P. Conley, and D.L. Smith. 2022. Integration of row spacing, seeding rates, and fungicide applications for control of sclerotinia stem rot in *Glycine max*. *Plant Disease*. 106:1183-1191.
- Weld, K. and L. Armentano, Feeding High Oleic Acid Soybeans in Place of Conventional Soybeans Increases Milk Fat Concentration. *J Dairy Sci*, 2018. 101(11): p. 9768-9776.
- Westgate, M. and R. Vittetoe. 2017. Addressing the Edge or Border Effect on Corn Yields. *Integrated Crop Management*. Iowa State University Extension and Outreach. Ames, Iowa. <https://crops.extension.iastate.edu/blog/mark-westgate-rebecca-vittetoe/addressing-edge-or-border-effect-corn-yields>
- White, T. and M. Licht. 2020. Corn edge effect on-farm project. *Integrated Crop Management*. Iowa State University Extension and Outreach. Ames, Iowa. <https://crops.extension.iastate.edu/blog/mark-licht-tyler-white/corn-edge-effect-farm-project>
- Wise, K. 2023. Fungicide Efficacy for Control of Corn Diseases. *Crop Protection Network*. CPN-2011-W. <https://cropprotectionnetwork.org/resources/publications/fungicide-efficacy-for-control-of-corn-diseases>
- Wise, K. 2023. Fungicide Efficacy for Control of Soybean Foliar Diseases. *Soybean Disease Management CPN-1019-W*. *Crop Protection Network*.
- Yadav A.N., D. Sharma, S. Gulati, S. Singh, R. Dey, K.K. Pal, R. Kaushik, and A.K. Saxena. 2015. Haloarchaea endowed with phosphorus solubilization attribute implicated in phosphorus cycle. *Sci Rep.* 5:12293. doi: 10.1038/srep12293.
- Yang, Y., X. Guo, H. Liu, G. Liu, W. Liu, B. Ming, R. Xie, K. Wang, P. Hou, A. Li. 2019. The effect of solar radiation change on the maize yield gap from the perspectives of dry matter accumulation and distribution. *J. of Integrative Agric.* 20:482-493. [https://doi.org/10.1016/S2095-3119\(20\)63581-X](https://doi.org/10.1016/S2095-3119(20)63581-X)
- Zhou, J., and I.E. Tzanetakis. 2013. Epidemiology of Soybean vein necrosis-associated virus. *Phytopathology* 103:966-971.
- Zhou, J., and I.E. Tzanetakis. 2019. Soybean vein necrosis virus: an emerging virus in North America. *Virus Genes* 10.1007/s11262-018-1618-4.
- Zhou, J., S.K. Kantartzi, R.H. Wen, M. Newman, M.R. Hajimorad, J.C. Rupe, and I.E. Tzanetakis. 2011. Molecular characterization of a new tospovirus infecting soybean. *Virus Genes* 43:289-295.
- Zukoff, S.N., K.R. Ostlie, B. Potter, L.N. Meihls, A.L. Zukoff, L. French. M.R. Ellersieck, B.W. French, and B.E. Hibbard. 2016. Multiple assays indicate varying levels of cross resistance in Cry3Bb1-selected field populations of the western corn rootworm to mCry3A, eCry3.1Ab, and Cry34/35Ab1. *J Econ Entomol* 109: 1387-1398.

# FOOTNOTES

<sup>1</sup>All Pioneer products are hybrids unless designated with AM1, AM, AMT, AMRW, AMX, AMXT, AML, and Q in which case they are brands.

# TRADEMARKS

**AM** - Optimum<sup>®</sup> AcreMax<sup>®</sup> Insect Protection system with YGCB, HX1, LL, RR2. Contains a single-bag integrated refuge solution for above-ground insects. In EPA-designated cotton growing counties, a 20% separate corn borer refuge must be planted with Optimum AcreMax products.

**AMXT** (Optimum<sup>®</sup> AcreMax<sup>®</sup> XTreme) - Contains a single-bag integrated refuge solution for above- and below-ground insects. The major component contains the Agrisure<sup>®</sup> RW trait, a Bt trait, and the Herculex<sup>®</sup> XTRA genes. In EPA-designated cotton growing counties, a 20% separate corn borer refuge must be planted with Optimum AcreMax XTreme products.

**AML** - Optimum<sup>®</sup> AcreMax<sup>®</sup> Leptra<sup>®</sup> products with AVBL, YGCB, HX1, LL, RR2. Contains a single-bag integrated refuge solution for above-ground insects. In EPA-designated cotton growing counties, a 20% separate corn borer refuge must be planted with Optimum AcreMax Leptra products.

**YGCB, HX1, LL, RR2** (Optimum<sup>®</sup> Intrasect<sup>®</sup>) - Contains a Bt trait and Herculex<sup>®</sup> I gene for resistance to corn borer. AVBL, YGCB, HX1, LL, RR2 (Optimum<sup>®</sup> Leptra<sup>®</sup>) - Contains the Agrisure Viptera<sup>®</sup> trait, the Bt trait, the Herculex<sup>®</sup> I gene, the LibertyLink<sup>®</sup> gene, and the Roundup Ready<sup>®</sup> Corn 2 trait.

ALWAYS READ AND FOLLOW PESTICIDE LABEL DIRECTIONS. Roundup Ready<sup>®</sup> crops contain genes that confer tolerance to glyphosate, the active ingredient in Roundup<sup>®</sup> brand agricultural herbicides. Roundup<sup>®</sup> brand agricultural herbicides will kill crops that are not tolerant to glyphosate.

**Q** (Qrome<sup>®</sup>) - Contains a single-bag integrated refuge solution for above- and below-ground insects. The major component contains the Agrisure<sup>®</sup> RW trait, the Bt trait, and the Herculex<sup>®</sup> XTRA genes. In EPA-designated cotton growing counties, a 20% separate corn borer refuge must be planted with Qrome products.

Components of LumiGEN<sup>®</sup> seed treatments for soybeans are applied at a Corteva Agriscience production facility or by an independent sales representative of Corteva Agriscience or its affiliates. Not all sales representatives offer treatment services, and costs and other charges may vary. See your sales representative for details. Seed applied technologies exclusive to Corteva Agriscience and its affiliates.

Enlist Duo<sup>®</sup> and Enlist One<sup>®</sup> herbicides are not registered for sale or use in all states or counties. Contact your state pesticide regulatory agency to determine if a product is registered for sale or use in your area. Enlist Duo and Enlist One are the only 2,4-D products authorized for use with Enlist crops. Consult Enlist herbicide labels for weed species controlled. Always read and follow label directions. Varieties with Enlist E3<sup>®</sup> technology (E3): The transgenic soybean event in Enlist E3<sup>®</sup> soybeans is jointly developed and owned by Corteva Agriscience and M.S. Technologies L.L.C.

Plenish<sup>®</sup> (P) high oleic soybeans have an enhanced oil profile and are produced and channeled under contract to specific grain markets. Growers should refer to the Pioneer Product Use Guide on [www.pioneer.com/us/stewardship](http://www.pioneer.com/us/stewardship) for more information.

Roundup Ready<sup>®</sup> is a registered trademarks used under license from Monsanto Company.

ILEVO<sup>®</sup> HL, Liberty<sup>®</sup>, LibertyLink<sup>®</sup> and the Water Droplet Design are registered trademarks of BASF.

Agrisure<sup>®</sup> and Agrisure Viptera<sup>®</sup> are registered trademarks of, and used under license from, a Syngenta Group Company. Agrisure<sup>®</sup> technology incorporated into these seeds is commercialized under a license from Syngenta Crop Protection AG.

Pioneer<sup>®</sup> brand products are provided subject to the terms and conditions of purchase which are part of the labeling and purchase documents.





